

THE VIRGINIA POWER EASEMENTS ARE NOT ADDRESSED.
 THE TELEPHONE EASEMENTS ARE NOT ADDRESSED.
 THE CABLE T.V. EASEMENTS ARE NOT ADDRESSED.
 NO FURTHER EASEMENT RESEARCH HAS BEEN PERFORMED
 TO UPDATE THESE EASEMENTS.

ZONING
 R-63

9' PRIVATE ALLEY
 IN COMMON

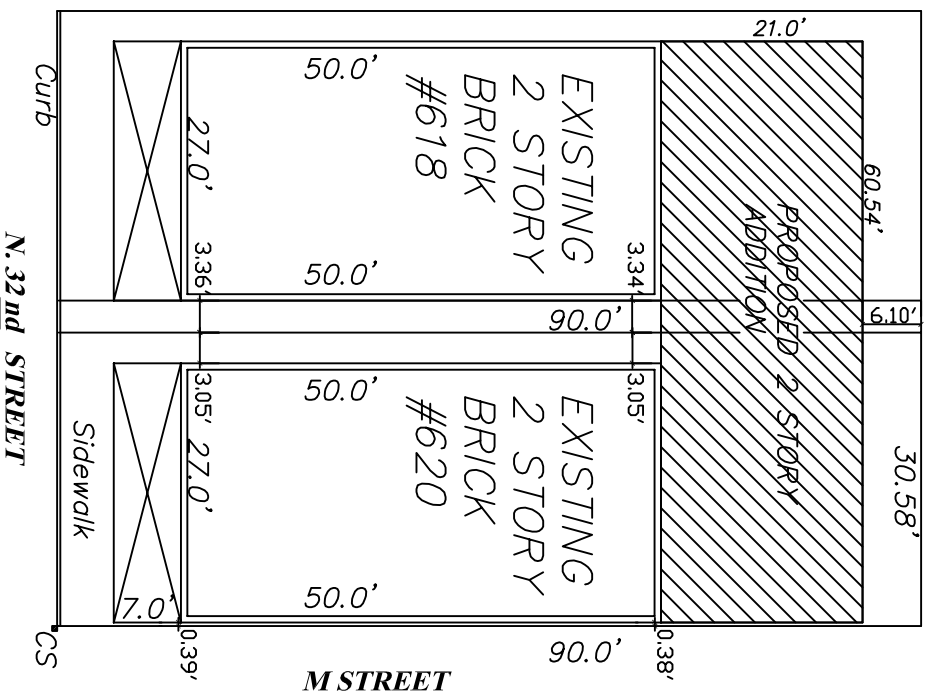

CONCIERGE

Construction Consulting, LLC
 PO Box 12534 | Richmond, VA 23241-0534
 TEL: 804.220.1895. hjohnson@cccllcva.com

PLAT SHOWING
 EXISTING PROPERTY ON
 618-620 N. 32ND STREET

DATE: JULY 28, 2015	RICHMOND, VA
SHEET 1 OF 1	SCALE: 1" = 20'
DRAWN BY: H. JOHNSON	CHECK BY: CWM

This plan and associated documents are the exclusive property of Concierge and may not be reproduced in whole or in part and shall not be used for any purpose without the written consent of Concierge. All rights reserved. Concierge, the Concierge logo, and/or construction related content are trademarks of Concierge.

DESIGNER

CSC, LLC
 CHUCK MCKINNEY-DESIGNER
 2400 MUNDY COURT
 RICHMOND, VA 23228
 804-261-0163 CELL 804-334-1167

BUILDING CODE

1. USE GROUP: MUR
2. CONSTRUCTION TYPE: IIB
3. APPLICABLE CODE: I.B.C. 2012
4. FIRE SUPPRESSION SYSTEM: NONE
5. ADDITION AREA: 2430 SQ. FT.
6. OCCUPANCY LOAD: 26
7. REQUIRED FIRE SEPARATIONS
 ONE HOUR BETWEEN TENANTS



PHOTO OF AFFECTED AREA

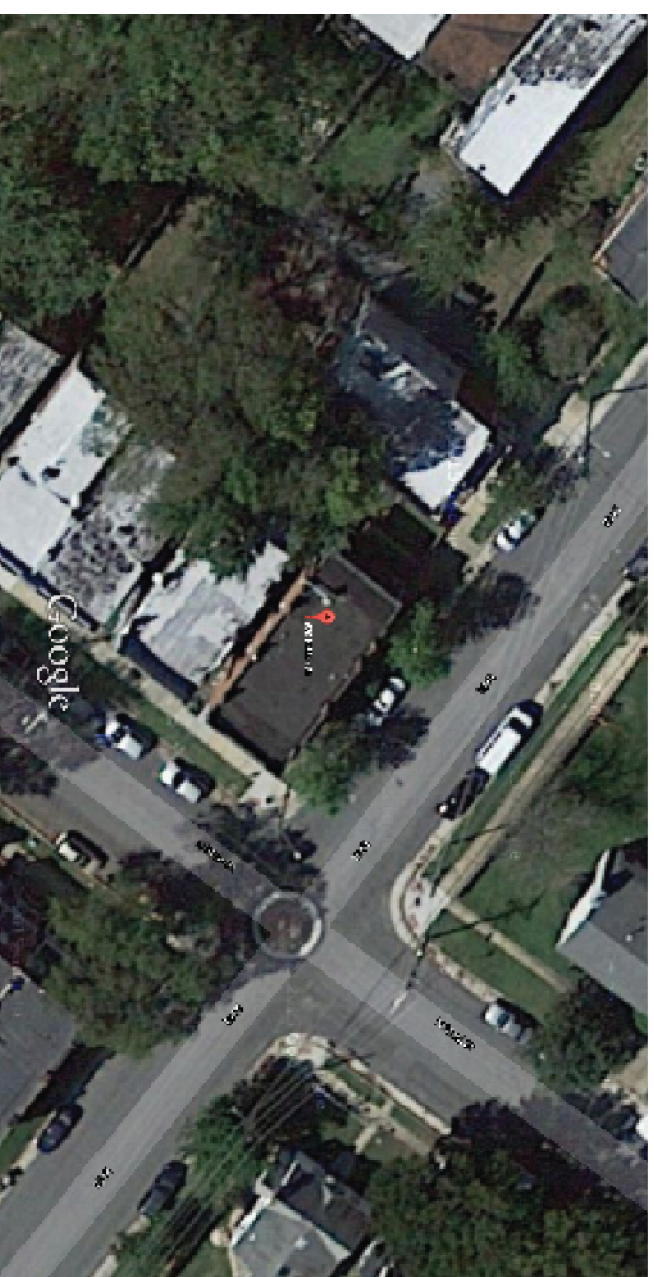

VICINITY MAP

ADULT HOME ADDITION	618-620 N. 32ND STREET	CONCIERGE LLC	7/28/2015	BP#	COVER PAGE	DRAWN BY: CWM
			1/4			SCALE: 1/8"=1'

BUILDING CODE

1. USE GROUP: MUR
2. CONSTRUCTION TYPE: IIB
3. APPLICABLE CODE: I.B.C. 2012
4. FIRE SUPPRESSION SYSTEM: NONE
5. ADDITION AREA: 2430 SQ. FT.
6. OCCUPANCY LOAD: 26
7. REQUIRED FIRE SEPARATIONS
ONE HOUR BETWEEN TENANTS

NOTES:

1. Bathroom sidewall grab bars shall be 42 inches min. in length, located 12 inches max. from the rear wall and extending 54 inches min. from the rear wall. A vertical grab bar 18 inches min. in length shall be mounted with the bottom of the bar located between 39 inches and 41 inches above the floor, and with the center line of the bar located between 39 and 41 inches from the rear wall.
2. Existing Ceiling is an existing wood frame 2x at 8'-6"+/-.
3. Walls to be 8'-6"+/-" 2x4 wood framing @16" O.C. with 5/8" Sheetrock.

DESIGNER

CSC, LLC
CHUCK MCKINNEY-DESIGNER
2400 MUNDY COURT
RICHMOND, VA 23228
804-261-0163 CELL 804-334-1167

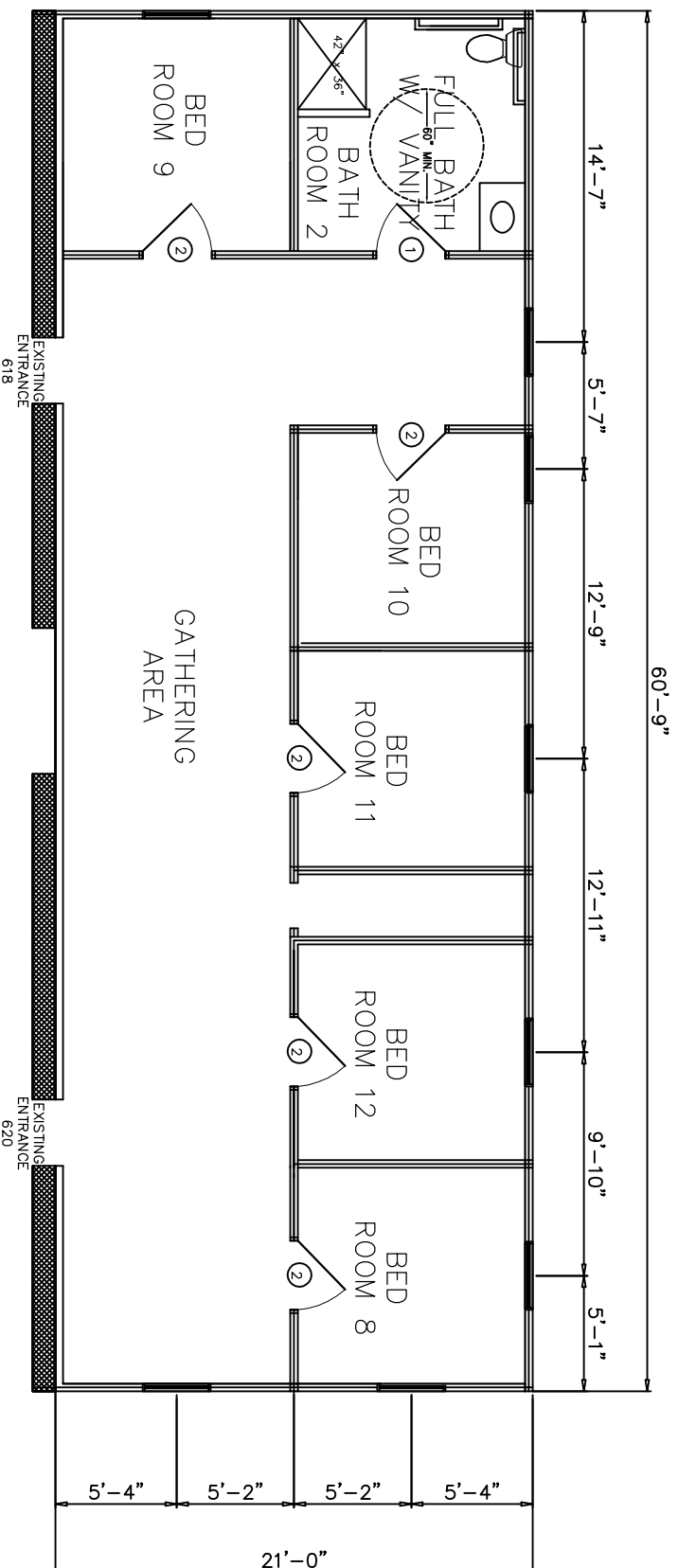
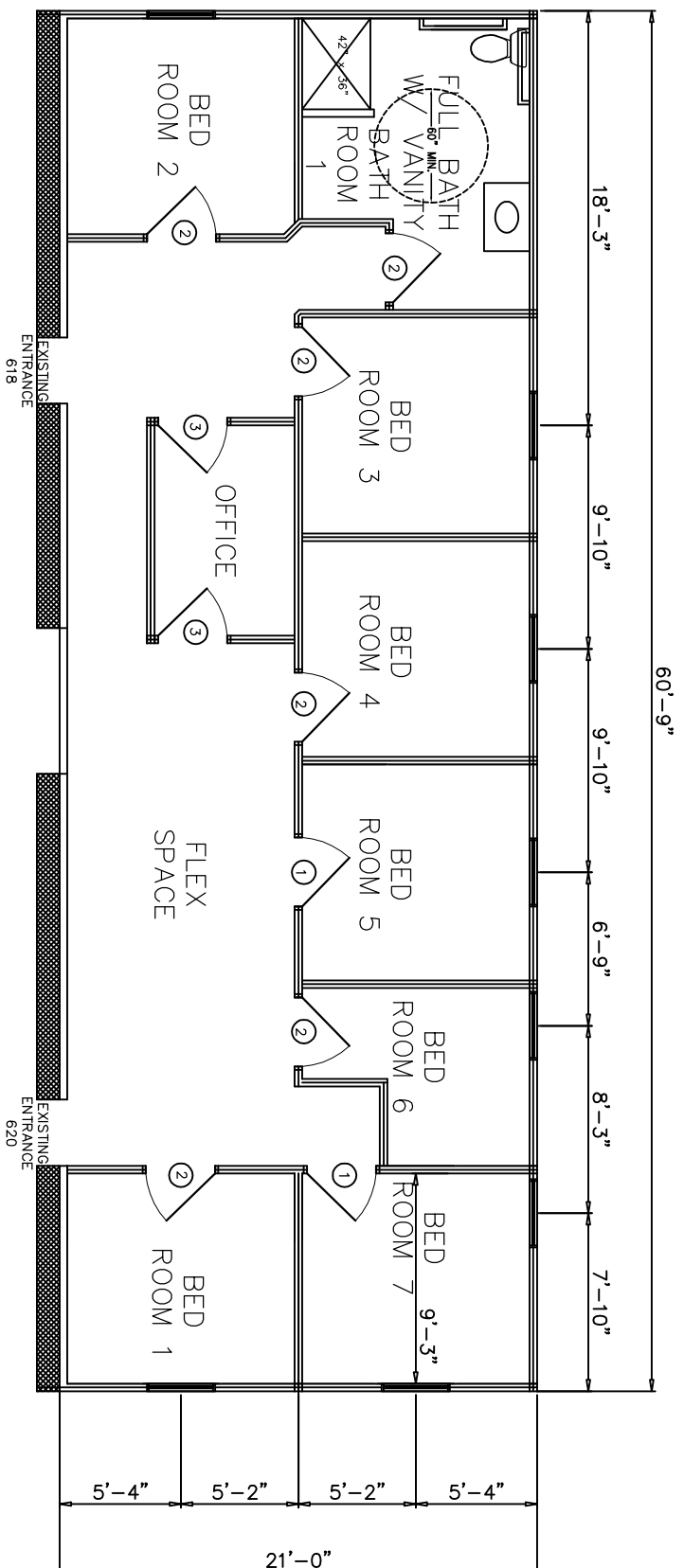
**DOOR SCHEDULE**

NUMBER	LOCK/HARDWARE TYPE	CLOSURE TYPE	DOOR SIZE	FIRE-RATING
1	SCHLAGE LEVER PRIVACY	TOP MOUNT	36"x80"	60 MINUTE
2	SCHLAGE LEVER PRIVACY	TOP MOUNT	36"x80"	60 MINUTE
3	SCHLAGE LEVER PRIVACY	TOP MOUNT	36"x80"	60 MINUTE

LEGEND

SYMBOL	DESCRIPTION
	EXISTING 2 HR RATED WALL
	1 HOUR FIRE RATING
	EXISTING EXTERIOR WALL
	36" WALL MAX. HEIGHT

BUILDING CODE

1. USE GROUP: MUR
2. CONSTRUCTION TYPE: IIB
3. APPLICABLE CODE: I.B.C. 2012
4. FIRE SUPPRESSION SYSTEM: NONE
5. ADDITION AREA: 2430 SQ. FT.
6. OCCUPANCY LOAD: 26
7. REQUIRED FIRE SEPARATIONS
ONE HOUR BETWEEN TENANTS

NOTES:

1. Bathroom sidewall grab bars shall be 42 inches min. in length, located 12 inches max. from the rear wall and extending 54 inches min. from the rear wall. A vertical grab bar 18 inches min. in length shall be mounted with the bottom of the bar located between 39 inches and 41 inches above the floor, and with the center line of the bar located between 39 and 41 inches from the rear wall.
2. Existing Ceiling is an existing wood frame 2x at 8'-6" +/-.
3. Walls to be 8'-6" +/- 2x4 wood framing @16" O.C. with 5/8" Sheetrock.

DESIGNER

CSC, LLC
CHUCK MCKINNEY-DESIGNER
2400 MUNDY COURT
RICHMOND, VA 23228
804-261-0163 CELL 804-334-1167

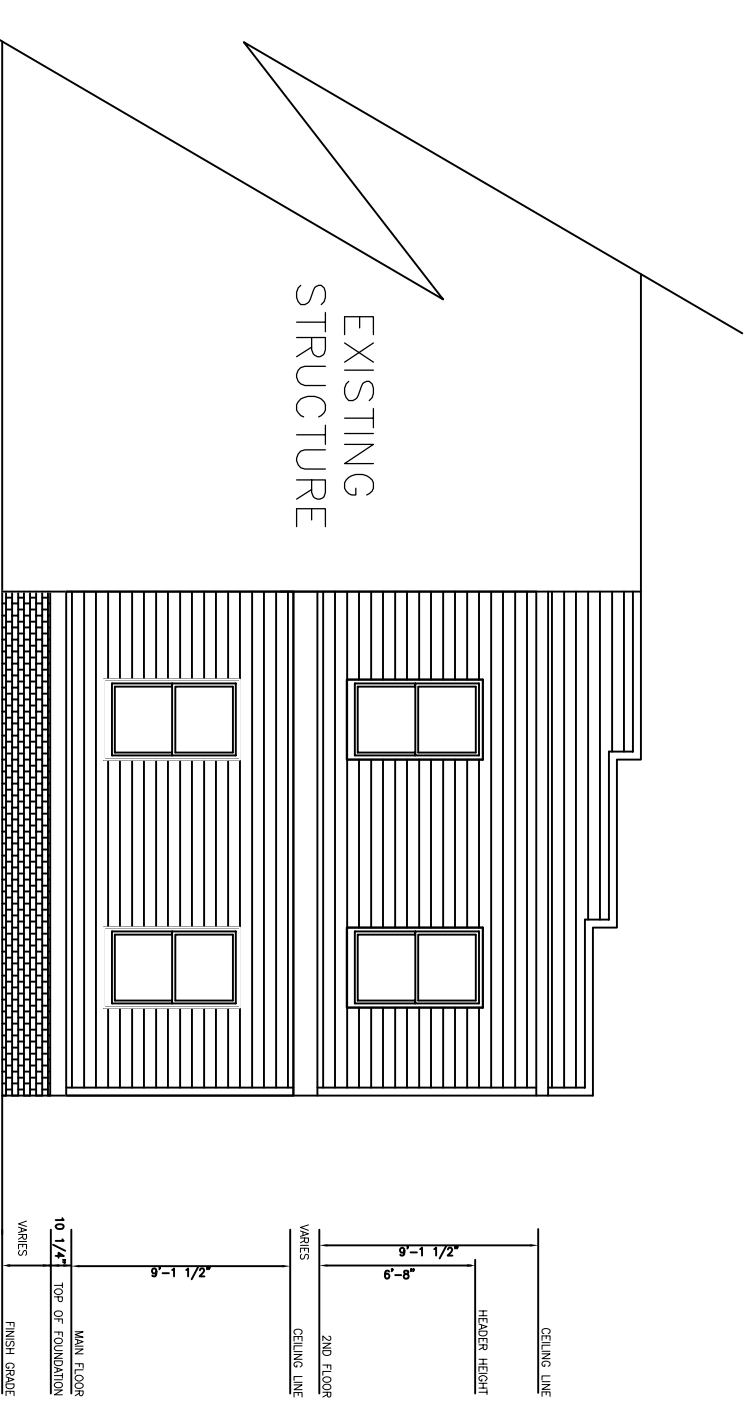

SIDE ELEVATION

1/8" = 1'-0"

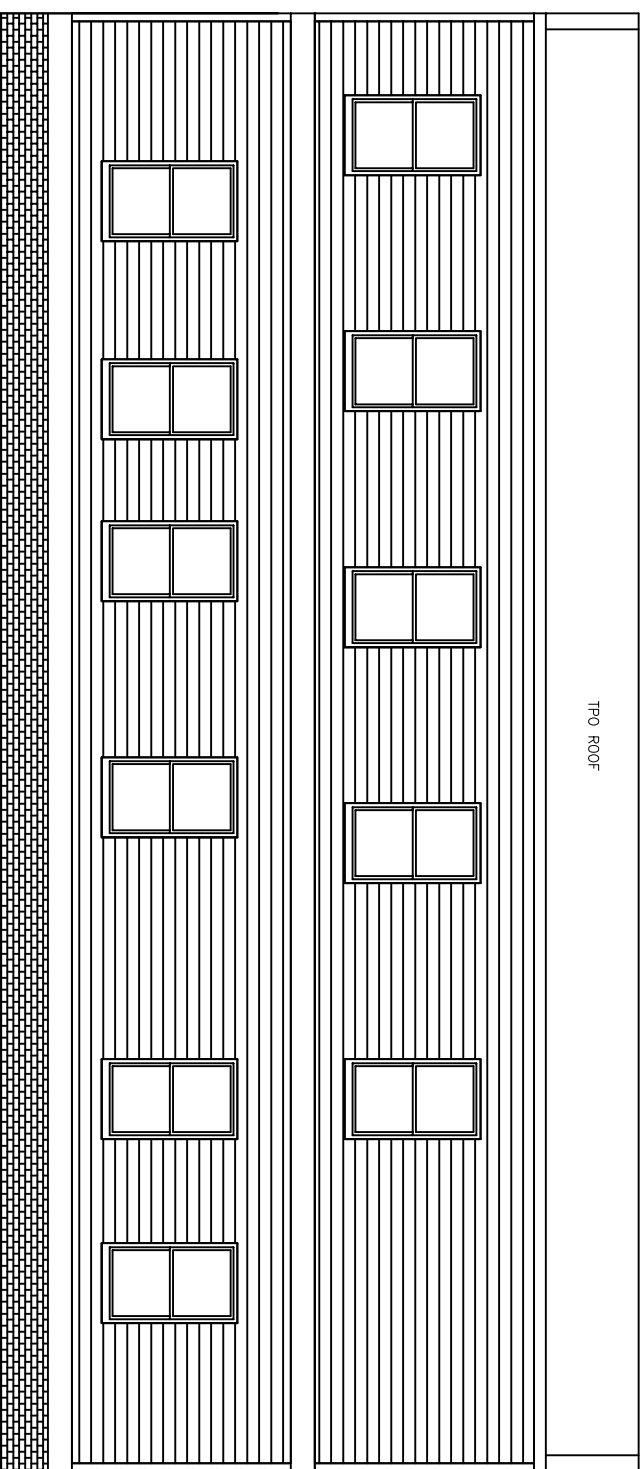

REAR ELEVATION

1/8" = 1'-0"

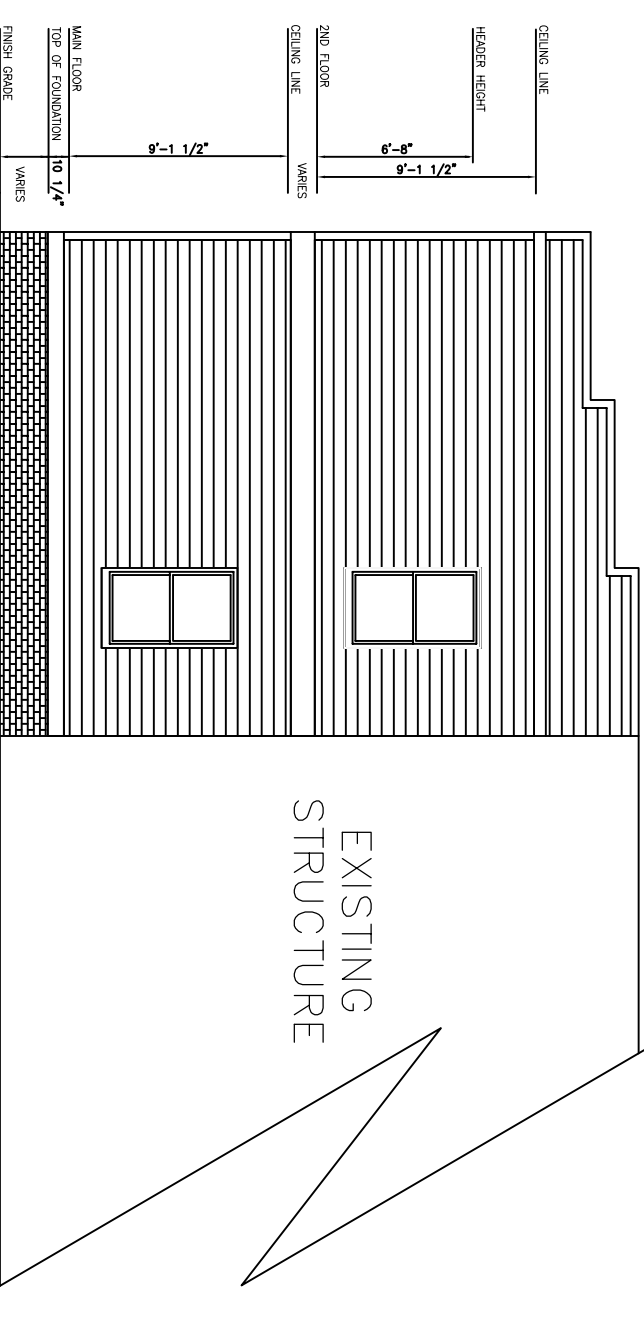

SIDE ELEVATION

1/8" = 1'-0"

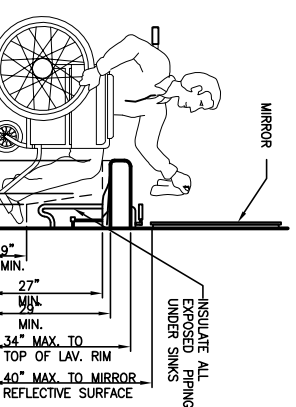

LAVATORY CLEARANCE SHIC
SCALE: 1/4" = 1'-0"

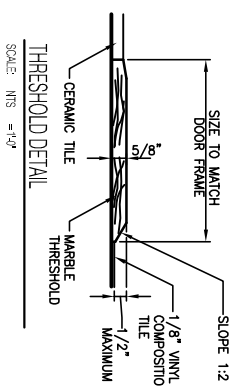

SCALE: INTS. = 1/4"

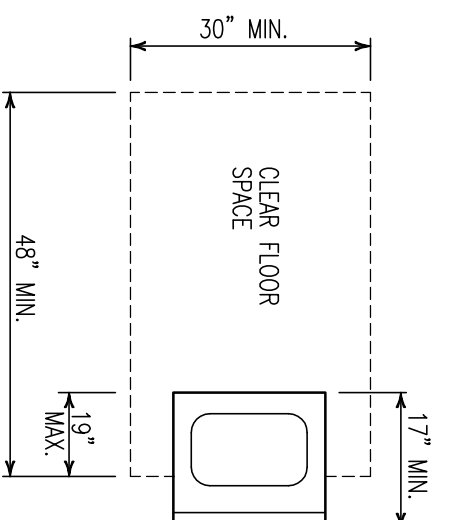

SCALE: 1/4" = 1'-0"

BUILDING CODE

1. USE GROUP: MUR
 2. CONSTRUCTION TYPE: IIB
 3. APPLICABLE CODE: I.B.C. 2012
 4. FIRE SUPPRESSION SYSTEM: NONE
 5. ADDITION AREA: 2430 SQ. FT.
 6. OCCUPANCY LOAD: 26
 7. REQUIRED FIRE SEPARATIONS
- ONE HOUR BETWEEN TENANTS**

NOTES:

1. Bathroom sidewall grab bars shall be 42 inches min. in length, located 12 inches max. from the rear wall and extending 54 inches min. from the rear wall. A vertical grab bar 18 inches min. in length shall be mounted with the bottom of the bar located between 39 inches and 41 inches above the floor, and with the center line of the bar located between 39 and 41 inches from the rear wall.
2. Existing Ceiling is an existing wood frame 2x at 8'-6" +/-.
3. Walls to be 8'-6" +/- 2x4 wood framing @16" O.C. with 5/8" Sheetrock.

DESIGNER

CSC, LLC
 CHUCK MCKINNEY-DESIGNER
 2400 MUNDY COURT
 RICHMOND, VA 23228
 804-261-0163 CELL 804-334-1167

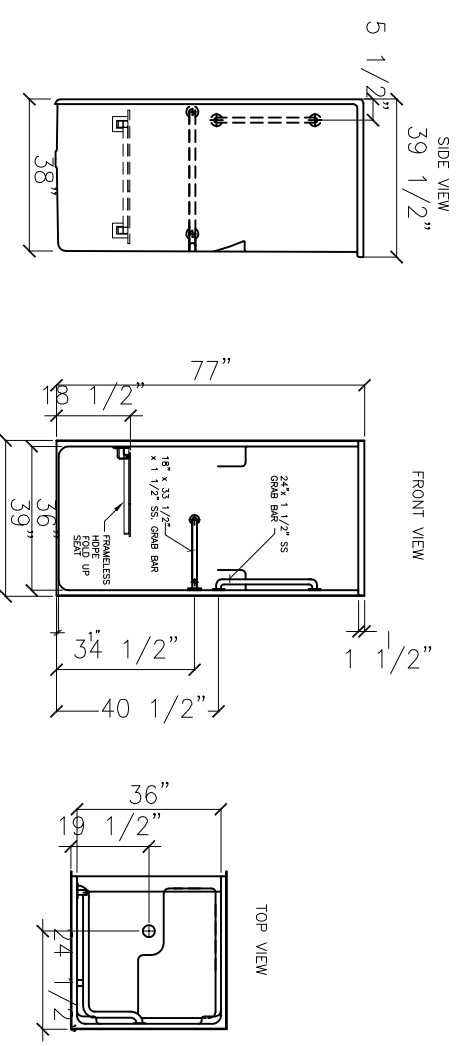

TYP. SHOWER ELEVATION
SCALE: 1/4" = 1'-0"

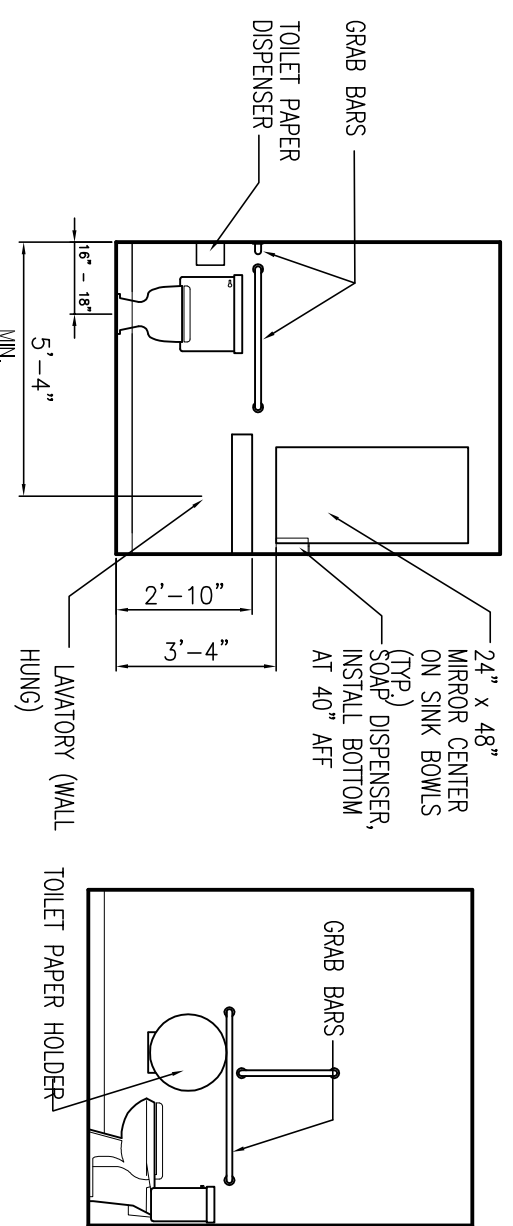

TYP. TOILET ROOM ELEVATION
SCALE: 1/4" = 1'-0"

2
A-2

TYP. SHOWER DETAIL
SCALE: 1/4" = 1'-0"

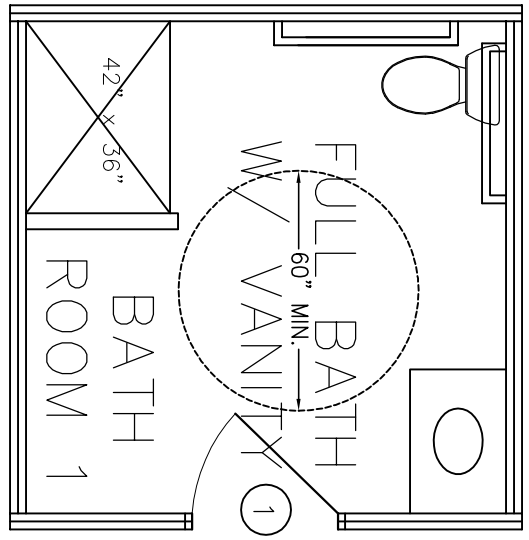

ADULT HOME ADDITION	618-620 N. 32ND STREET	COMMUNITY ALTERNATIVES CONSORTIUM	9/3/2015	4/4	FOR SUP REVIEW	DRAWN BY: CWM
					DETAIL SHEET	SCALE: 1/8" = 1'