



# Fire Training Facility

# WHY?

- Training Facility located in Henrico County (Sandston)
- Excessive cost for mandatory federal/state fire training
- Required fire recruit state certification training
- Mandatory Insurance Service Office facility training
- National Fire Protection Association 1710 Standard

# Current Fire Training Facility

- Sets on 4 acers and the Fire Training Facility is 12,133 square feet
- Training Facility 70 years old
- Burn Building is 40 years old
- Training Tower condemned in June 2018
- Structures Group Engineering Solutions performed Burn Building Status Report submitted in September 2021



5000 Beulah Rd  
Sandston, VA 23151

Treva Rd

Treva Rd

Treva Rd

Academy Ln

Thunderbolt St

Thunderbolt St

Thunderbolt St

Fire Academy Ln

Thunderbolt St

Beulah Rd

Beulah Rd

Richmond Fire Academy



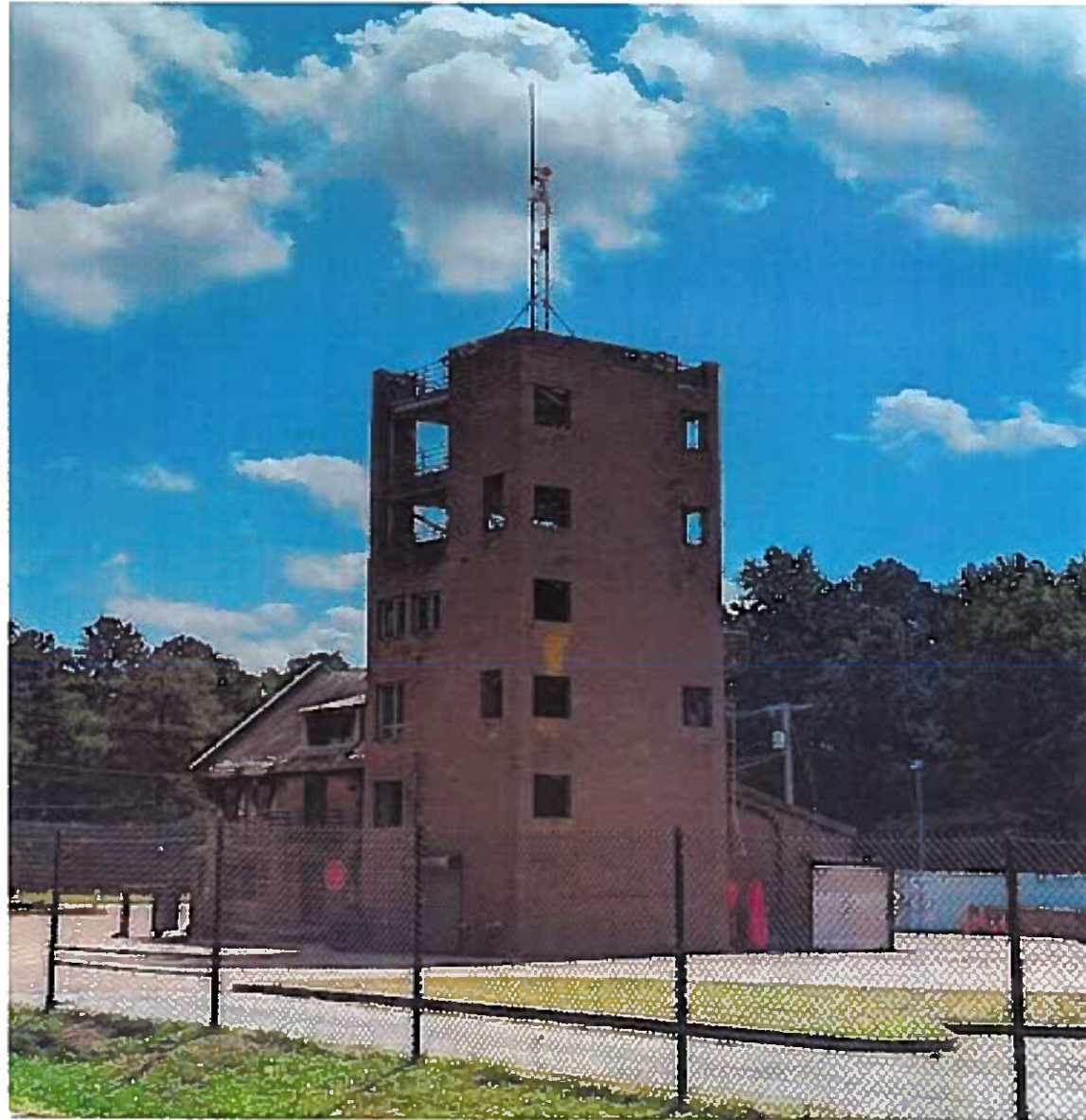

# Previous Fire Department Request?

- 2015 Capitol Improvement Project Budget Document
- 2020 Stimulus Package Funding
- 2021 Requested ARPA Funds
- 2021 Submitted grant application for new Fire Training Facility
- 2022 Facility Plan Document

**PROPRIETARY**

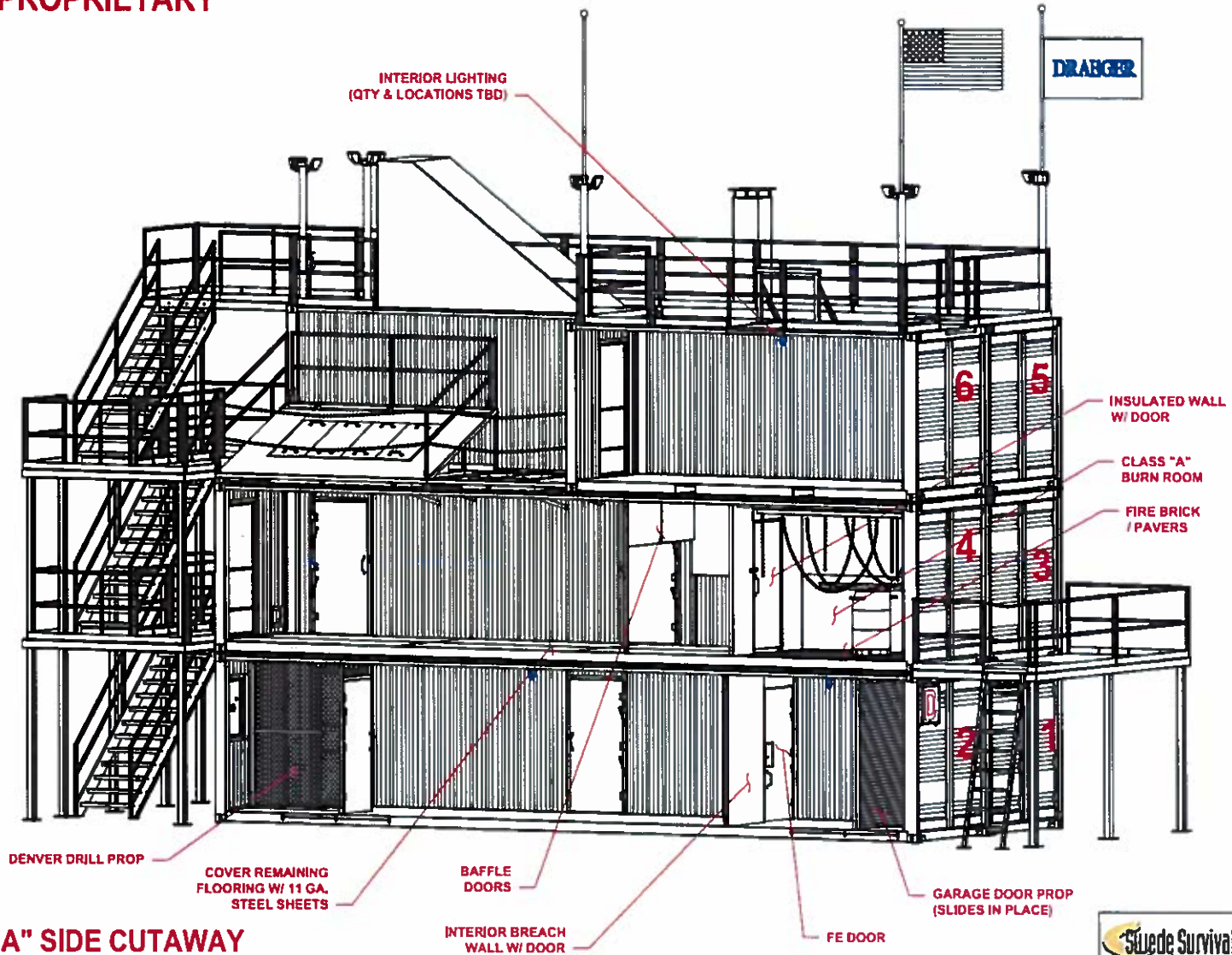



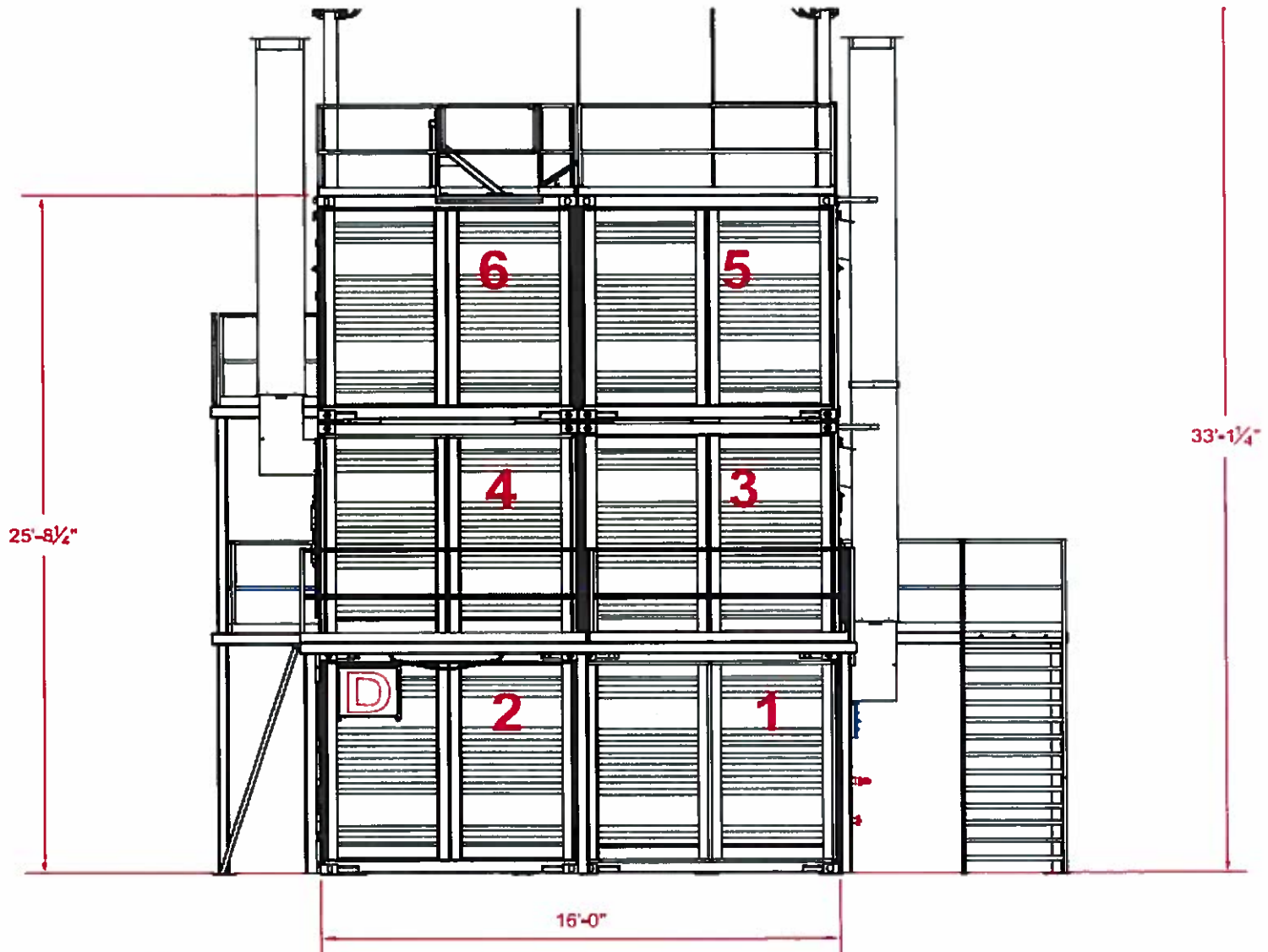

**"D" SIDE ELEVATION**



COUNTY OF  
SPECIAL MAINTENANCE

# Fire Department Steps

- Process started in December 2020
- Assessed property with Phillip Morris and the Virginia Port Authority
- Reviewed city owned properties
- Chose various sites to pursue based on acreage and location
- Results shared with the FD Executive Team December 2021
- Hickory Hill Community Center March 2022
- Walk through with Parks and Recreation Executive Team April 2022



4200 Deepwater Terminal Rd Deep

4200 Deepwater Terminal Rd







2728 Hermitage Rd,  
Richmond, VA 23220

2802

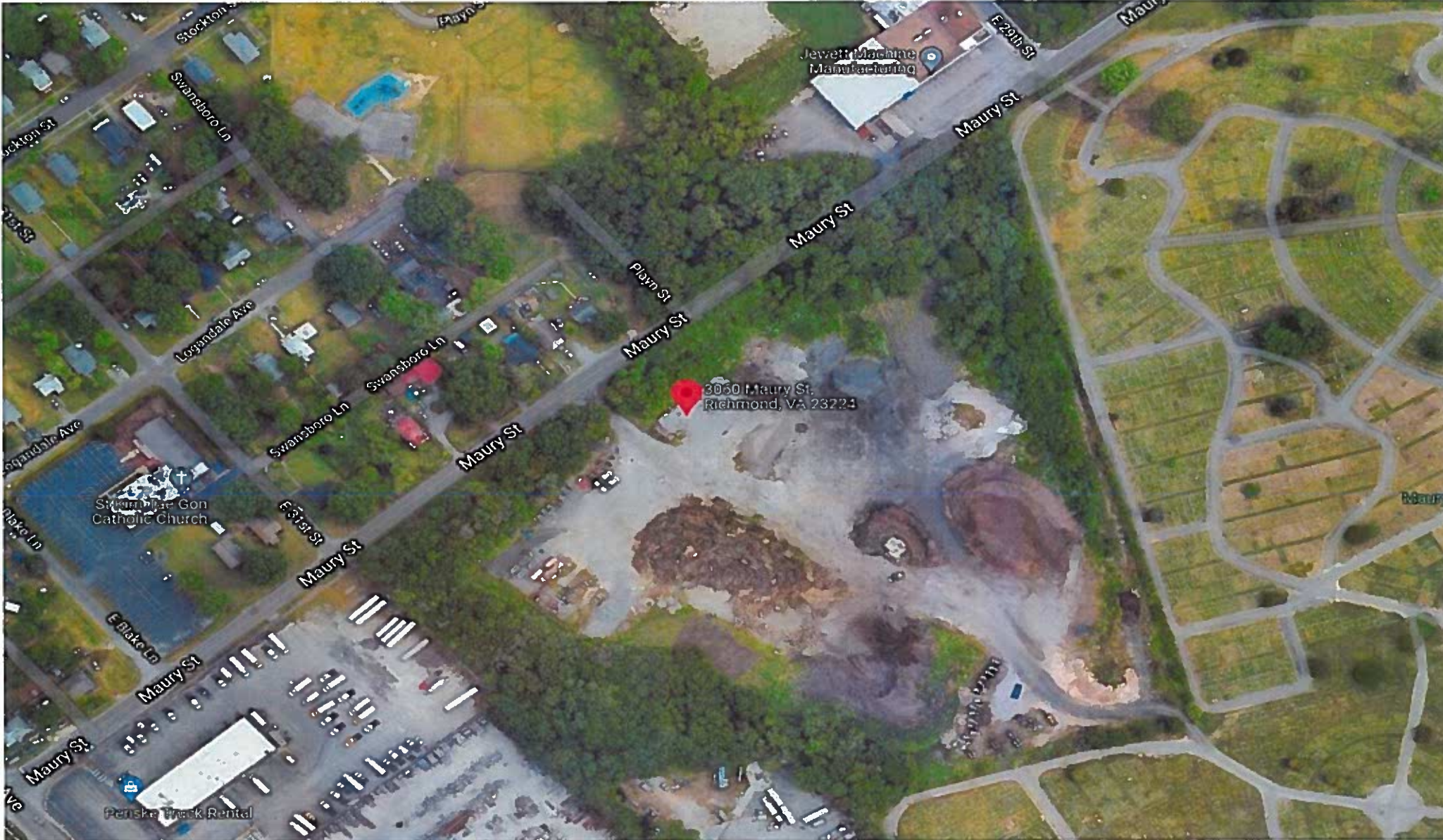



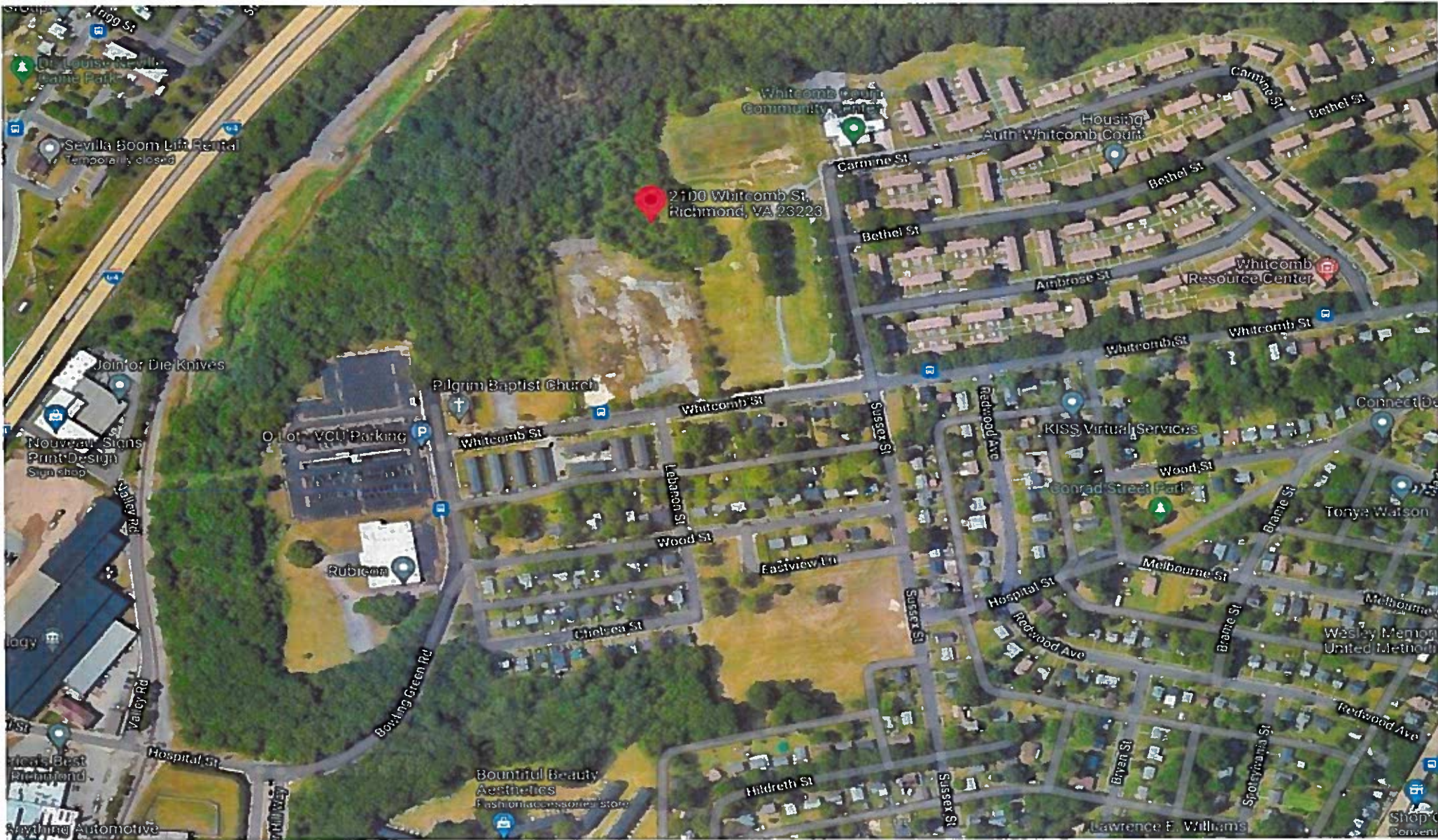

2100 Whitcomb St,  
Richmond, VA 23223

Whitcomb Court  
Community Center

Housing  
Auth Whitcomb Court

Whitcomb  
Resource Center

Pilgrim Baptist Church

O. Lot VCI Parking

Rubicon

KISS Virtual Services

Conrad Street Park

Bountiful Beauty  
Aesthetics  
Fashion accessories store

Wesley Memorial  
United Methodist

Lawrence E. Williams



Richmond City Office

Forest Lawn Rd

Forest Lawn Rd

Wm Rd

Northside Dog Park

Henderson Softball Complex

Project WARM Wood.Yard Temporarily Closed

Edge

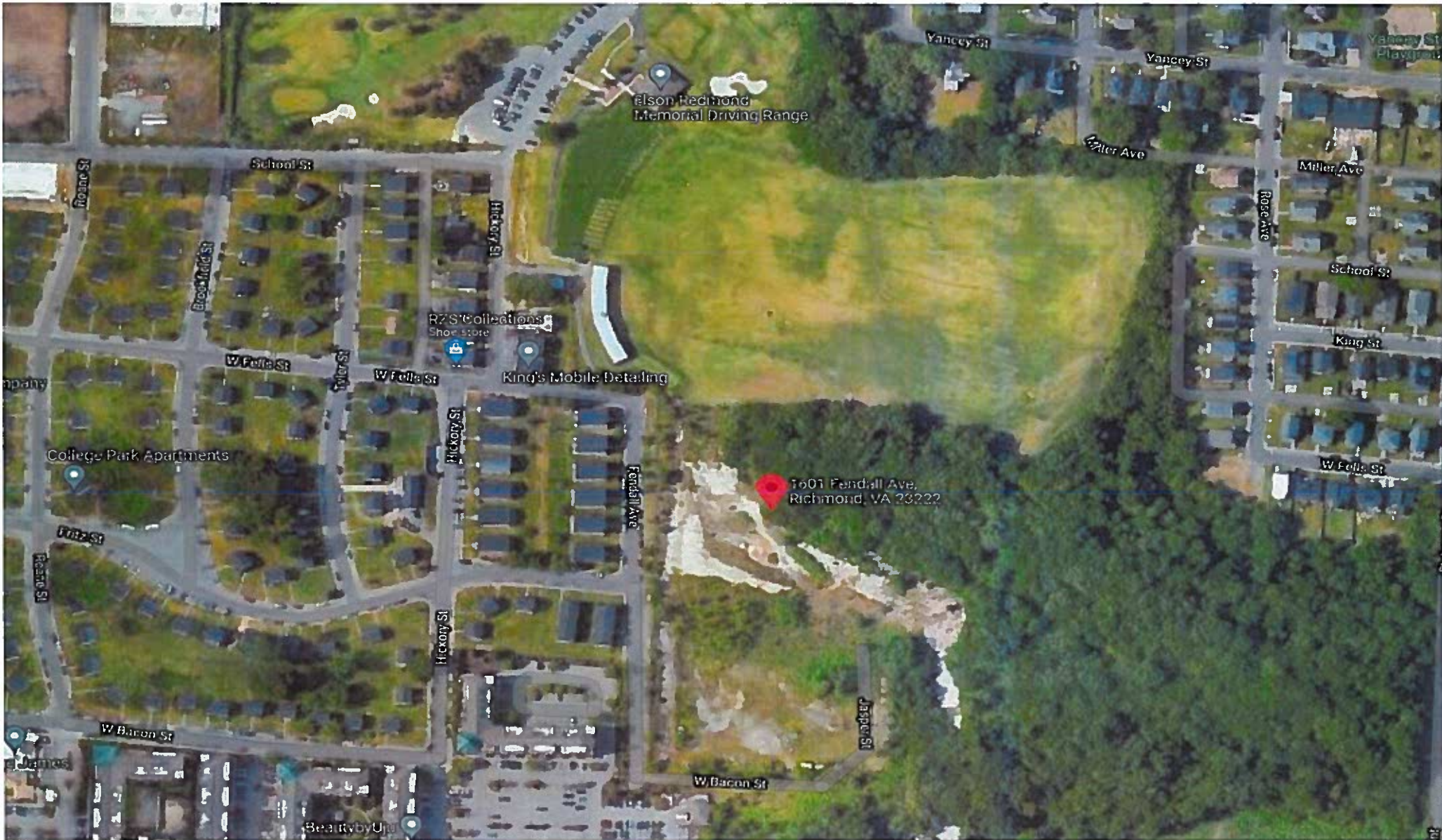



E Belt Blvd

Terminal Ave

Terminal Ave

Hickory Hill  
Community Center

E Belt Blvd

6401 E Belt Blvd,  
Richmond, VA 23234

Platinum Rd

161

# Community Concerns

- Historical Building
- Noise Level
- Environmental
- Community Outreach
- Hickory Hill Community Center Usage

# “Firefighter Noise Exposure During Training Activities and General Equipment Use”

- Thirteen of 15 types of equipment located on the fire engines emitted noise levels equal to or greater than 85 dBA
- Results indicated that the average noise exposure was 78 dBA during the training activities that lasted 70 min on average
- This study showed that the average noise levels experienced by firefighters was below generally accepted guidelines

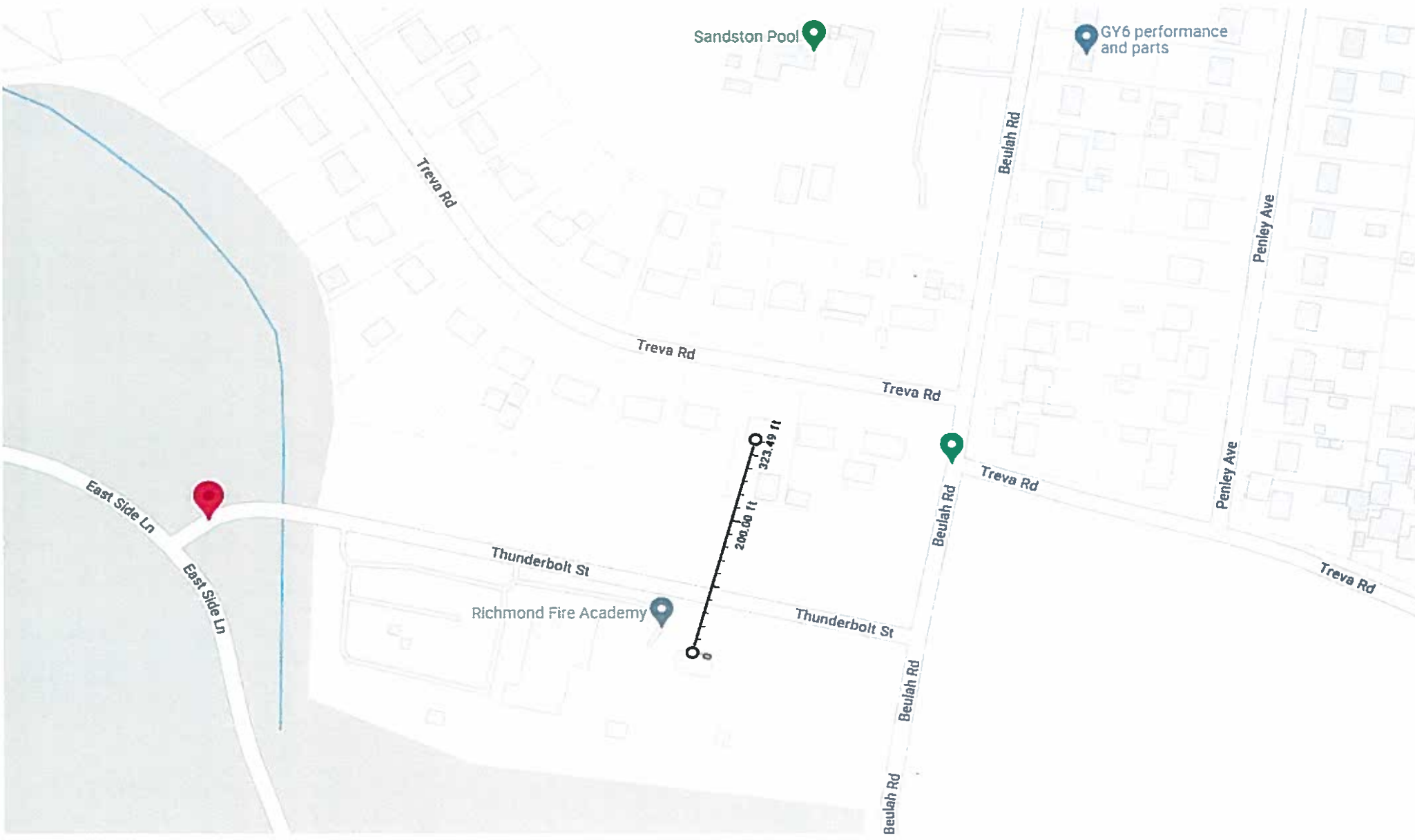

Sandston Pool

GY6 performance and parts



East Side Ln

East Side Ln

Treva Rd

Treva Rd

Treva Rd

Treva Rd

Treva Rd

Thunderbolt St

Thunderbolt St

Beulah Rd

Beulah Rd

Beulah Rd

Penley Ave

Penley Ave

# Environmental

- Required Fire Recruit Burn Days ( 6 days)
  - 55 Gallon Burn Barrel (Straw and wood)
- Fake Smoke Usage ( 12 days)
  - Smoke Candles (Gray smoke that burns for one to three minutes)
  - Froggy's Fog machine (Odorless, Non-irritating, Non-toxic, Non-flammable)
- No foam training allowed or conducted on-site
- No State Air Control permit required  
(Virginia Administrative Code 9VAC5-130-40)







# Fire Department Community Outreach

- Attended Southside community meeting December 1<sup>st</sup>
- Conducted community canvassing December and April
- Attended four 8th District meetings (signatures of support)
- Emailed all three community association president's (twice)
- Current community usage

# Neighborhood Canvassing

**FIRE TRAINING FACILITY**  
**3000 East Belt Boulevard**

**PROJECT SUMMARY:**  
The City of Richmond is constructing a new Fire Training Facility located at the corner located at 3000 East Belt Boulevard on the grounds of the Hickory Hill Community Center. This facility will provide essential training for recruits and current firefighters to deliver the best of the exceptional emergency services.

This project work consists of constructing a building for fire training purposes, a structure to park, recreational training, and landscaping. The location of the facility, shown in the rendering below, is located north of the existing Hickory Hill Community Center on the same City of Richmond property.

**Site Location**



**Site Rendering**



**Fire Training Facility – FAQ**

**What is the project timeline?**

- Acquire Permits and Approvals: November 2022 through March 2023
- Bid and Award Project: March 2023 through June 2023
- Commence Construction: June 2023
- Project Complete: June 2024

**Will this work impact traffic in the area?**  
The work is adjacent to East Belt Boulevard but no lane closures are anticipated. Construction traffic turning into the construction site will be negligible to existing traffic conditions.

**What training will occur at the facility?**  
The new Facility will serve as a training area for both new recruits and current emergency services staff. Recruit training typically lasts between 20 and 28 weeks and is divided into two phases, Emergency Medical Technician and Fire Training Certification. Current staff training typically takes 6 weeks per year.

**Will there be noise during training?**  
Most training will have minimal noise levels outside of the immediate training area and will not impact the surrounding neighborhood. Some of the fire recruit training ground activities that have minimal noise levels are:

- SCEA Training – Personal alert safety system devices may make sound similar to a smoke detector going off.
- Portable Entry Training – Repetitive metal on metal striking sounds.
- Ventilation Training – Gasoline powered equipment will be used.

**Will sirens or air horns be heard?**  
Firetrucks are not permitted to use sirens or air horns coming to or during training. The only time sirens may be heard is if the fire department is responding to emergency situations from the Fire Training Facility.

**Will training take place at night?**  
Some training activity will be conducted some nights and weekends under specific rules that minimize the level of noise coming from the Fire Training Facility.



**Will this work impact access to the Hickory Hill Community Center?**  
The construction will be within a fenced area on the property. Public access to the construction site will not be allowed due to safety considerations. Full use and access to the Community Center will remain unchanged during construction.

**When will this work be performed?**  
The City of Richmond's Department of Public Works anticipates that the work will mainly be performed between the hours of 8:00 a.m. to 5:00 p.m., Monday through Friday. Some isolated construction tasks may need to be performed at night or on weekends.

**Will the site be fenced?**  
The site will be fenced with an ornamental fencing system for facility security and community safety.

*Mayor Levar M. Stoney*

**IF YOU HAVE QUESTIONS, CONCERNS OR COMMENTS ABOUT THE PROJECT, PLEASE CONTACT:**  
Chief Melvin D. Carter  
Richmond Fire and Emergency Services  
204-668-8481  
Melvin.Carter@rfs.com

1/26/2023

# Hickory Hill Community Center Usage

- Hickory Hill Community Center
  - Letter of Support from Parks and Recreation
  - Current Memorandum of Understanding with Parks and Recreation
  - Emergency Medical Technician (March 6<sup>th</sup> – September 8<sup>th</sup>)
- Fire Training Facility
  - Monday thru Friday (8AM – 5 PM)
  - Few Saturdays



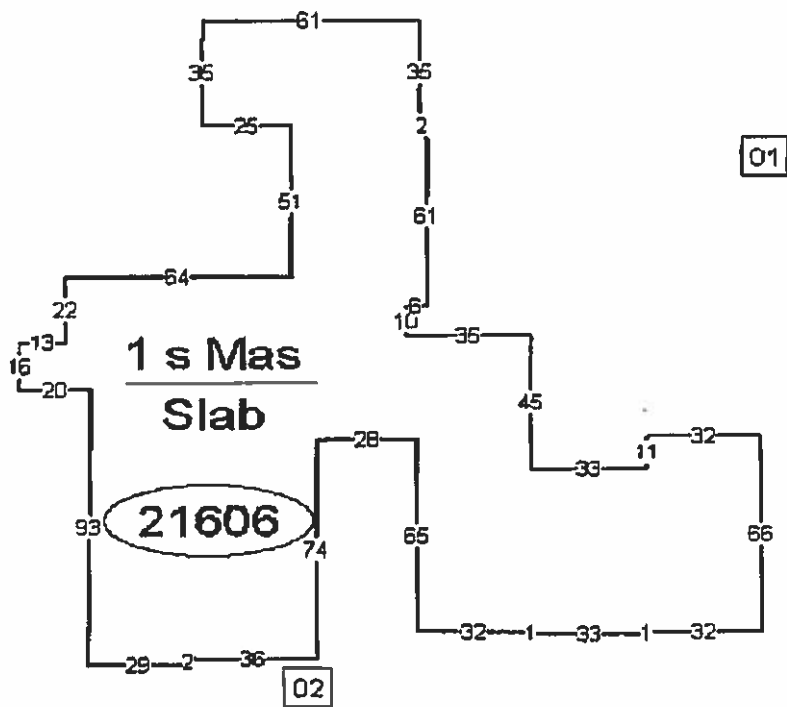

# WHY NOW

- To be good stewards of city resources
- To reduce cost long-term for required training
- To unite with community partners and create better youth outreach
- To meet the overall future fire department and city needs
- To create more diverse, equitable, and inclusive fire department





# Site Plan Rendering





# Building Rendering



# FIRE TRAINING FACILITY

## 3000 East Belt Boulevard

### PROJECT SUMMARY:

The City of Richmond is constructing a new Fire Training Facility located at Richmond located at 3000 East Belt Boulevard on the grounds of the Hickory Hill Community Center. The Facility will provide essential training to new recruits and current firefighters to deliver Richmond with exceptional emergency services.

The project work consists of constructing a building for fire training purposes, a concrete pad, ornamental fencing, and landscaping. The footprint of the Facility, shown in the rendering below, is located north of the existing Hickory Hill Community Center on the same City of Richmond property.

### Site Location



### Site Rendering

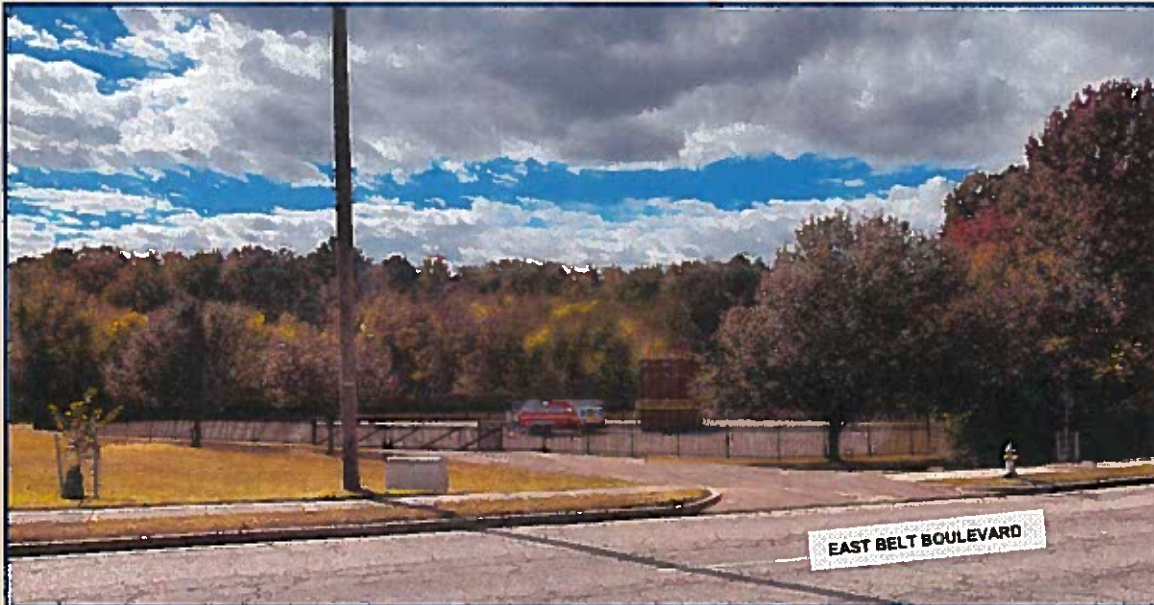

## Fire Training Facility – FAQ

**What is the project timeline?**

- Acquire Permits and Approvals: November 2022 through March 2023
- Bid and Award Project: March 2023 through June 2023
- Commence Construction: June 2023
- Project Completed: June 2024

**Will this work impact traffic in the area?**

The work is adjacent to East Belt Boulevard but no lane closures are anticipated. Construction traffic turning into the construction site will be negligible to existing traffic conditions.

**What training will occur at the facility?**

The new Facility will serve as a training area for both new recruits and current emergency services staff. Recruit training typically lasts between 20 and 26 weeks and is divided into two phases: Emergency Medical Technician and Fire Training Certification. Current staff training typically takes 8 weeks per year.

**Will there be noise during training?**

Most training will have minimal noise levels outside of the immediate training area and will not impact the surrounding neighborhood. Some of the fire recruit training ground activities that have minimal noise levels are:

- *SCBA Training* – Personal alert safety system devices may make sound similar to a smoke detector going off.
- *Forcible Entry Training* – Repetitive metal on metal striking sounds.
- *Ventilation Training* – Gasoline powered equipment will be used.

**Will sirens or air horns be heard?**

Firetrucks are not permitted to use sirens or air horns coming to or during training. The only time sirens may be heard is if the fire department is responding to emergency situations from the Fire Training Facility.

**Will training take place at night?**

Some training activity will be conducted some nights and weekends under specific rules that minimize the level of noise coming from the Fire Training Facility.

**Will this work impact access to the Hickory Hill Community Center?**

The construction will be within a fenced area on the property. Public access to the construction site will not be allowed due to safety considerations. Full use and access to the Community Center will remain unchanged during construction.

**When will this work be performed?**

The City of Richmond's Department of Public Works anticipates that the work will mainly be performed between the hours of 8:00 a.m. to 5:00 p.m., Monday through Friday. Some isolated construction tasks may need to be performed at night or on weekends.

**Will the site be fenced?**

The site will be fenced with an ornamental fencing system for facility security and community safety.

*Mayor Levar M. Stoney*

**IF YOU HAVE QUESTIONS, CONCERNS OR COMMENTS ABOUT THE PROJECT, PLEASE CONTACT:**

**Chief Melvin D. Carter**  
 Richmond Fire and Emergency Services  
 804-646-5451  
 Melvin.Carter@rva.com

