



Commission for Architectural Review Application for Certificate of Appropriateness

900 E. Broad Street, Room 510
Richmond, VA 23219 | (804)-646-6569
www.rva.gov/planning-development-review/commission-architectural-review

Property (location of work)

Address: 2720 E. Broad St.

Historic District: St. John's

Applicant Information Billing Contact

Name: Jennie & Walter Dotts

Email: jennie.dotts@longandfoster.com

Phone: 804.370.6565

Company: _____

Mailing Address: _____

Applicant Type: Owner Agent Lessee

Architect Contractor

Other (specify): _____

Owner Information Billing Contact

Same as Applicant

Name: _____

Email: walter@oldhouseauthority.com

Phone: _____

Company: _____

Mailing Address: 2720 E. Broad St.

Richmond 23223

****Owner must sign at the bottom of this page****

Project Information

Project Type: Alteration Demolition New Construction (Conceptual Review Required)

Project Description (attach additional sheets if needed):

A new front porch hand rail designed to complement the bracketed hood installed in 2009.

Acknowledgement of Responsibility

Compliance: If granted, you agree to comply with all conditions of the certificate of appropriateness (COA). Revisions to approved work require staff review and may require a new application and approval from the Commission of Architectural Review (CAR). Failure to comply with the conditions of the COA may result in project delays or legal action. The COA is valid for one (1) year and may be extended for an additional year, upon written request and payment of associated fee.

Requirements: A complete application includes all applicable information requested on checklists available on the CAR website to provide a complete and accurate description of existing and proposed conditions, as well as payments of the application fee. Applications proposing major new construction, including additions, should meet with staff to review the application and requirements prior to submitting an application. Owner contact information and signature is required. Late or incomplete applications will not be considered.

Zoning Requirements: Prior to Commission review, it is the responsibility of the applicant to determine if zoning approval is required an application materials should be prepared in compliance with zoning.

Signature of Owner  Date 2/21/24

02-19-2024



2731 WEST GRACE STREET
RICHMOND, VIRGINIA
888-501-9526

2720 East Grace St
Richmond, Virginia

SK-1

Copyright © 2024 The Yellow Room, Inc. All rights reserved.

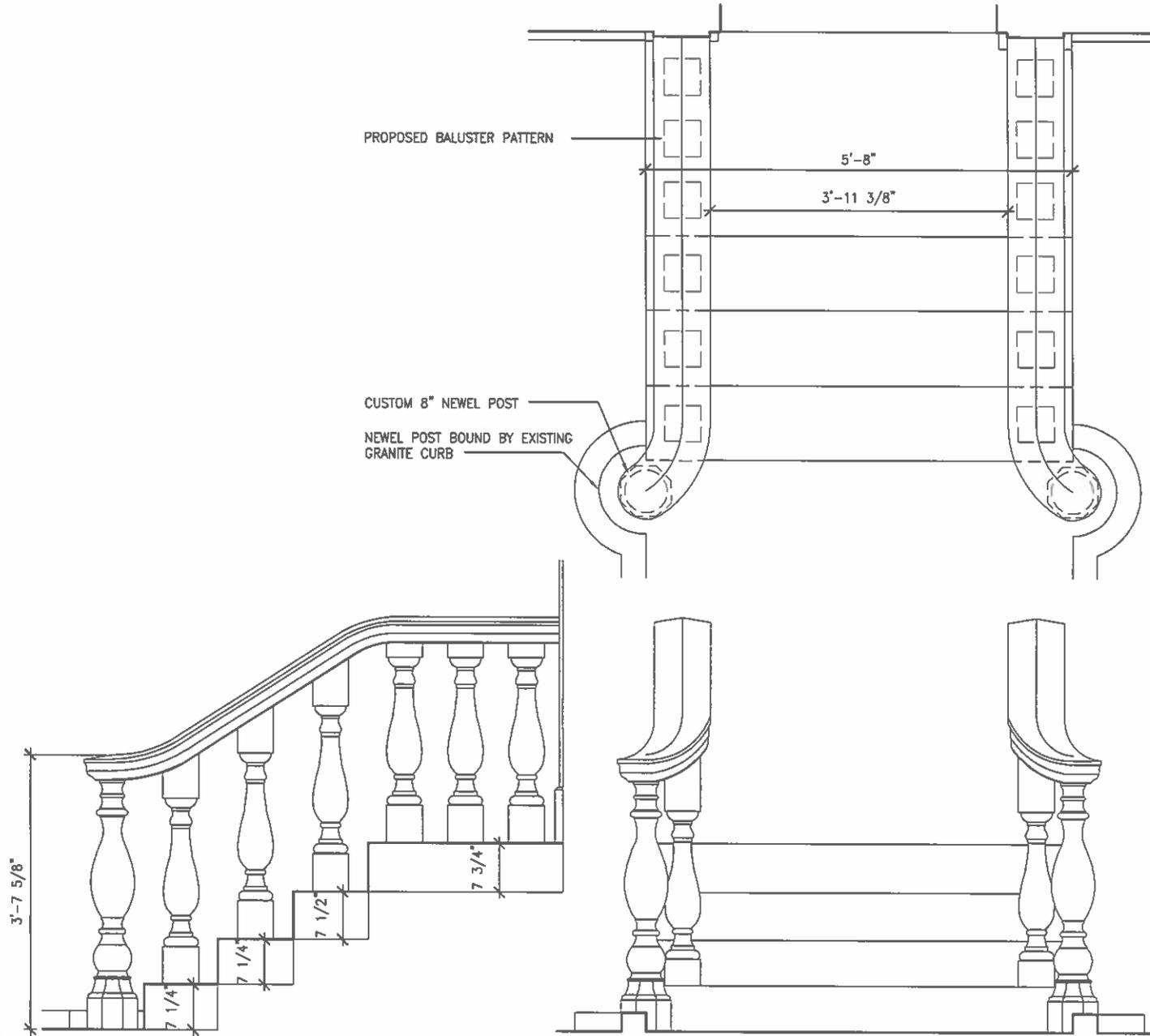

02-19-2024



2731 WEST GRACE STREET
RICHMOND, VIRGINIA
888-501-9526

2720 East Grace St
Richmond, Virginia

SK-2

Copyright © 2024 The Yellow Room, Inc. All rights reserved.

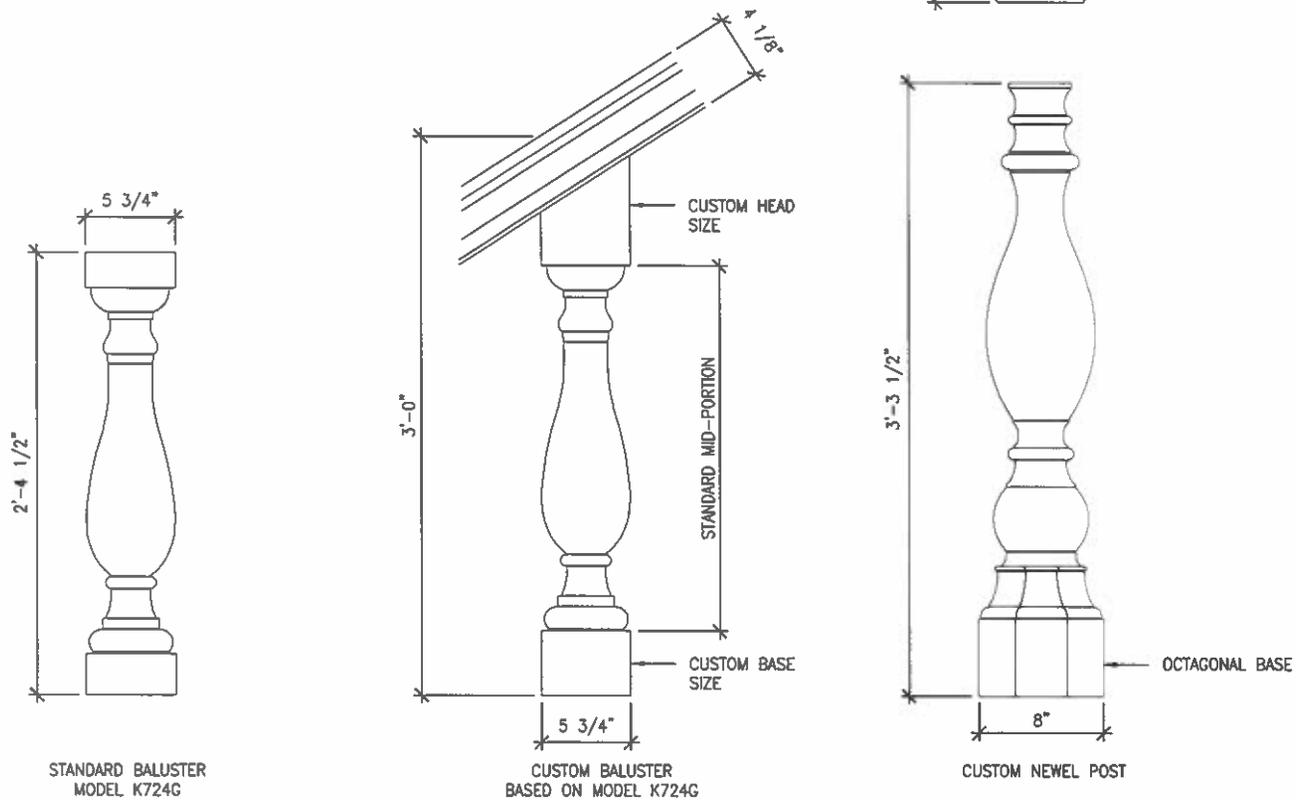

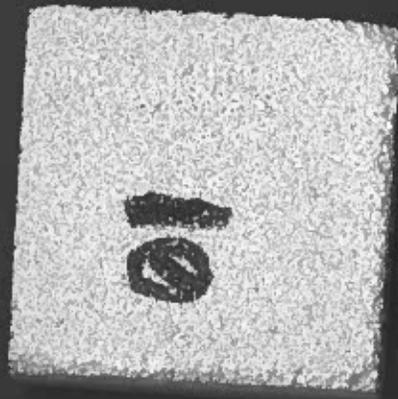







2720

