



COMMISSION OF ARCHITECTURAL REVIEW APPLICATION / CERTIFICATE OF APPROPRIATENESS

PROPERTY (Location of Work)

Address 1131 & 1137 West Grace Street

Historic District West Grace Street



PROPOSED ACTION

- Alteration (including paint colors)
- Addition
- Rehabilitation
- New Construction (Conceptual Review required)
- Demolition
- Conceptual Review
- Final Review

OWNER

Name Jeffrey W. Jacobs
 Company Saint John's United Church of Christ
 Mailing Address 503 Stuart Circle
Richmond, Virginia 23220
 Phone (804) 355-1115
 Email jwjacobs9@gmail.com
 Signature *Jeffrey W. Jacobs*
 Date October 31, 2017

APPLICANT (if other than owner)

Name Lory Markham
 Company Markham Planning
 Mailing Address 2314 West Main Street
Richmond, Virginia 23220
 Phone 804-248-2561
 Email lory@markhamplanning.com
 Signature _____
 Date _____

ACKNOWLEDGEMENT OF RESPONSIBILITY

Requirements: A complete application includes all applicable information requested on checklists to provide a complete and accurate description of existing and proposed conditions. Preliminary review meeting or site visit with staff may be necessary to process the application. Owner contact information and signature is required. Late or incomplete applications will not be considered.

Zoning Requirements: Prior to CAR review, it is the responsibility of the applicant to determine if zoning approval is required and application materials should be prepared in compliance with zoning.

Compliance: If granted, you agree to comply with all conditions of the COA. Revisions to approved work require staff review and may require a new application and CAR approval. Failure to comply with the COA may result in project delays or legal action. The COA is valid for one (1) year and may be extended for an additional year, upon written request.

(Space below for staff use only)

Application received:

Date/Time _____

Complete Yes No

By _____



CERTIFICATE OF APPROPRIATENESS

NEW CONSTRUCTION CHECKLIST

Well in advance of the COA application deadline contact staff to discuss your project, and if necessary, to make an appointment to meet with staff for a project consultation in the office or on site.

Complete all applicable sections and submit with the COA application form. Staff can assist you in determining what items are required for your scope of work. An incomplete application may cause delays in processing or may be deferred to the next agenda. Application materials must clearly represent current and proposed conditions. Refer to Standards for New Construction outlined in Section 30.930.7(c) of the City Code, as well as, the *Richmond Old and Historic Districts Handbook and Design Review Guidelines*.

PROPERTY ADDRESS: 1131 & 1137 West Grace Street

NEW BUILDING TYPE

- single-family residence
- multi-family residence
- commercial building
- mixed use building
- institutional building
- garage
- accessory structure
- other

DRAWINGS (refer to required drawing guidelines)

- floor plans
- elevations (all sides)
- roof plan
- list of windows and doors, including size, material, design
- context drawing showing adjacent buildings
- perspective
- site plan
- legal plat of survey

WRITTEN DESCRIPTION

- describe new structure including levels, foundation, siding, windows, doors, roof and details
- state how the *Richmond Old and Historic Districts Handbook and Design Review Guidelines* informed the proposed work, site specific pages and sections of the *Guidelines* that apply
- material description; attach specification sheets if necessary

PHOTOGRAPHS place on 8 ½ x 11 page, label photos with description and location (refer to photograph guidelines)

- site as seen from street, from front and corners, include neighboring properties



January 5, 2018

Ms. Marianne Pitts, Secretary
Commission of Architectural Review
Department of Planning & Development Review
900 East Broad Street, Suite 511
Richmond, VA 23219
Marianne.Pitts@richmondgov.com

RE: Applicant's Report for Final Certificate of Appropriateness for New Construction at 1131 & 1137 West Grace Street

Dear Ms. Pitts,

Please accept this letter as the Written Description for the application for a Final Certificate of Appropriateness for new construction of a multi-family building at 1131 & 1137 West Grace Street. We are seeking final approval of the elements of the project subject to review and as described in Section 30.930.7(c) of the City Code and the *Richmond Old and Historic Districts Handbook and Design Review Guidelines*. The siting, form, height, width, proportion and massing of the project was conceptually reviewed by the Commission at their September 26, 2017 meeting and again reviewed at the Commission's November 28, 2017 meeting. The Commission's comments at this meeting included:

- The Commission was generally supportive of scale and mass of the project, but requested that the step back for the 6th story be away from W Grace Street (5 stories on W Grace and 6 stories on the alley). *The plans have been revised to incorporate this comment.*
- A recommendation for a central entrance along W Grace Street. This was accommodated in the plans submitted for the November 28, 2017 meeting by the addition of a grand stair to the terrace level in the center of the building along W Grace Street. The addition of this stair also attempts to address staff's concern that the terrace level was not accessible from the ground and not at grade level. There was further discussion about the appropriateness of the stair and the raised terrace level at the November 28, 2017 meeting with most of the comments from the Commission reflective of this part of the design needing more detail and better graphics. *The building has been lowered farther below grade, lowering the terrace level closer to grade and the stair to access the terrace has been modified to provide a series of terrace levels. This design provides visual interest at the street, creates a connection between the building and the pedestrian realm and still serves to screen the interior parking located behind the stair and interior to the terrace level. Additional renderings have been included in this submission to better depict how the building will relate to its surroundings.*
- A recommendation that the materials be similar to the other multifamily buildings along this block of W Grace Street, which are predominantly brick buildings. *The proposal uses red brick*

and limestone colored brick or synthetic stone similar to the materials used on the building to the east.

- A recommendation that the massing of the building should respond to the entrance whether it is at the corner or the center of the building. *The main entrance to the residential lobby has been shifted to N Lombardy and the building materials and shape accentuate this entrance as shown on the plans.*

Site

The proposal is located on two parcels totaling 0.826 acres at the corner of North Lombardy Street and West Grace Street. The property is currently improved with a paved surface parking area. The proposed development consists of new construction of a multi-family building with up to 105 dwelling units. The proposal will include approximately 130 parking spaces in two levels of parking accessed from the existing alley, one level of which will be located below grade. The level of parking located above grade will have occupied space fronting on West Grace Street and will not be visible to the pedestrian. An additional 16 surface parking spaces will be located behind the building and also accessed from the existing alley. There will be five-stories of residential units above the parking levels. Two outdoor courtyards will be located on top of the parking level with units fronting onto them. The courtyard facing West Grace Street will be accessible to the street with a grand stair.

Zoning Regulations

The property is currently located in the R-73 Multi-Family Residential Zoning District. The proposal is a by-right development and will comply with all the requirements of the R-73 district. This district allows for high density multifamily uses and limited commercial uses, including offices, hospitals and day nurseries. The R-73 district requires front, side and rear yards with a depth of 15 feet for multifamily uses. There is a 2.0 floor area ratio requirement and a 0.25 useable open space requirement that will be met. The maximum height allowed by the R-73 district is 150 feet with further restrictions based on incline planes drawn from the centerline of the adjacent streets. The proposal does not take advantage of the full height permitted by the existing zoning district.

Richmond Old and Historic Districts Handbook and Design Review Guidelines

In addition to being located in the R-73 Multi-Family Residential Zoning District, the site is also located in the West Grace Street Old & Historic District overlay. The standards for approval of the proposal under this district are outlined in Section 30.930.7(c) of the City Code and the *Richmond Old and Historic Districts Handbook and Design Review Guidelines*. The table below outlines how the proposal complies with the applicable standards.

Category	Standard	1131 W Grace St
Section 30.930.7(c) of the City Code		
	<p>The commission of architectural review shall approve new construction which it deems to be compatible with the design, scale, materials, color, height, setback, and other pertinent features of the old and historic district in which it is located.</p>	<p>This project received conceptual review of the siting, form, height, width, proportion and massing of the proposed multi-family building at the Commission's September 26, 2017 meeting and again reviewed the proposal on November 28, 2017. This application has responded to the comments from the Commission at that meeting and seeks conceptual review of the details of the proposal; including the porch and porch details, windows, doors, colors and materials. These details are shown on the plans and are consistent with the West Grace Street and Monument Avenue Historic Districts.</p>
Richmond Old and Historic Districts Handbook and Design Review Guidelines		
<i>Siting</i>		
pg. 50	<p>The context for review begins with the building and its immediate neighbors, but also expands to include the surrounding buildings on the block face and across the street (within the historic district).</p>	<p>The subject property is surrounded by a myriad of building forms, height and types. The proposal's form and height is consistent with the proposed building type and takes cues from the surrounding properties to the south, east and north. The subject property is located at a prominent corner in the West Grace Street Old & Historic District where the District begins to transition from larger scale multifamily and institutional type buildings to the smaller scale single- and two-family houses to the west. This transition is clearly demarcated by the large stone columns just to the west of the subject property indicating that the scale and form appropriate for the site should come more from the properties to the east and south.</p>
	<p>New commercial infill construction should respect the prevailing front and side yard development patterns of the surrounding block. The minimum setbacks evident in most districts reinforce the traditional street wall. In cases where the adjoining buildings have different setbacks, the setback for the new building should be based on the historical pattern for the block.</p>	<p>The proposed front setback is 18'10" and the side yard setbacks are 15'. These setbacks exceed the zoning requirements and the side yard setbacks in the surrounding block are consistent with the district.</p>

	New commercial buildings should face the most prominent street bordering the site.	The proposed building predominantly fronts on West Grace with units and a terraced courtyard. The lobby and main entrance are located on North Lombardy at the prominent corner of West Grace and Lombardy.
	For large-scale commercial parking, parking within the building is strongly encouraged. If a building includes parking within it, vehicle entry doors should be located on non-primary elevations.	The majority of the parking to serve the building is located within a two-level parking structure accessed from the alley. There will be no parking visible from West Grace Street and the vehicle entry doors will be on the alley elevation.
<i>Form</i>		
pg. 50	New commercial construction should use a building form compatible with that found elsewhere in the immediate area. Building form refers to the specific combination of massing, size, symmetry, proportions, projections and roof shapes that lend identity to a building. Building form is greatly influenced by the architectural style of a given structure.	The proposed H-shape configuration of the building creates courtyards on the north and south. These courtyards serve as open space for the residents and reduce the width of the building at the street front. This technique is typical of many historic Fan apartment buildings, fitting into the context of the area. The proposed flat roof is also typical of surrounding buildings and buildings found in the district.
	New commercial construction should maintain the existing human scale of nearby historic commercial buildings in the district. New commercial construction should incorporate human-scale elements at the pedestrian level.	The proposal will have a terraced courtyard and apartments that front on to West Grace Street providing active uses along the sidewalk to engage the pedestrian. A meandering stair will front West Grace Street that will allow pedestrians to access the terraced courtyard from the street. Doors, windows and entrances will face the street providing human-scale elements at the pedestrian level. All the vehicular entrances, trash and other non human-scale elements will be accessed from the alley out of sight from the pedestrians along West Grace and Lombardy.
<i>Height, Width, Proportion & Massing</i>		

<p>pg. 51</p>	<p>New commercial construction should respect the typical height of surrounding buildings, both residential and commercial.</p>	<p>The proposal is consistent in height with the adjacent church building and lower than the church steeple. The height steps down towards West Grace Street to provide a lower presence along the street. Additionally, this site is on a prominent corner in the West Grace Street Old & Historic District and is adjacent to the Monument Avenue Historic District. There are several examples of taller buildings on corners located in these districts, particularly on North Lombardy and in the next block on North Allen, where there are six-story buildings on both Grace and Monument. Diagonally across from this subject property is the Stuart Court Apartment building, which is eleven stories in height. At six-stories with one level of underground parking, the proposal will respect the height of these surrounding buildings and its prominent location on the corner of West Grace and North Lombardy.</p>
	<p>New commercial construction should respect the vertical orientation typical of commercial buildings in Richmond’s historic districts. New designs that call for wide massing should look to the project’s local district for precedent. When designing new commercial buildings that occupy more than one third of a block face, the design should still employ bays as an organizational device, but the new building should read as a single piece of architecture.</p>	<p>The proposed structure occupies less than a quarter of the block face and employs an H-shaped with two bays and a recess in the middle to organize the building and provide varying setbacks and interest to the property. Only the H-shape will be five-stories with the back portion being six-stories.</p>
	<p>The cornice height should be compatible with that of adjacent historic buildings.</p>	<p>The proposed cornice height will be compatible with the adjacent historic church to the south and significantly lower than the historic multi-family building to the west.</p>
<p><i>Materials & Colors</i></p>		
	<p>Materials used in new construction should be visually compatible with original materials used throughout the surrounding neighborhood.</p>	<p>The predominant material proposed for the building is a red tone brick with a buff synthetic stone material around the base of the building. Red brick is found throughout the West Grace Historic District and is one of the original materials used here.</p>
	<p>Paint colors used should be similar to the historically appropriate colors already found in the immediate neighborhood and throughout the larger district.</p>	<p>The exterior of the building will not be painted.</p>

	Vinyl, asphalt, and aluminum siding are not permitted for use in City Old and Historic Districts. Other synthetic siding materials with a smooth, untextured finish may be allowed in limited cases, but approval by the Commission is always required.	No vinyl, asphalt or aluminum siding is proposed.
	Rooftop mechanical equipment should be located as discretely as possible to limit visibility. In addition, appropriate screening should be provided to conceal equipment from view. When rooftop railings are required for seating areas or for safe access to mechanical equipment, the railings should be as unobtrusive as possible, in order to minimize their appearance and visual impact on the surrounding district.	The rooftop mechanical equipment will not be visible from the street and there will be no visual impact on the surrounding neighborhood. There is a parapet wall proposed that will screen the equipment. No rooftop railings are proposed.
	For larger-scale projects that involve communal garbage collection (such as dumpsters or other large collection device), these garbage receptacles should be located away from the primary elevation or elevations of the building (preferably to the rear) and screened from view	The trash and dumpsters will be enclosed and will be accessed from the alley. They will not be visible from West Grace Street or North Lombardy.
<i>Doors & Windows</i>		
pg. 53	The size, proportion and spacing patterns of door and window openings on a new addition should follow patterns established by the original structure. Windows on most commercial properties throughout Old and Historic Districts have a vertical orientation. Wide, horizontal so-called "picture windows" on new additions are strongly discouraged.	The proposed windows are all vertical in orientation. There are no wide, picture windows proposed. The windows are primarily double-hung sash windows.
	The size, proportion, and spacing patterns of door and window openings on free standing new construction should be compatible with patterns established within the district.	The size, proportion, and spacing pattern of the door and window openings are residential in character and are compatible with the adjacent multi-family buildings in the district.
	With larger buildings, applicants are encouraged to develop multiple entry points (doors), in keeping with historic precedent for the building type in question. Single entry points - such as a single garage entrance accompanied by single pedestrian entrances are not in keeping with historic precedent, which demonstrates that most large buildings had multiple pedestrian entry points.	The main entrance to the building is located on North Lombardy with units and amenity space fronting on West Grace. The units fronting on West Grace will have patio areas and porches fronting on the street. There will also be a terraced entry from West Grace up to the courtyard in the center of the building. This will provide for multiple entry points to the building.
<i>Porches & Porch Details</i>		

pg. 46	New porch railing designs, compatible with the overall design of the building, will also be considered.	The building will have railings on the porches, balconies and courtyard level. These railings will be consistent with the design of the building.
	Faux balconies (flat, applied constructs with no depth) are discouraged. Small projecting balconies are acceptable.	The proposed balconies in the center of the building all project from the building and have depth into the courtyards below. The porches fronting on West Grace will be three levels above grade and will have substantial columns similar to the porches found on other multi-family buildings in the block.

Thank you for your consideration of this application. Please feel free to contact me at lory@markhamplanning.com or (804) 248-2561 if you have any questions or require additional materials to process the application.

Very Truly Yours,



Lory Markham

Enclosures

West Grace Street
(71' ± R/W)

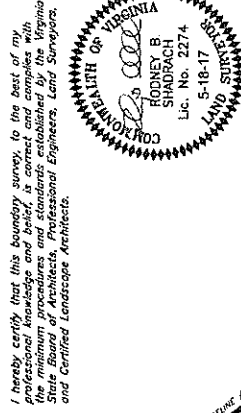

I hereby certify that this boundary survey, to the best of my professional knowledge and belief, is correct and complies with the minimum procedures and standards established by the Virginia State Board of Architects, Professional Engineers, Land Surveyors, and Certified Landscape Architects.

LEGAL REFERENCES:

- PARCEL 1:**
Trustees of Saint John's
United Church of Christ
Deed Book 6408, Page 205
Tax Parcel W000-0614/001
#1137 West Grace Street
- PARCEL 2:**
Trustees of Saint John's
United Church of Christ
Tax Parcel W000-0614/002
#1137 West Grace Street

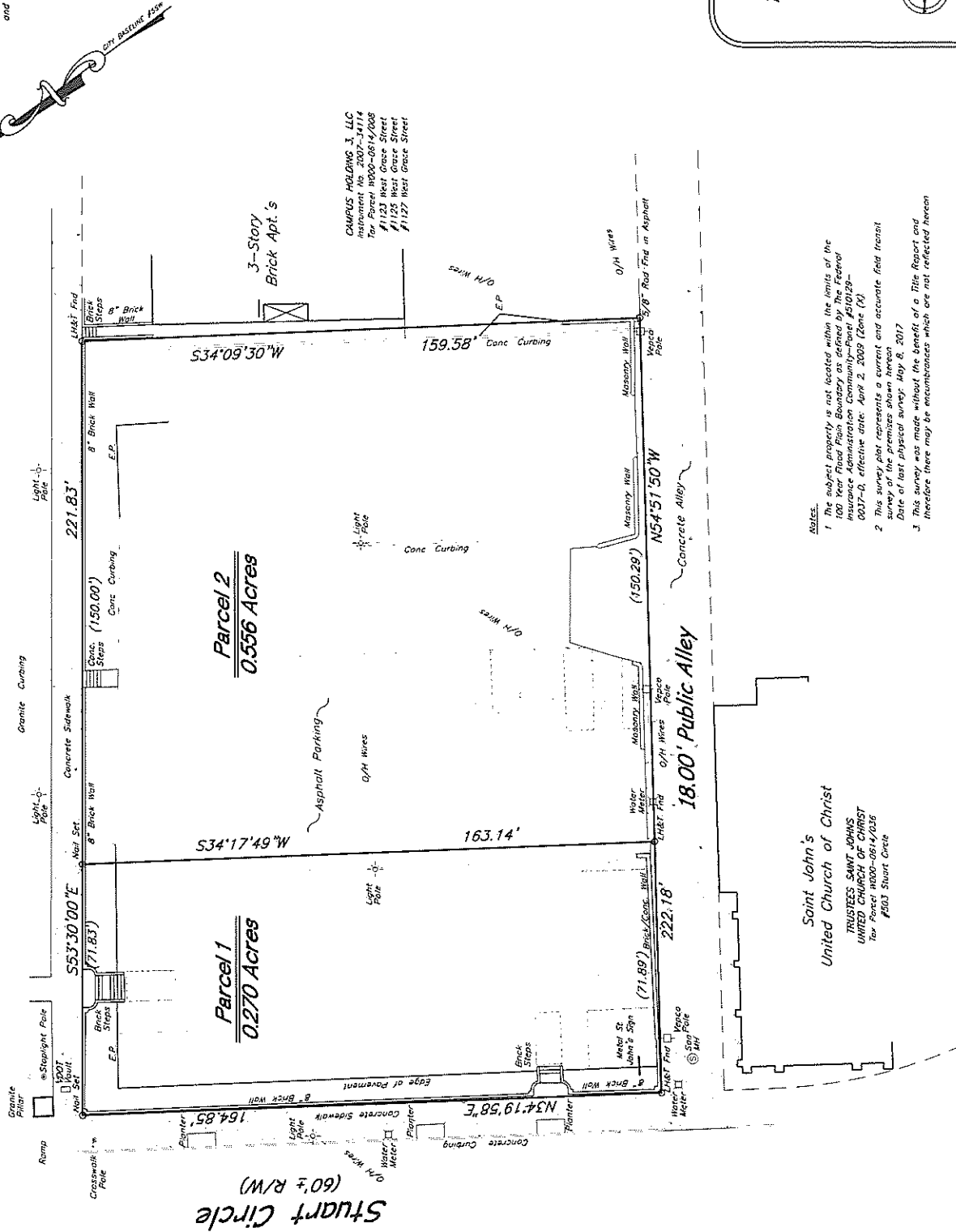

BOUNDARY SURVEY
SHOWING EXISTING IMPROVEMENTS
TO #1137 & #1137 W. GRACE STREET
CITY OF RICHMOND, VIRGINIA
DATE: MAY 18, 2017



Shadrach & Associates LLC
LAND SURVEYING
430 Samba Blvd., Suite 10-B • Richmond, Virginia 23226
Phone: (804)375-3300 • Email: rod@shadrachsurvey.com

- NOTES:**
- 1 The subject property is not located within the limits of the 100 Year Flood Plain Boundary as defined by the Federal Insurance Administration Community Plan #10019-0027-0, effective date: April 2, 2009 (2nd Ed.).
 - 2 This survey plat represents a current and accurate field transit survey of the premises shown herein.
 - 3 This survey was made without the benefit of a Title Report and therefore there may be encumbrances which are not reflected herein.

Saint John's
United Church of Christ
TRUSTEES SAINT JOHN'S
UNITED CHURCH OF CHRIST
Tax Parcel W000-0614/001
#104 Stuart Circle



Subject property view from West Grace Street



Subject property view from North Lombardy Street



Adjacent property to the west across North Lombardy



Adjacent property to the west across North Lombardy Street



Adjacent property to the south across the alley, view from Stuart Circle



Adjacent property to the south across the alley, view from North Lombardy Street



Adjacent property to the north across West Grace Street



Adjacent property to the east







Grace & Lombardy
 1137 W. Grace St. Richmond VA

project #: 17.28
 date: 1/8/18

NEIGHBORHOOD CONTEXT

A.1

313 N. Adams Street
 Richmond, VA 23220
 1 804.644.4761
 1 804.644.4763

walterPARKS
 ARCHITECT

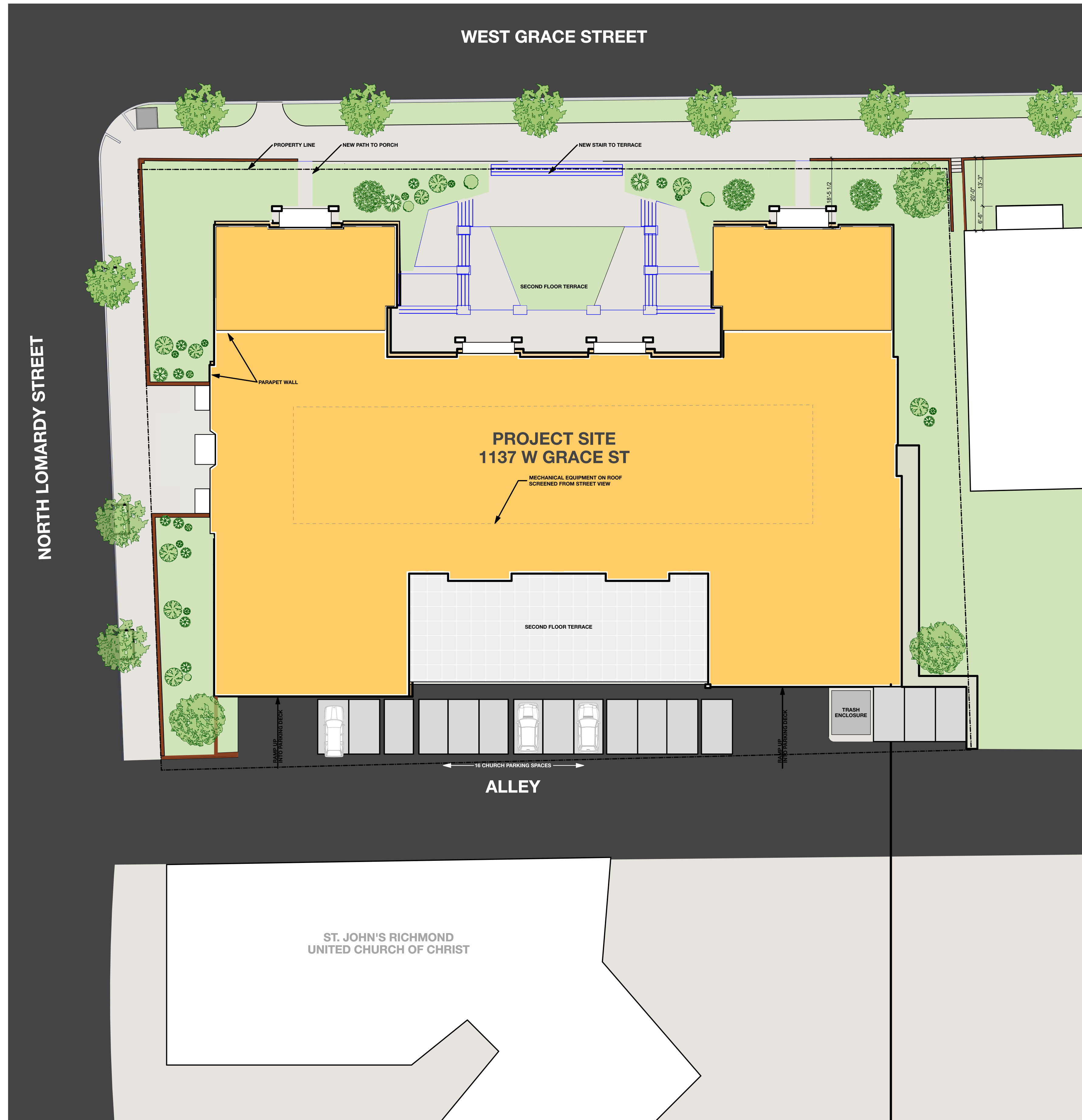

Grace & Lombardy
 1137 W. Grace St. Richmond VA

project #: 17.28
 date: 1/8/18

ENLARGED SITE PLAN

A.2

313 N. Adams Street
 Richmond, VA 23220
 1 804.644.4761
 1 804.644.4763
walterPARKS
 ARCHITECT



Grace & Lombardy
1137 W. Grace St. Richmond VA

project #: 17.28
date: 1/8/18

SITE SECTION

A.3

313 N. Adams Street
Richmond, VA 23220
1 804.644.4761
1 804.644.4763
walterPARKS
ARCHITECT

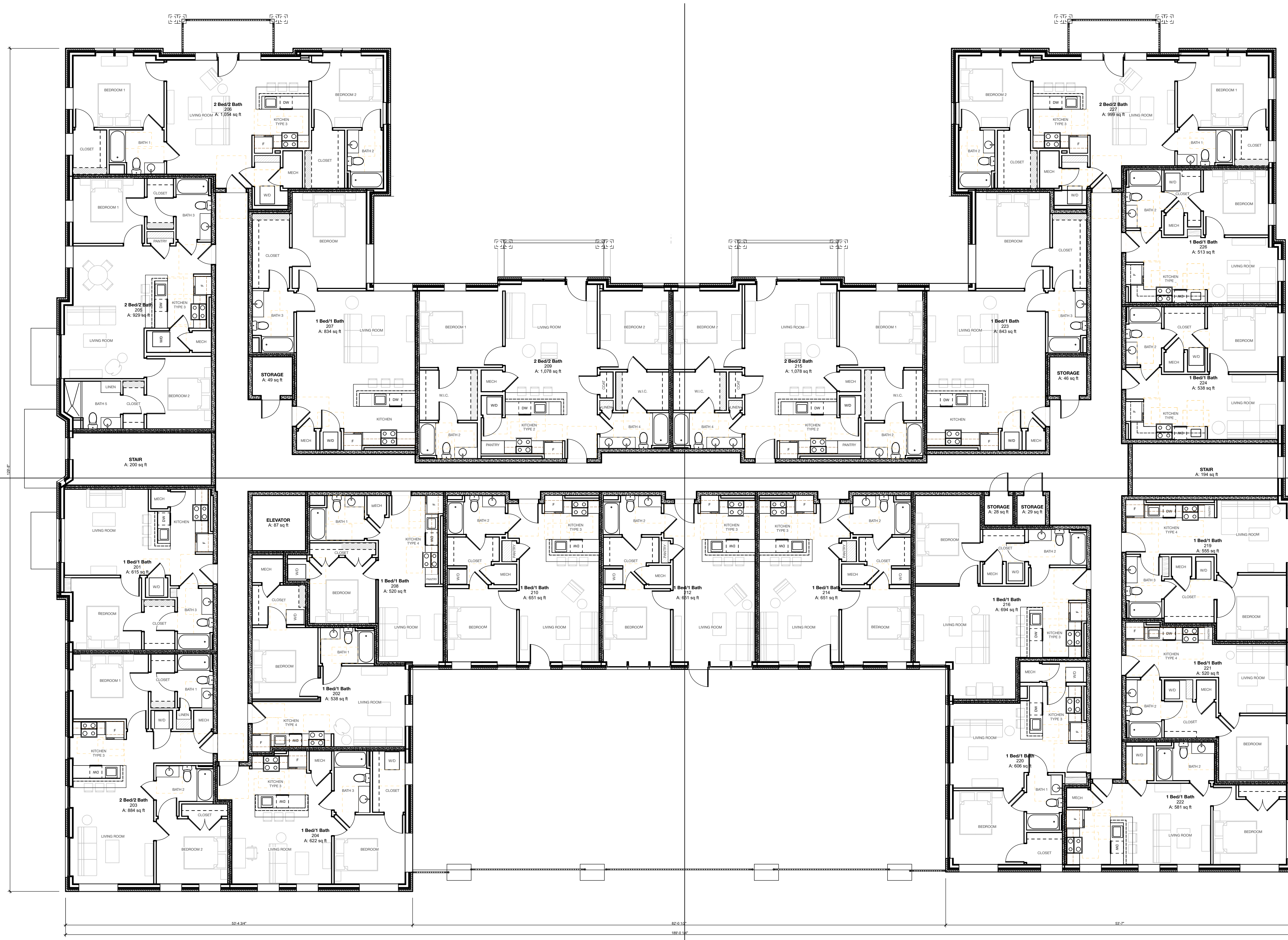

SECOND FLOOR PLAN
SCALE: 1/8" = 1'-0"

1

Grace & Lombardy
1137 W. Grace St. Richmond VA

project #: 17.28
date: 1/8/18

TYPICAL FLOOR PLAN

A.4

313 N. Adams Street
Richmond, VA 23220
1 804.644.4761
1 804.644.4763

walterPARKS
ARCHITECT



GRACE STREET ELEVATION
SCALE: 1/8" = 1'-0"

Grace & Lombardy
1137 W. Grace St. Richmond VA

project #: 17.28
date: 1/8/18

GRACE STREET ELEVATION

A.6

313 N. Adams Street
Richmond, VA 23220
1 804.644.4761
1 804.644.4763

walterPARKS
ARCHITECT



LOMBARDY STREET ELEVATION
SCALE: 1/8" = 1'-0"

Grace & Lombardy
1137 W. Grace St. Richmond VA

project #: 17.28
date: 1/8/18

LOMBARDY STREET ELEVATION

A.7

313 N. Adams Street
Richmond, VA 23220
1 804.644.4761
1 804.644.4763
walterPARKS
ARCHITECT



NORTH (ALLEY) ELEVATION
SCALE: 1/8" = 1'-0"

Grace & Lombardy
1137 W. Grace St. Richmond VA

project #: 17.28
date: 1/8/18

ALLEY ELEVATION

A.8

313 N. Adams Street
Richmond, VA 23220
1 804.644.4761
1 804.644.4763

walterPARKS
ARCHITECT

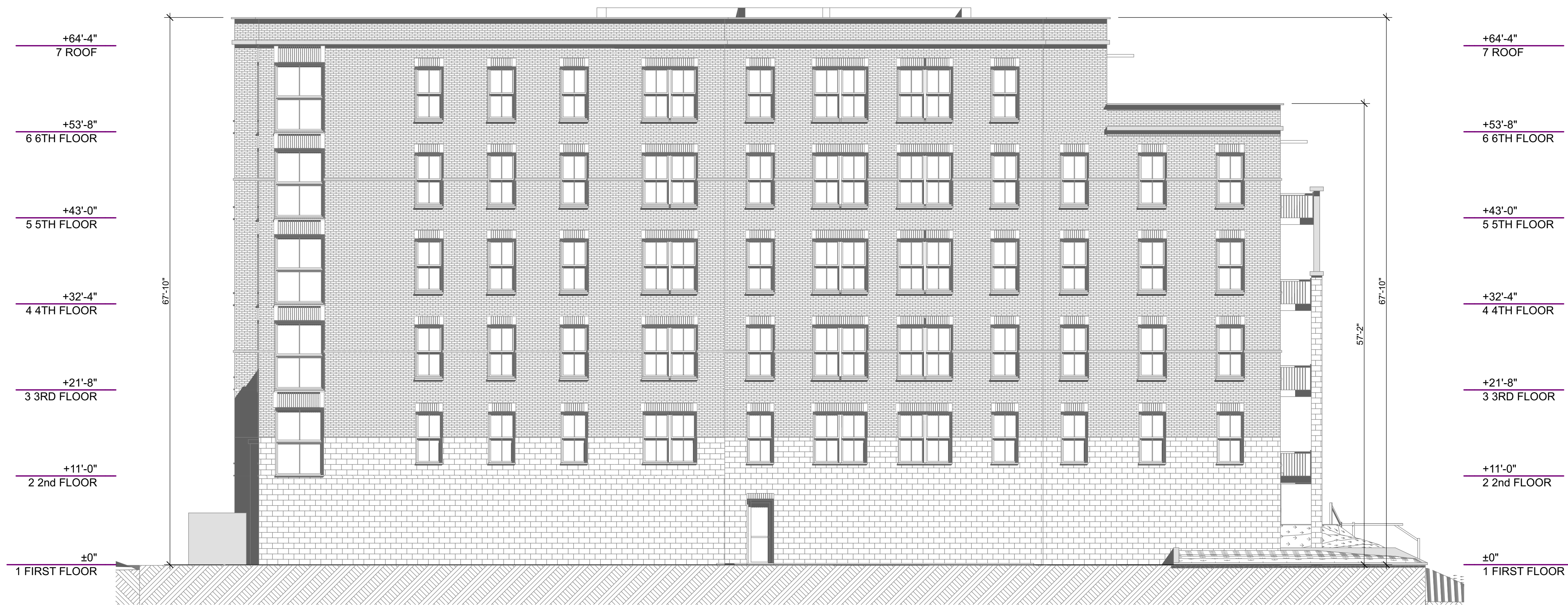

EAST ELEVATION
SCALE: 1/8" = 1'-0"

1

Grace & Lombardy
1137 W. Grace St. Richmond VA

project #: 17.28
date: 1/8/18

EAST ELEVATION

A.9

313 N. Adams Street
Richmond, VA 23220
1 804.644.4761
1 804.644.4763

walterPARKS
ARCHITECT

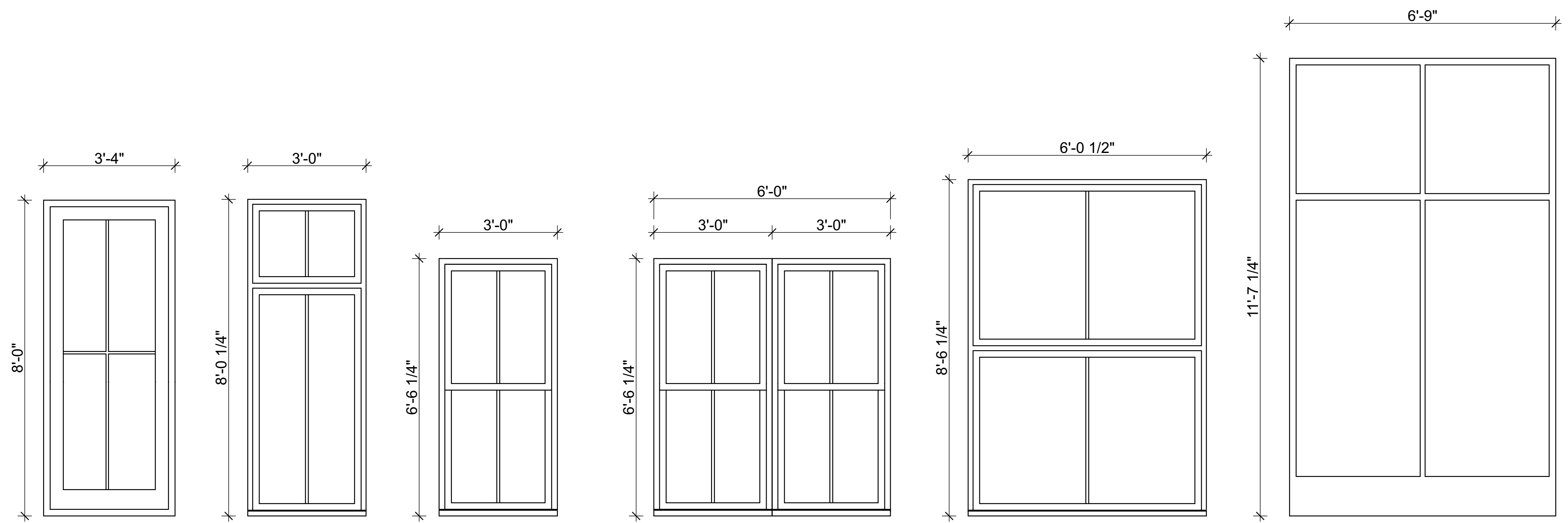

WINDOW ELEVATIONS
SCALE: 1/2" = 1'-0"

3

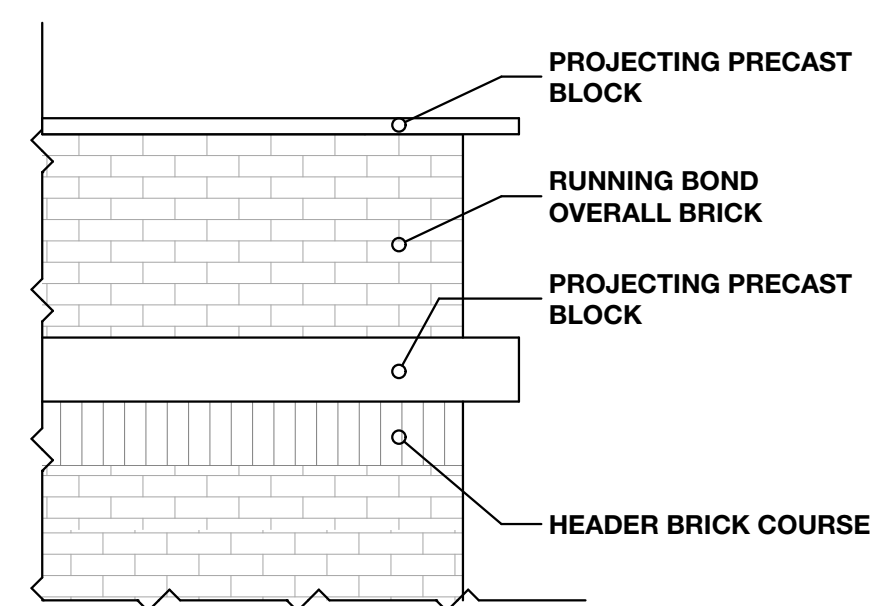

CORNICE DETAIL
SCALE: 1/2" = 1'-0"

2

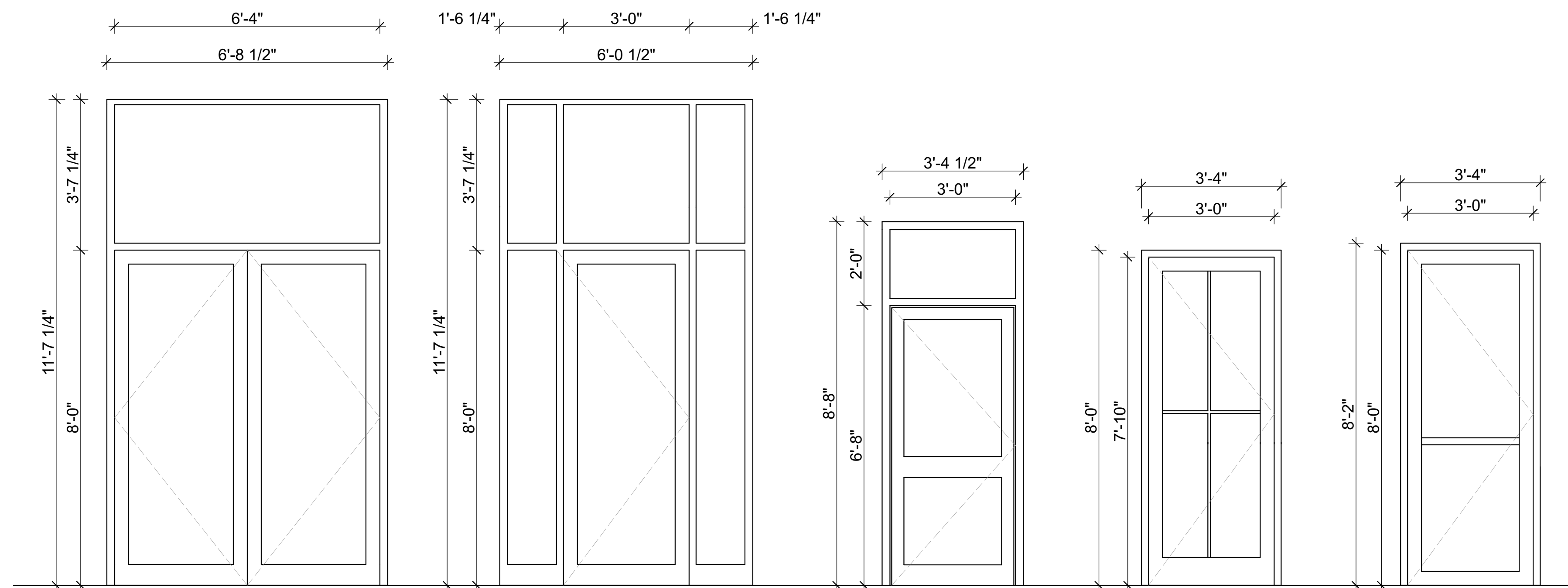

DOOR ELEVATIONS
SCALE: 1/2" = 1'-0"

1