



City of Richmond Department of Planning & Development Review

Location, Character, and Extent

LOCATION: Harwood St. and Minefee St. to Minefee St. and Gunn St.

COUNCIL DISTRICT: 6

PROPOSAL: Review of streetscape improvements consisting of the removal of parallel parking, and the addition of a bike lane and bioretention planters

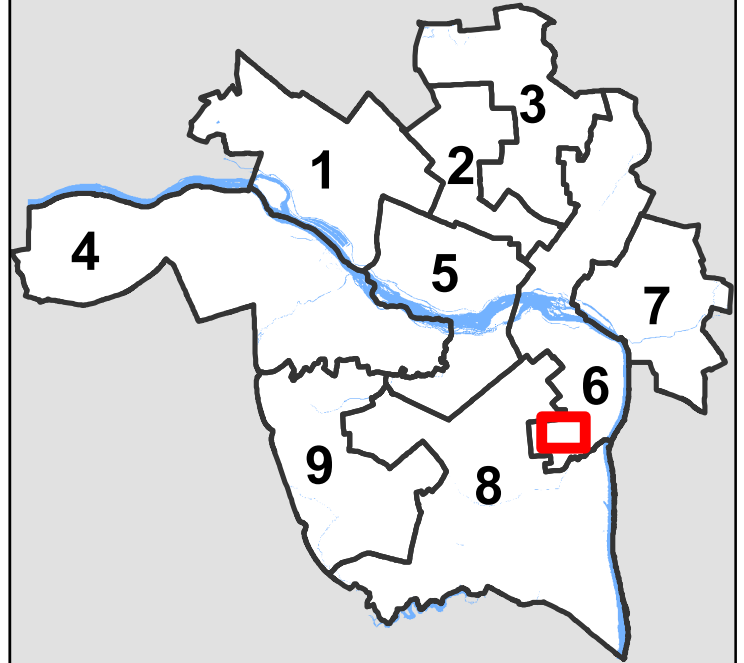

*For questions, please contact Josh Son
at 646-3741 or joshua.son@richmondgov.com*

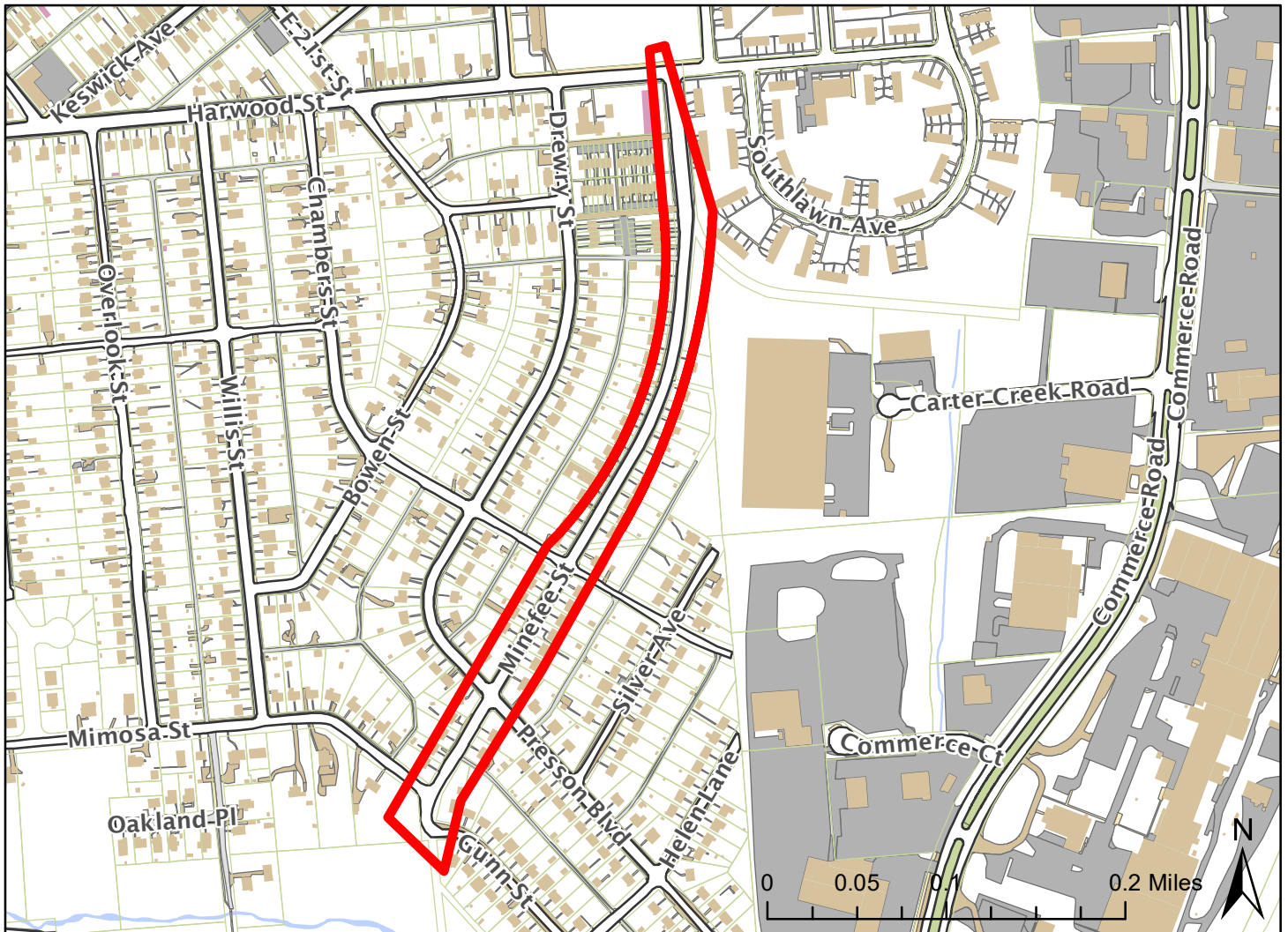



Application for URBAN DESIGN COMMITTEE Review

Department of Planning and Development Review
Planning & Preservation Division
900 E. Broad Street, Room 510
Richmond, Virginia 23219
(804) 646-6335

<http://www.richmondgov.com/CommitteeUrbanDesign>

Application Type

- Addition/Alteration to Existing Structure
 New Construction
 Streetscape
 Site Amenity

- Encroachment
 Master Plan
 Sign
 Other

Review Type

- Conceptual
 Final

Project Name: _____

Project Address: _____

Brief Project Description (this is not a replacement for the required detailed narrative) : _____

~~removal of parallel parking and addition of bike lane and bioretention planters~~ _____

Applicant Information

(on all applications other than encroachments, a City agency representative must be the applicant)

Name: _____ Email: _____

City Agency: _____ Phone: _____

Address: _____

Main Contact (if different from Applicant): _____

Company: _____ Phone: _____

Email: _____

Submittal Deadlines

All applications and support materials must be filed no later than 21 days prior to the scheduled meeting of the Urban Design Committee (UDC). Please see the schedule on page 3 as actual deadlines are adjusted due to City holidays. **Late or incomplete submissions will be deferred to the next meeting.**

Filing

Applications can be mailed or delivered to the attention of "Urban Design Committee" at the address listed at the top of this page. **It is important that the applicant discuss the proposal with appropriate City agencies, Zoning Administration staff, and area civic associations and residents prior to filing the application with the UDC.**

UDC Background

The UDC is a ten member committee created by City Council in 1968 whose purpose is to advise the City Planning Commission on the design of projects on City property or right-of-way. The UDC provides advice of an aesthetic nature in connection with the performance of the duties of the Commission under Sections 17.05, 17.06 and 17.07 of the City Charter. The UDC also advises the Department of Public Works in regards to private encroachments in the public right-of-way.



URBAN DESIGN COMMITTEE PRESENTATION

FINAL REVIEW

BELLEMEADE GREEN STREET

RICHMOND, VIRGINIA



JANUARY 2019

TABLE OF CONTENTS

1. PROJECT OVERVIEW

2. STAKEHOLDER ENGAGEMENT

3. CONCEPTUAL DESIGN

4. FINAL DESIGN

*Planting Design

*Bike Lane Design



PROJECT OVERVIEW

This project builds upon the work of the Bellemeade Walkable Watershed Plan, completed in 2012. The plan worked towards integrating the flow of people and stormwater, calling for environments that are safe and inviting for people as well as ecologically functional and sustainable. Minefee Street was identified as an opportunity for implementing a Green Street, connecting Hillside Court with Goodes Creek. The James River Association (JRA) funded the design of this project with various grants and corporate donations. Once the design is approved by the UDC and CPC the JRA will move forward with soliciting funds for implementation and construction. Construction timing will be dependent on when funding becomes available. The JRA is also partnering with Groundwork RVA on future landscape maintenance of the streetscape with their GreenTeam program. There is already a GreenTeam that works in the Oakgrove-Bellemeade Elementary School area.

The green street proposal calls for a range of sustainable stormwater practices to be implemented along Minefee Street. These practices slow stormwater, allow it to naturally infiltrate back into the ground, and keep it from flowing directly into the storm drains and Goodes Creek. Ultimately, these practices help to create a healthier watershed and a healthier Chesapeake Bay. Alongside the environmental elements, streetscape improvements aim to create a more inviting, safe, educational, and beautiful neighborhood. A bicycle/pedestrian pathway connects to the Bellemeade Community Center and the Oak Grove-Bellemeade Elementary School; this serves as a safe route for community members and students to cross over Goodes Creek to these destinations. Future interpretive elements along this pathway will explain the natural processes of the new Green Street. Together, these environmental and infrastructural improvements work together to make a healthier and more connected neighborhood.

The project team has had multiple meetings with the two neighborhood civic associations (Bellmeade and Hillside Court) where the project has received support. We have also met with various City departments to review the design including DPU, Transportation, and Parks.

EXISTING CONDITIONS AERIAL

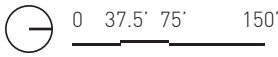

Preliminary research included an inventory of existing conditions using aerial photography, City of Richmond GIS data, and site visits to photograph streetscape character and verify storm drain locations, bus stops, and right-of-way widths. This inventory was used to further analyze the site and create a basemap for stakeholder activities.

The Minefee Street corridor was broken into four sections based on block structure and streetscape character: Harwood to the edge of the woods near Hillside Court (A), edge of woods to Chambers Street (B), Chambers Street to Presson Boulevard (C), and Presson Boulevard to Gunn Street (D) which terminates at the new trail connector to the Bellemeade Community Center.



EXISTING CONDITIONS PHOTOS



GUNN STREET ← PRESSON AVENUE

D

PRESSON AVENUE ← CHAMBERS STREET

C

CHAMBERS STREET ← EDGE OF WOODS

B

EDGE OF WOODS ← HARWOOD STREET

A

STAKEHOLDER ENGAGEMENT



STAKEHOLDER ENGAGEMENT

3north partnered with JRA, Groundwork RVA's Green Team, and local students to identify opportunities for innovation, community enhancement, and streetscape improvements along the Minefee corridor. Components and amenities were divided into 5 key categories that correlate with the goals established in the Bellemeade Neighborhood Walkable Watershed Plan, which include:

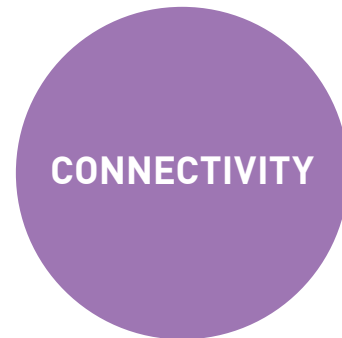



The first team identified strategies along the full length of the Minefee Street corridor. Signage identifies the new bike lane upon turning onto Minefee. A community garden and orchard is located at Hillside Court, as well as a dog pick-up station for the pet owners who walk along Minefee.

Moving down the street, rain gardens with native plantings help manage stormwater runoff. Offset curb extensions provide traffic calming, while crosswalks are designed to incorporate artistic elements.

Street trees line the entire corridor, leading toward a park at the terminus of Minefee Street, where a trailhead leads to the Bellemeade Community Center. A bus stop and a range of park amenities are located here.

CONNECTIVITY				SAFETY				WATER + ENVIRONMENT				GREEN SPACE + COMMUNITY				EDUCATION + AWARENESS		
BUS STOP	PAINTED BIKE LANE	BIKE ROUTE	BIKE LANE	CROSSWALK ART	OFFSET CURB EXTENSION	CURB EXTENSION PLANTER	BIKE LANE	PERMEABLE PAVING	RAIN GARDEN	NATIVE PLANTS	FRUIT TREES	DOG PICK-UP STATION	EDIBLE PLANTS	FRUIT TREES	STREET TREES	BMP SIGNAGE	CROSSWALK ART	STORM DRAIN ART
								EDIBLE PLANTS	PERMEABLE PARKING			WATER FOUNTAINS	BIKE RACKS	RECYCLING RECEPTACLES	TRASH RECEPTACLES			



Team two started their bike lane on Harwood Street. Tree islands divide this street, slowing traffic and creating an urban tree canopy. Upon entering Minefee Street signage and a speed hump slows traffic. Bioswales line the trees, adjacent to a painted bike lane. Trees are planted within the bioswales, continuing the tree canopy down Minefee.

Crosswalk art is located at street intersections, along with pedestrian crossing signals. Interpretive signage explains stormwater management practices for pedestrians walking alongside the bioswales.

Permeable pavers are used in parallel parking areas. A park is located at the bottom of the hill, with a trail connecting to the Bellemeade Community Center.

CONNECTIVITY				SAFETY				WATER + ENVIRONMENT				GREEN SPACE & COMMUNITY				EDUCATION + AWARENESS			
BUS STOP	PAINTED BIKE LANE	BIKE ROUTE	BIKE LANE	SAFETY SIGNAGE	SPEED HUMP	PAINTED BIKE LANE	CROSSWALK LIGHTING	ARTFUL BIO-RETENTION	TREE ISLANDS	STREET TREES	PERMEABLE PAVING	TREE CANOPY	MODERN FURNISHINGS	WATER FOUNTAINS	TRASH RECEPTACLES	BMP SIGNAGE	FRUIT TREES	ARTFUL BIORETENTION	INTERACTIVE BIOSWALE
				CROSSWALK ART	PEDESTRIAN SIGNAL	RAISED CROSSWALK	STREET LIGHTS	BIOSWALE	INTERACTIVE BIOSWALE	BIO-RETENTION	FRUIT TREES	DOG PICK-UP STATION	RECYCLING RECEPTACLES			STORMDRAIN ART	CROSSWALK ART		

CONCEPTUAL DESIGN

CONCEPTUAL DESIGN

The design for Minefee Street incorporates a range of design strategies that create a more sustainable and enjoyable streetscape. Overall, the design creates connections from the Harwood/Minefee Street intersections down to Goodes Creek and, ultimately, Bellemeade Community Center and Oak Grove-Bellemeade Elementary School. Sustainable stormwater practices are integrated throughout the corridor, including permeable parallel parking spaces, a pervious concrete bicycle/pedestrian pathway, bioretention planters along the streetscape, a bioswale that runs alongside the pathway, and a wet meadow that captures excess stormwater runoff.

Safety is a critical element of the design; the pathway is separated from the road by a planted bioswale, and raised crosswalks/intersections serve to slow traffic. Art/murals are incorporated into these crosswalks. The urban tree canopy is greatly enhanced along Minefee Street, while plantings within the bioretention basins and bioswales utilize native plantings. Natives provide habitat for insects, animals, and pollinators, and also often require less maintenance than traditional plantings. Maintenance of these plantings will be provided by the Groundworks RVA Green Team. The design also includes a wide range of community-focused features, including a community garden with raised beds and an orchard adjacent to Hillside Court, a community pavilion within the community garden, interpretive signage along Minefee Street, recycling and trash receptacles, and new park features alongside Goode Creek. This park will contain a water bottle filling station, a dog walking station, and a trailhead to the Bellemeade Community Center and Oak Grove-Bellemeade Elementary School.



MINEFEE STREET CONCEPT DIAGRAM



MINEFEE STREET CONCEPTUAL PLAN



NOTES

- A** Hillside Court
- B** Community Garden
- C** Garden Pavilion
- D** Orchard/Food Forest
- E** Permeable Paving Parallel Parking
- F** Permeable Paving Bicycle Lane
- G** Bioretention Planter
- H** Crosswalk Art
- I** Bus Shelter
- J** Park
- K** Wet Meadow
- L** Trail to Oak Grove - Bellemeade Elementary School



PERMEABLE PARKING

Permeable pavers are used within parallel parking areas. This allows water to infiltrate back into the ground instead of flowing into the storm drain.



RAISED CROSSWALK

This raised crosswalk serves as both a crossing from the bike/ped pathway to the community garden as well as a traffic calming measure, reducing vehicular speed along this straight stretch of Minefee Street.



BIKE PATH

A permeable asphalt bike lane, striped for two-way bike traffic is separated from the existing Minefee Street sidewalk by a planted strip. This bike lanes runs the entire length of Minefee Street, beginning with a bus stop at Harwood and connecting to a path that leads to the Bellemeade Community Center.

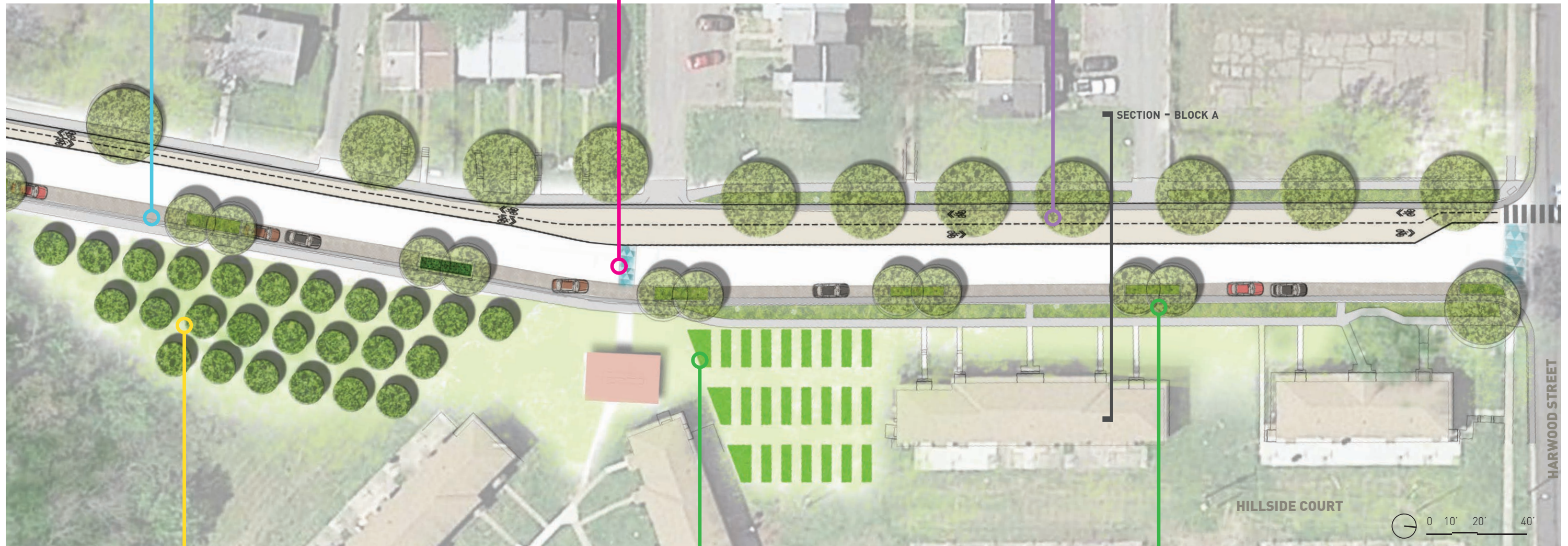

FOOD FOREST / ORCHARD

Fruit trees provide fresh fruit to the residents of Minefee Street and Hillside Court, and the food forest utilizes edible woodland species. Both provide educational opportunities on food production and sustainable agriculture.



COMMUNITY GARDEN

Garden plots provide neighborhood residents with space to grow fresh vegetables. A garden pavilion anchors the garden, serving as a space for education as well as community gatherings.



PLANTED DIVIDER STRIP

A planted strip separates the parallel parking areas from the existing sidewalk. Trees and seasonally interesting landscape plantings create an attractive linear garden environment that helps slow stormwater and allows it to infiltrate into the ground.

STREETSCAPE SECTION - BLOCK A

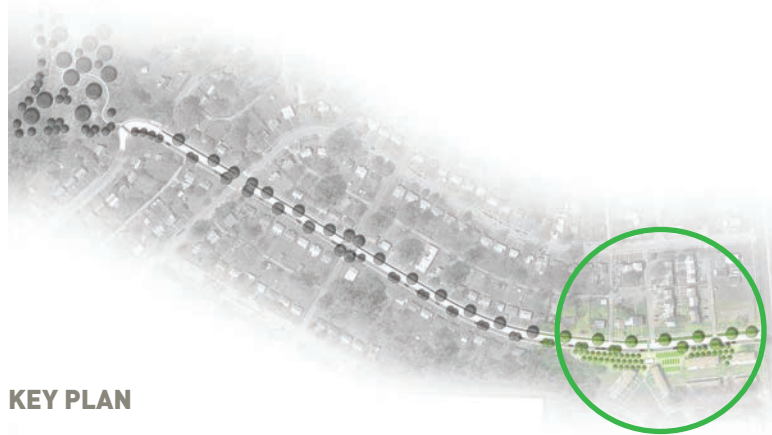
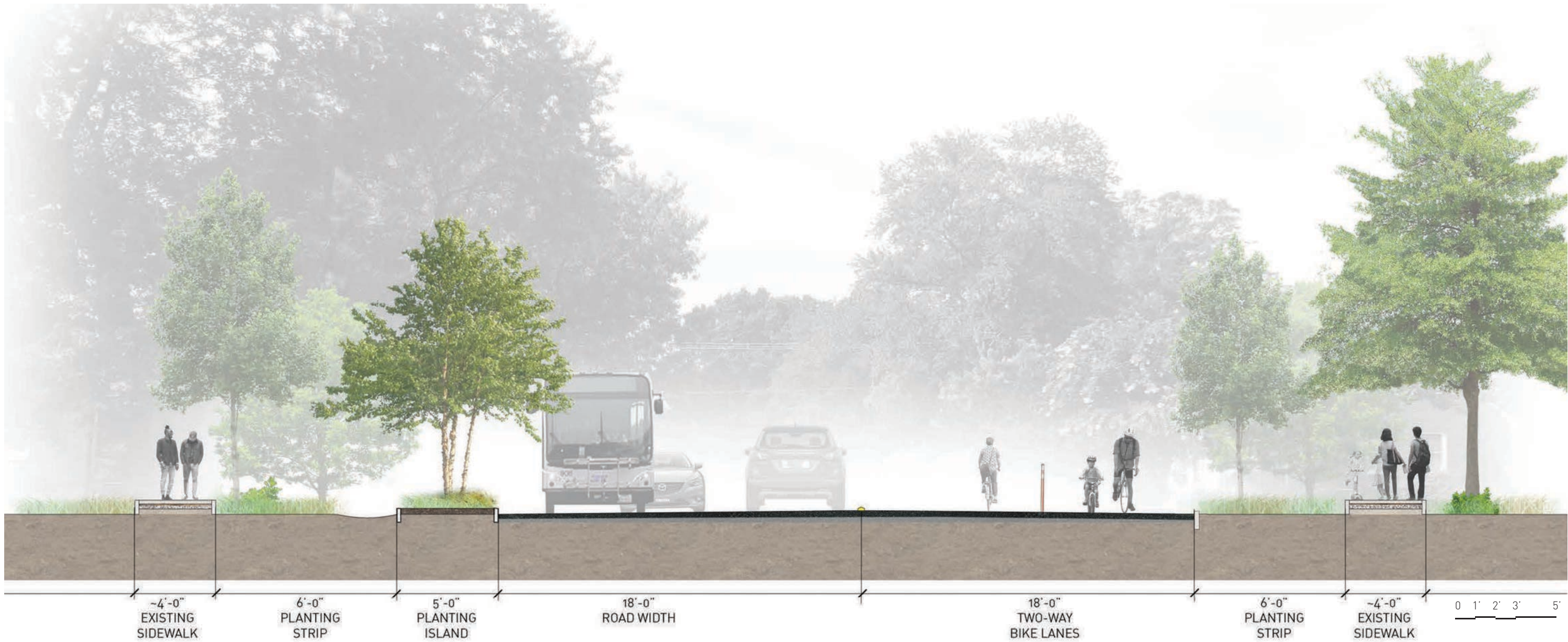

KEY PLAN

COMMUNITY HUB

This block adjacent to Hillside Court serves as a community hub. A range of activities, from classes to socials to picnics, can take place within the community pavilion at the community garden. The garden and food forest becomes a central space where neighbors can congregate while enjoying and working in the garden. Food grown here provides fresh, organic options to community members and enhances the menu at Oak Grove-Bellemeade Elementary School nearby. The start of the bicycle and trail begins on this block and moves down towards Goodes Creek, where it eventually connects to a trail system going to the Bellemeade Community Center. A bus stop is positioned nearby, allowing for connections to be made throughout Richmond.



COMPOST & RECYCLING

Visible and accessible trash, recycling, and pet clean-up receptacles are incorporated into the new community food production & green spaces. A dedicated composting area near the garden beds minimizes household waste while providing fertilizer for garden plots.



CROSSWALK ART

Crosswalks incorporate murals and artistic elements, creating inviting and engaging intersections.



BIORETENTION

Bioretention planters collect runoff from Minefee Street, allowing it to infiltrate back into the ground or into an underdrain system. These areas utilize native plants, and provide habitat.



EDUCATION TRAIL

Along the new pedestrian and cycling trail, icons representing birds, insects, plants, and aquatic wildlife teach students about water, soil, plants, and habitat as they walk to and from school. Signage and graphics along the path provide educational activities.



PERMEABLE PARKING

Permeable paving is used within parallel parking areas. This allows water to infiltrate back into the ground instead of flowing into the storm drain.



PLANTED ISLAND

Planted islands provide additional greenspace along the parallel parking areas and match the scale and rhythm of the bioretention planters. These islands provide more planting space for shrubs and smaller trees and create an attractive linear garden with seasonal interest.



BIKE PATH

A permeable asphalt bike lane, striped for two-way bike traffic is separated from the existing Minefee Street sidewalk by a planted strip. This bike lanes runs the entire length of Minefee Street, beginning with a bus stop at Harwood and connecting to a path that leads to the Bellemeade Community Center.

STREETSCAPE SECTION - BLOCK B



KEY PLAN

GREEN STREET ELEMENTS

The typical streetscape along the Bellemeade Green Street is composed of an 8' wide two-way bike lane, ~18' vehicular travel lane, an 8' parallel parking lane alternating with bioretention planters (4 total), planting islands, and the existing City sidewalks. Street trees will augment the existing canopy along Minefee and native plants will be incorporated into new bioswale planting strips along the corridor. Environmental graphics including educational signage, art, and playful, engaging paving patterns will increase awareness of sustainable technologies and create an educational trail along the length of Minefee.



STRUCTURAL SOIL

Structural soil will be used in the planting areas along the green street in order to ensure the health of newly planted street trees and to protect sidewalks and paths. Structural soil will also increase the infiltration of water in the planting strips, slowing runoff.

FINAL DESIGN

The final design for Minefee Street incorporates many of the elements of the conceptual design but focuses in on a base scheme that addresses the two biggest design goals: stormwater treatment and bicycle safety. As additional funding becomes available in the future more of the design elements from the conceptual plan will be incorporated such as interpretive signage and public art.

Sustainable stormwater practices are integrated throughout the corridor using five bioretention planters along the streetscape, and by adding new street trees along the west side of Minefee St. Bicycle safety is accomplished by removing parallel parking along the west side of Minefee Street and replacing it with a two-way bike lane separated from cars with flexible bollards.



PLANTING DESIGN

With the objective of bringing beauty and interest throughout the seasons, the east side of the street's planting strategy is divided into three different planting palettes according to planter (A,B and C). The west side is comprised of attractive native large tree species.

The three types of planters on the east side, include a combination of a medium ornamental trees, shrubs with seasonal interest and perennials or grasses. The plant palette for the Bioretention planters would alternate between two types of shrub species with a consistent tree selection. Plant species were selected for ease of maintenance and are intended to gradually fill in and secure the soil of the bioretention planters.

The two street tree selections for the west side of the street are River Birches and Northern Red Oaks, which alternate down the street according to the scale of the existing streetscape elements.

PLANTING PLAN

NOTES

- A** Planter Type A
- B** Planter Type B
- C** Bio-Retention Planters

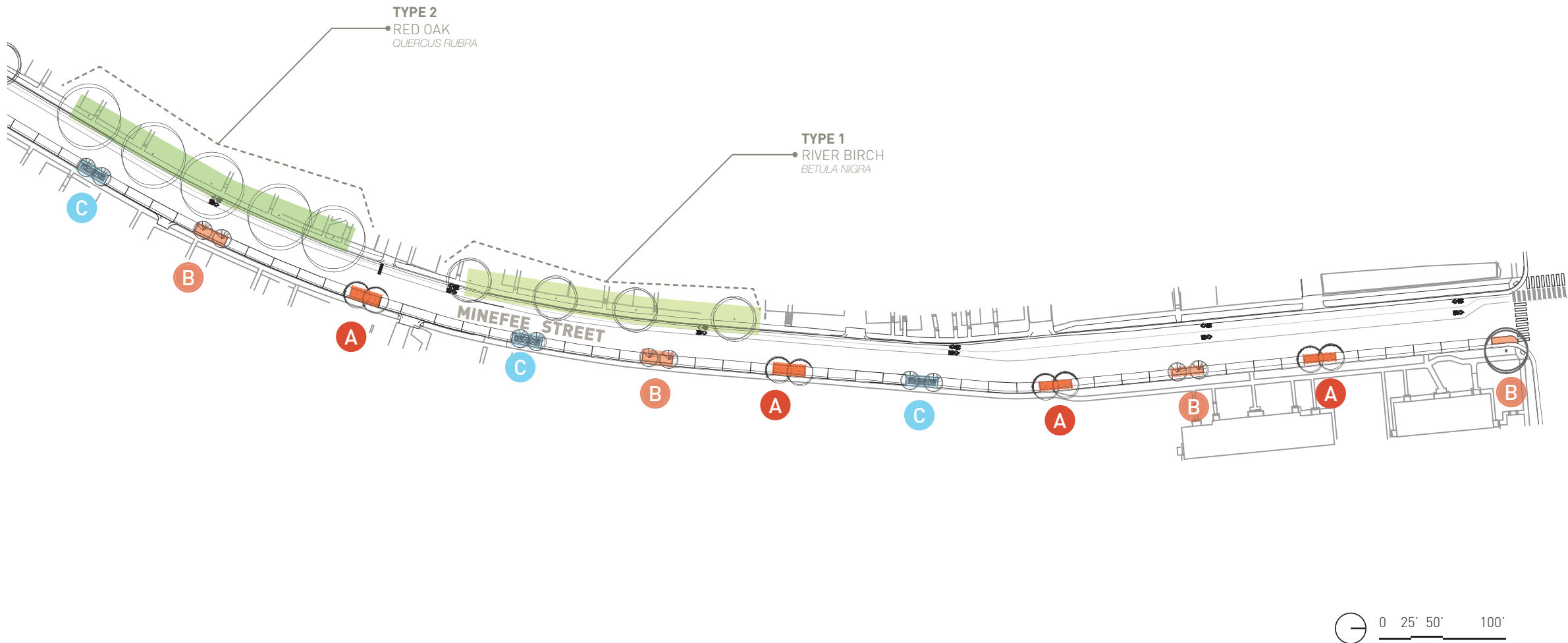

PLANTING STRATEGY

With the objective of bringing beauty and interest throughout the seasons, the east side of the street's planting strategy is divided into three different planting palettes according to planter (A,B and C). The west side is comprised of attractive native large tree species.

The three types of planters on the east side, include a combination of a medium ornamental trees, shrubs with seasonal interest and perennials or grasses.

The plant palette for the Bio-retention planters would alternate between two types of shrub species with a consistent tree selection. Plant species were selected for ease of maintenance and are intended to gradually fill in and secure the soil of the bio-retention planters.

The two street tree selections for the west side of the street are River Birches and Northern Red Oaks, which alternate down the street according to the scale of the existing streetscape elements.

KEY PLAN



PLANTING PLAN

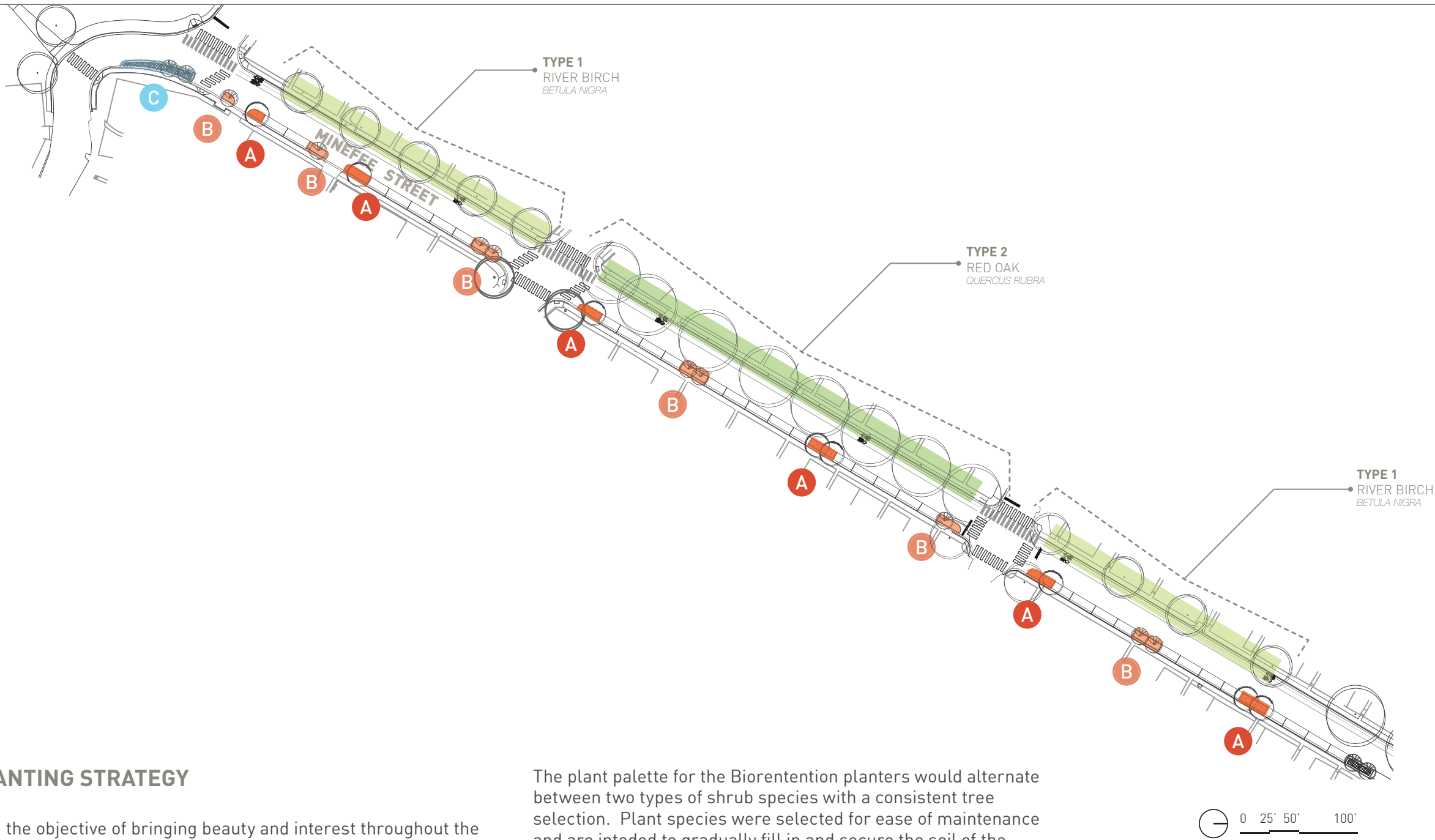

NOTES

- A** Planter Type A
- B** Planter Type B
- C** Bio-Retention Planters

PLANTING STRATEGY

With the objective of bringing beauty and interest throughout the seasons, the east side of the street's planting strategy is divided into three different planting palettes according to planter (A, B and C). The west side is comprised of attractive native large tree species.

The three types of planters on the east side, include a combination of a medium ornamental trees, shrubs with seasonal interest and perennials or grasses.

The plant palette for the Bio-retention planters would alternate between two types of shrub species with a consistent tree selection. Plant species were selected for ease of maintenance and are intended to gradually fill in and secure the soil of the bio-retention planters.

The two street tree selections for the west side of the street are River Birches and Northern Red Oaks, which alternate down the street according to the scale of the existing streetscape elements.

KEY PLAN

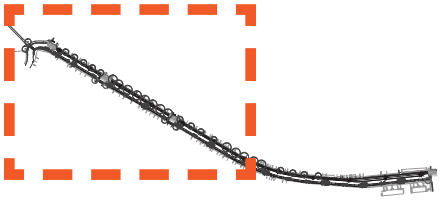

PLANTING PALETTE

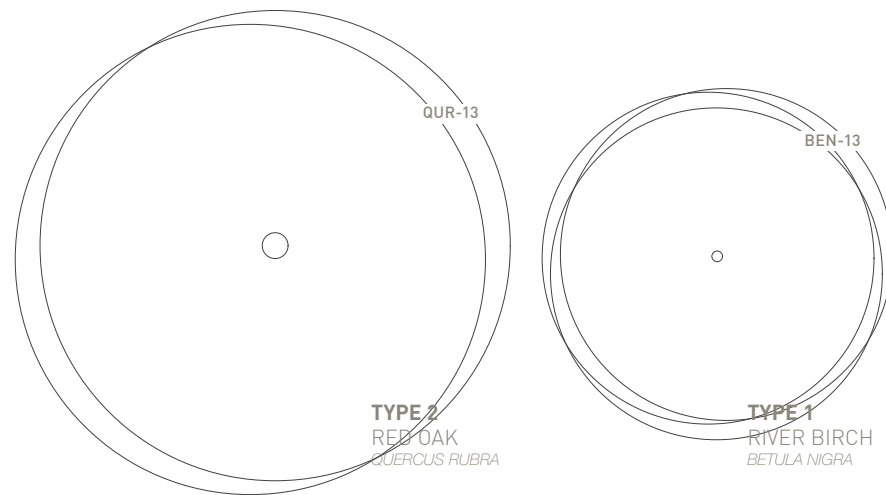
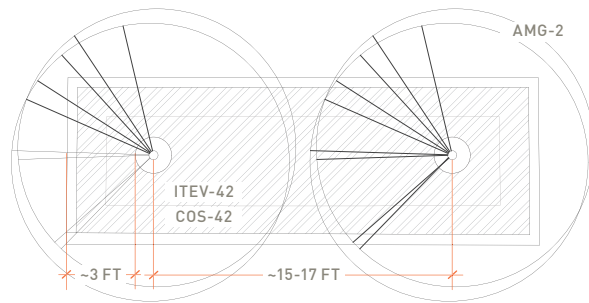
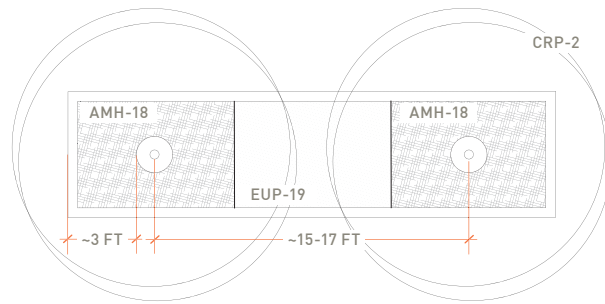
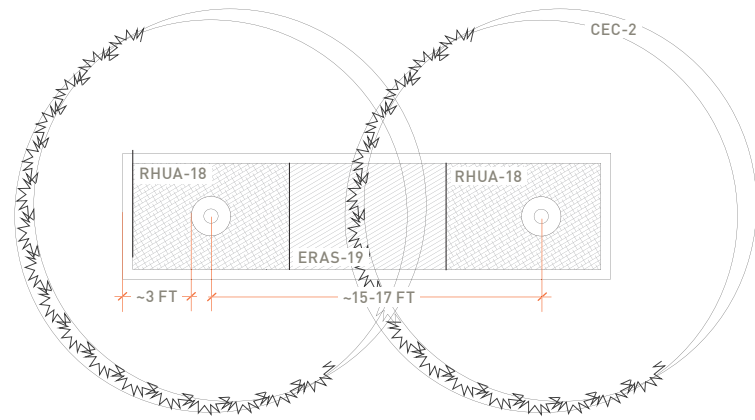

PLANTER TYPE A

- 'Gro-Lo' Sumac - 12"H x18"W (Rhus aromatica)
- Purple Love Grass - 3 Gal (Eragrostis spectabilis)
- Eastern Redbud - (Cercis canadensis)



PLANTER TYPE B

- Purple Coneflower - 1 Gal (Echinacea Purpurea)
- Amsonia - 3 Gal (Amsonia hubrichtii)
- Winter King Hawthorn - 12'H (Crataegus phaenopyrum)



PLANTER TYPE C

Bio- Retention Planters:

- Shrub 1:
Arctic Fire Dwarf Dogwood - 18"Hx18"W (Cornus sericea)
- Shrub 2:
Little Henry Sweetspire - 18"Hx18"W (Itea virginica)
- Autumn Brilliance Serviceberry - 12'H (Amelanchier x grandiflora)



WEST STREET TREES

- Type 1:
River Birch 3" Cal. (Betula nigra)
- Type 2:
Northern Red Oak - 3" Cal. (Quercus rubra)



*Sizes listed are at installation

REVISED BIKE LANE DESIGN

The design of the bike lane was modified to meet the concerns and comments brought up by DPW:

There is not enough space within the confines of the existing road section (~34' face of curb to face of curb) to properly design a two-way cycle track and have enough space for dedicated on-street parking and lane widths for the design vehicle (transit/school buses); therefore, we have come up with the proposed 6' protected bicycle lane, which at its narrowest sections include the existing gutter pan and the 2-foot painted buffer.

This proposed section allows us to accomplish the desired goal of providing a protected bike lane for elementary students and recreation center travelers during peak hours in the a.m while allowing us to maximize parking space, "green" tree well and bioretention features (8' wide), and provide 10' travel lanes.

10' is below the required threshold for transit; however, DPW was willing to allow the concession based on the low volume of the road, the existing condition (parking on both sides), and the relative infrequency of bus transit.

All bike lane infrastructure fits between existing curb lines of the street. No modifications to existing curb line location is proposed.

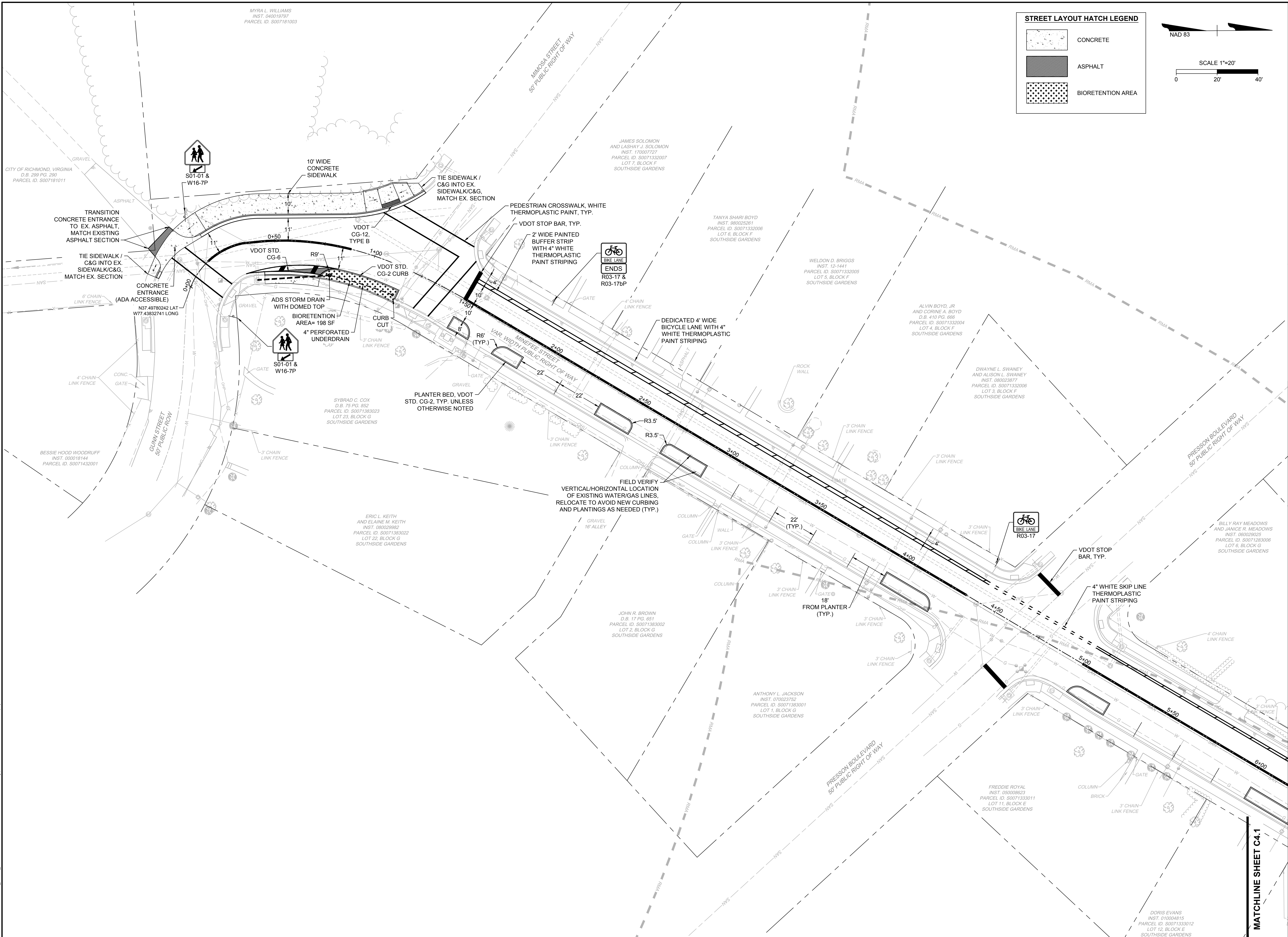

STREET LAYOUT HATCH LEGEND

- CONCRETE
- ASPHALT
- BIORETENTION AREA

NAD 83

SCALE 1"=20'

0 20' 40'

THIS DRAWING PREPARED AT THE
CORPORATE OFFICE
1001 Builders Parkway, Suite 300 | Richmond, VA 23225
TEL 804.200.0500 FAX 804.580.1016 www.timmons.com

YOUR VISION ACHIEVED THROUGH OURS.

DATE	REVISION DESCRIPTION
01/11/2019 <td></td>	

DRAWN BY	L. COFFMAN
DESIGNED BY	L. COFFMAN
CHECKED BY	A. CREEL
SCALE	1" = 20'

TIMMONS GROUP

BELLEMEADE GREEN STREET IMPROVEMENTS
BELLEMEADE DISTRICT - RICHMOND - VIRGINIA

STREET LAYOUT PLAN

JOB NO.	39986
SHEET NO.	C4.0

L:\2020\39986-Bellemeade_Green_SheetDWG\Sheet\CD\39986-C4.0.LAYO.dwg | Printed on 1/19/2019 5:52 PM | by Laune Coffman

These plans and associated documents are the exclusive property of TIMMONS GROUP and may not be reproduced in whole or in part and shall not be used for any purpose whatsoever, inclusive, but not limited to construction, bidding, and/or construction staking without the express written consent of TIMMONS GROUP.

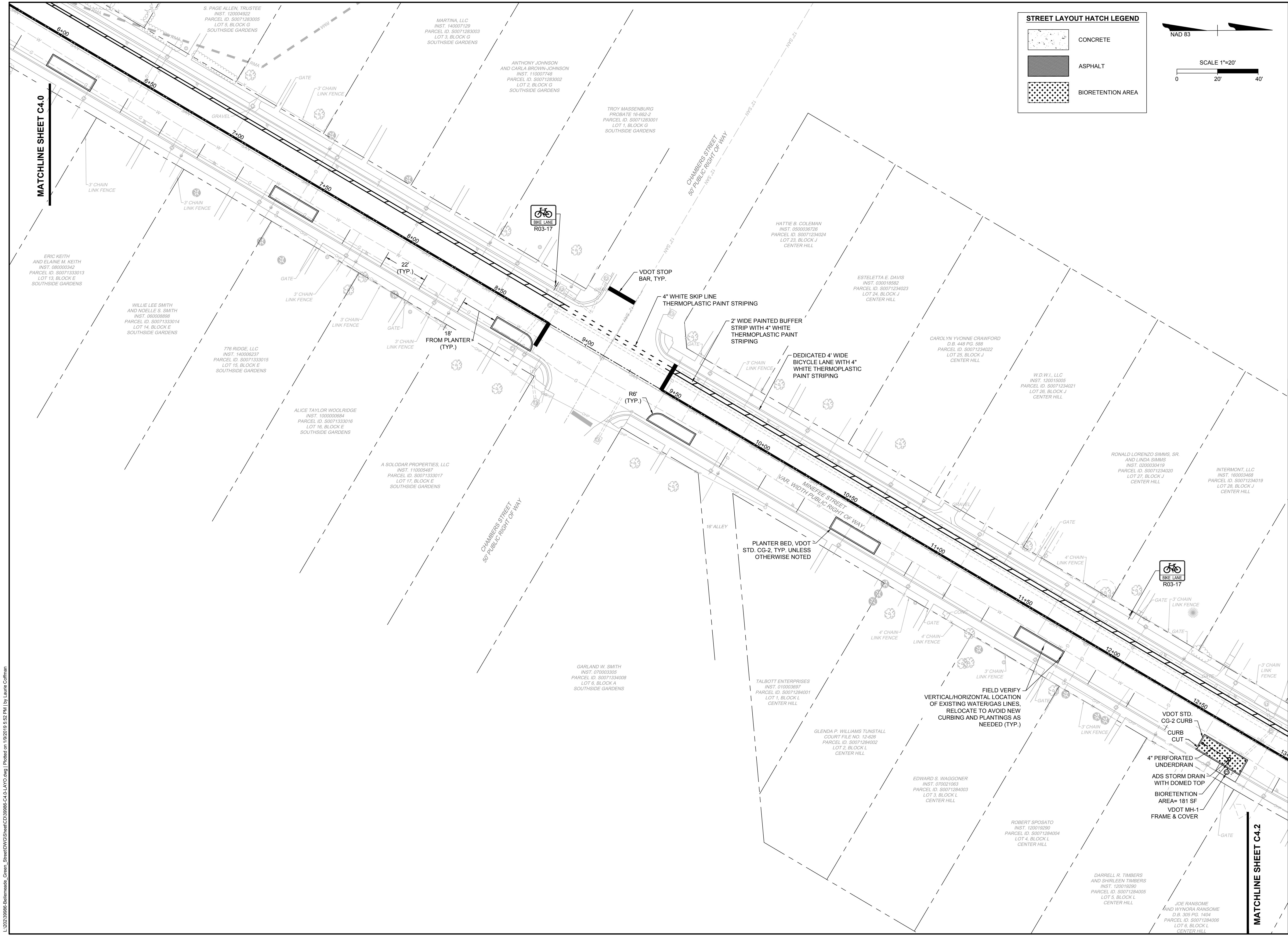

STREET LAYOUT HATCH LEGEND

- CONCRETE
- ASPHALT
- BIORETENTION AREA

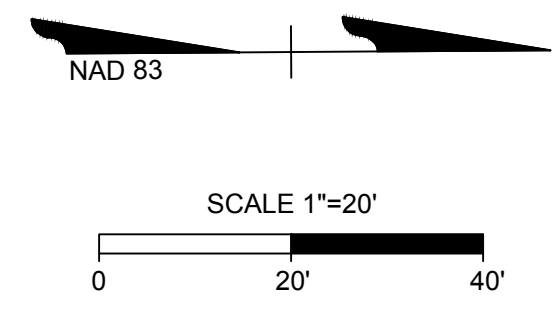

MATCHLINE SHEET C4.0

MATCHLINE SHEET C4.2

TIMMONS GROUP

BELLEMEADE GREEN STREET IMPROVEMENTS BELLEMEADE DISTRICT - RICHMOND - VIRGINIA STREET LAYOUT PLAN

THIS DRAWING PREPARED AT THE
CORPORATE OFFICE
100 Builders Parkway, Suite 300 | Richmond, VA 23225
TEL 804.200.0500 FAX 804.580.1016 www.timmons.com

YOUR VISION ACHIEVED THROUGH OURS.

REVISION DESCRIPTION	DATE

DATE: 01/11/2019
DRAWN BY: L. COFFMAN
DESIGNED BY: L. COFFMAN
CHECKED BY: A. CREEL
SCALE: 1" = 20'

JOB NO.	39986
SHEET NO.	C4.1

L:\2020\39986-Bellemeade_Green_SheetDWG\Sheet\CD\39986-C4.0.LAYO.dwg | Printed on 1/11/2019 5:52 PM | by Lavine Coffman

These plans and associated documents are the exclusive property of TIMMONS GROUP and may not be reproduced in whole or in part and shall not be used for any purpose whatsoever, inclusive, but not limited to construction, bidding, and/or construction staking without the express written consent of TIMMONS GROUP.

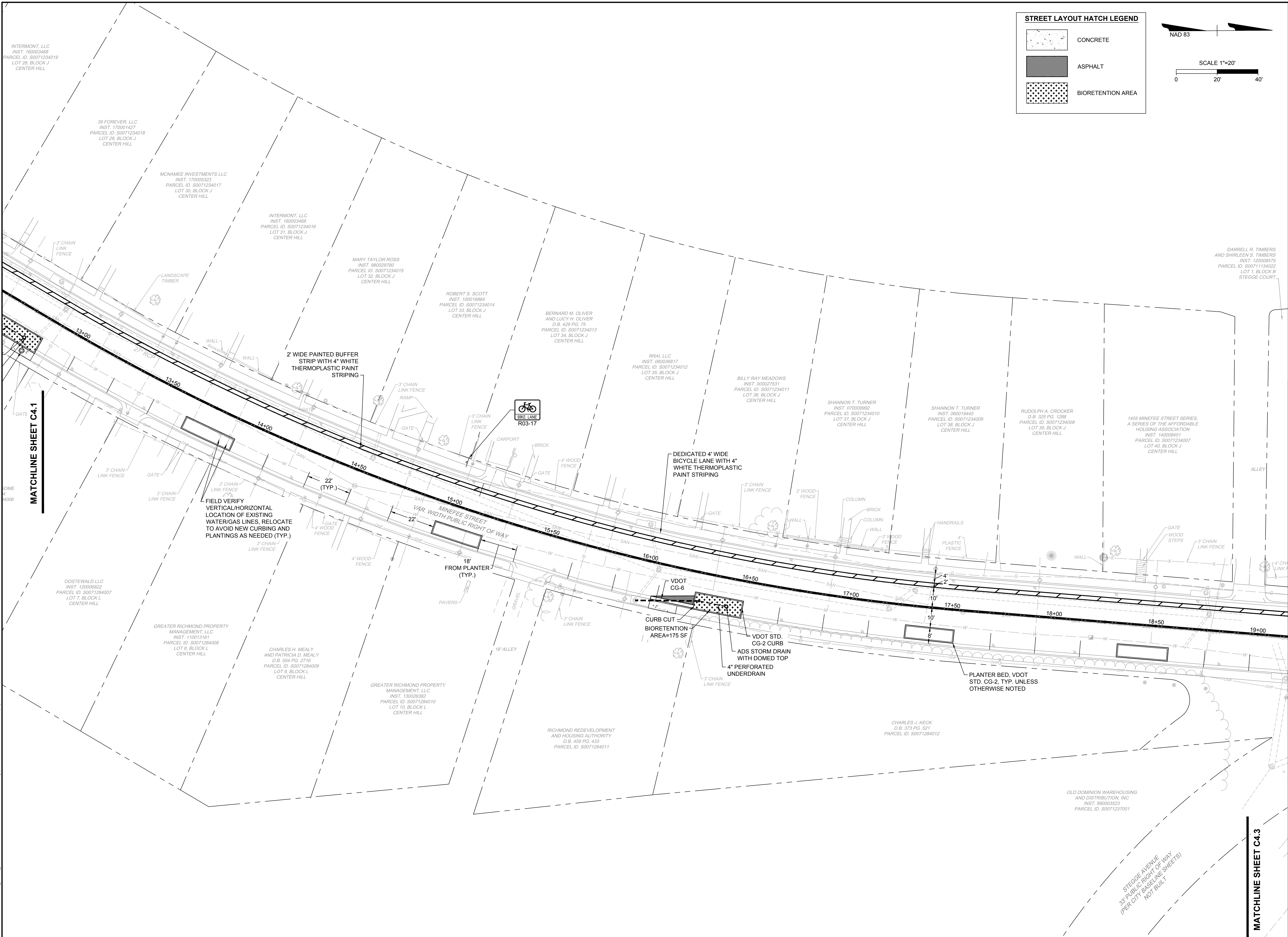

STREET LAYOUT HATCH LEGEND

- CONCRETE
- ASPHALT
- BIORETENTION AREA

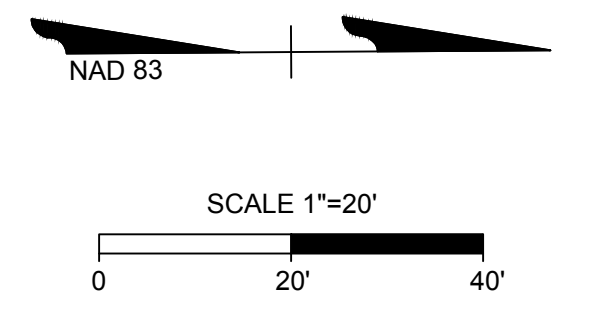

MATCHLINE SHEET C4.1

MATCHLINE SHEET C4.3

THIS DRAWING PREPARED AT THE
CORPORATE OFFICE
 1001 Builders Parkway, Suite 300 | Richmond, VA 23225
 TEL 804.200.0500 FAX 804.580.1016 www.timmons.com

YOUR VISION ACHIEVED THROUGH OURS.

DATE
 01/11/2019
 DRAWN BY
 L. COFFMAN
 DESIGNED BY
 L. COFFMAN
 CHECKED BY
 A. CREEL
 SCALE
 1" = 20'

TIMMONS GROUP

BELLEMEADE GREEN STREET IMPROVEMENTS
 BELLEMEADE DISTRICT - RICHMOND - VIRGINIA
 STREET LAYOUT PLAN

JOB NO.
 39986
 SHEET NO.
 C4.2

These plans and associated documents are the exclusive property of TIMMONS GROUP and may not be reproduced in whole or in part and shall not be used for any purpose whatsoever, inclusive, but not limited to construction, bidding, and/or construction staking without the express written consent of TIMMONS GROUP.

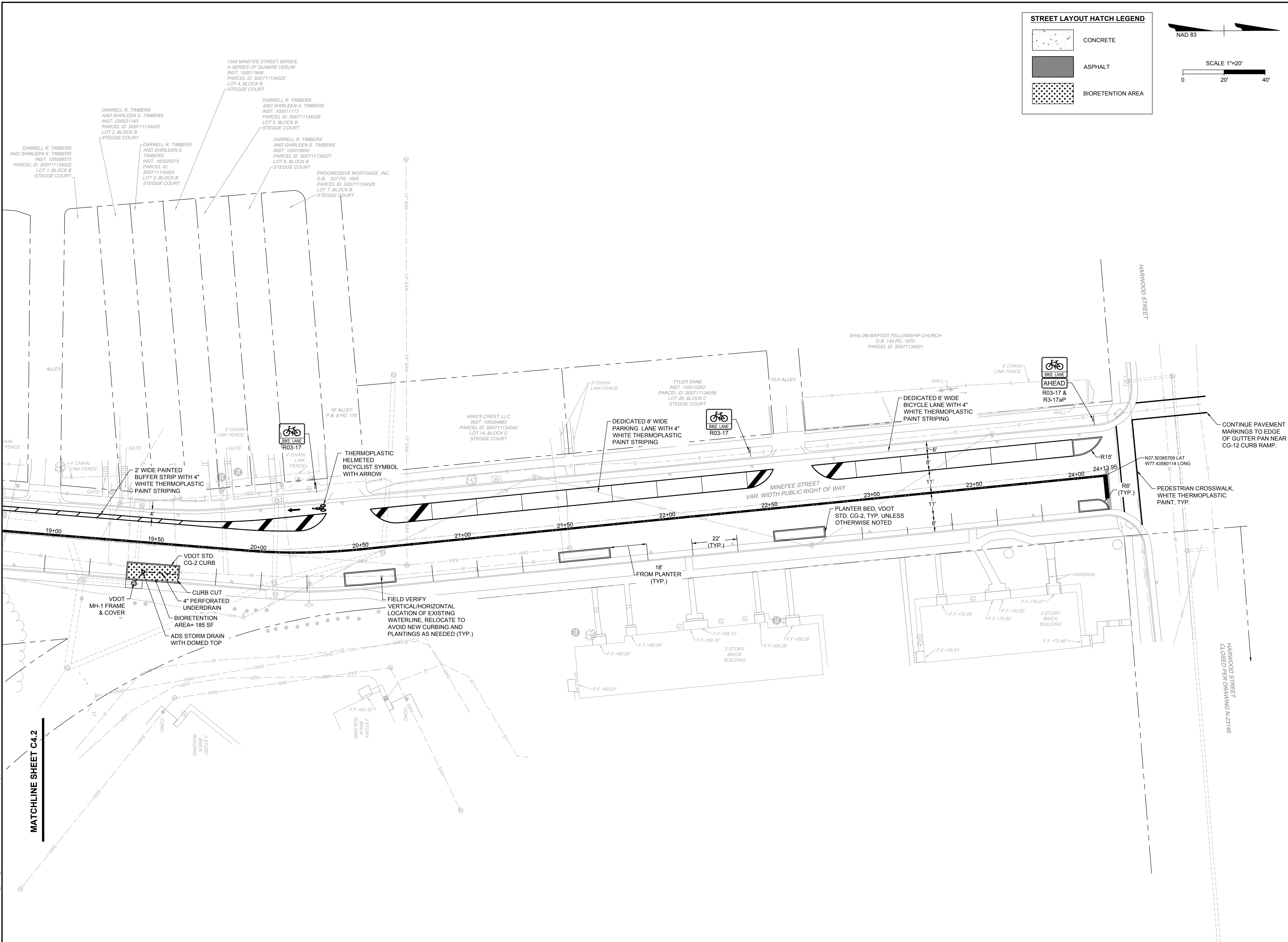

STREET LAYOUT HATCH LEGEND

- CONCRETE
- ASPHALT
- BIORETENTION AREA

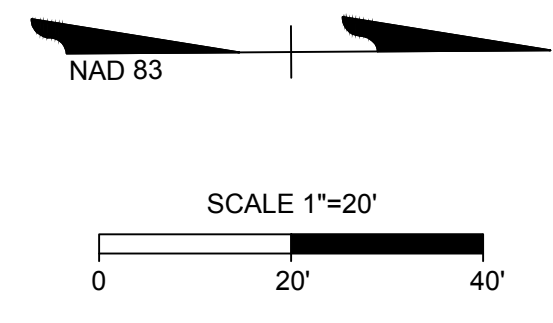

L:\2020\39986-Bellemeade_Green_Sheet\DWG\Sheet\CD\39986-C4.0-LAYO.dwg | Plotted on 1/11/2019 5:52 PM | by Laurie Coffman

MATCHLINE SHEET C4.2

THIS DRAWING PREPARED AT THE
CORPORATE OFFICE
1001 Builders Parkway, Suite 300 | Richmond, VA 23225
TEL 804.200.0500 FAX 804.580.1016 www.timmons.com

YOUR VISION ACHIEVED THROUGH OURS.

REVISION DESCRIPTION	DATE

DATE	01/11/2019
DRAWN BY	L. COFFMAN
DESIGNED BY	L. COFFMAN
CHECKED BY	A. CREEL
SCALE	1" = 20'

TIMMONS GROUP

BELLEMEADE GREEN STREET IMPROVEMENTS
BELLEMEADE DISTRICT - RICHMOND - VIRGINIA

STREET LAYOUT PLAN

JOB NO.	39986
SHEET NO.	C4.3

These plans and associated documents are the exclusive property of TIMMONS GROUP and may not be reproduced in whole or in part and shall not be used for any purpose whatsoever, inclusive, but not limited to construction, bidding, and/or construction staking without the express written consent of TIMMONS GROUP.

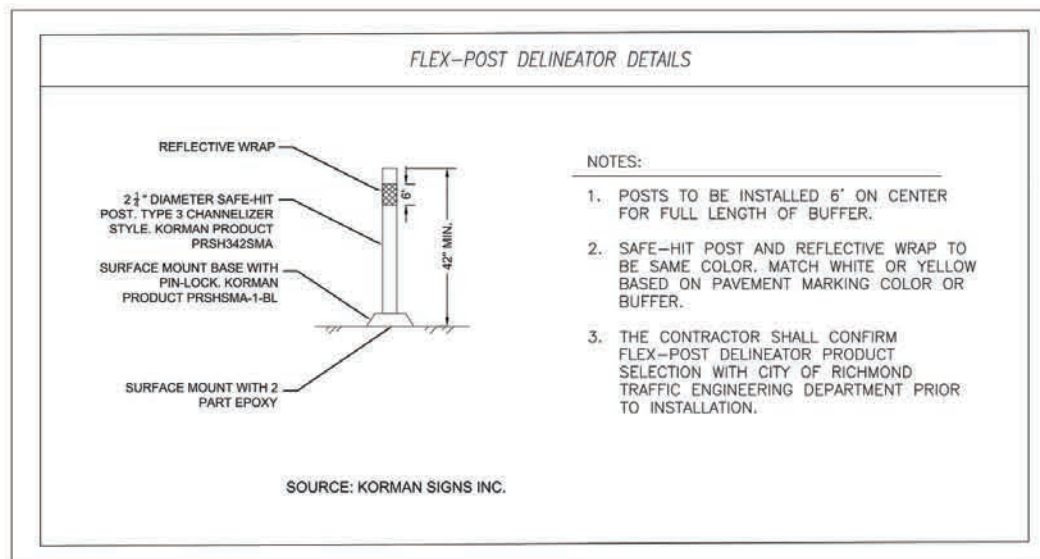
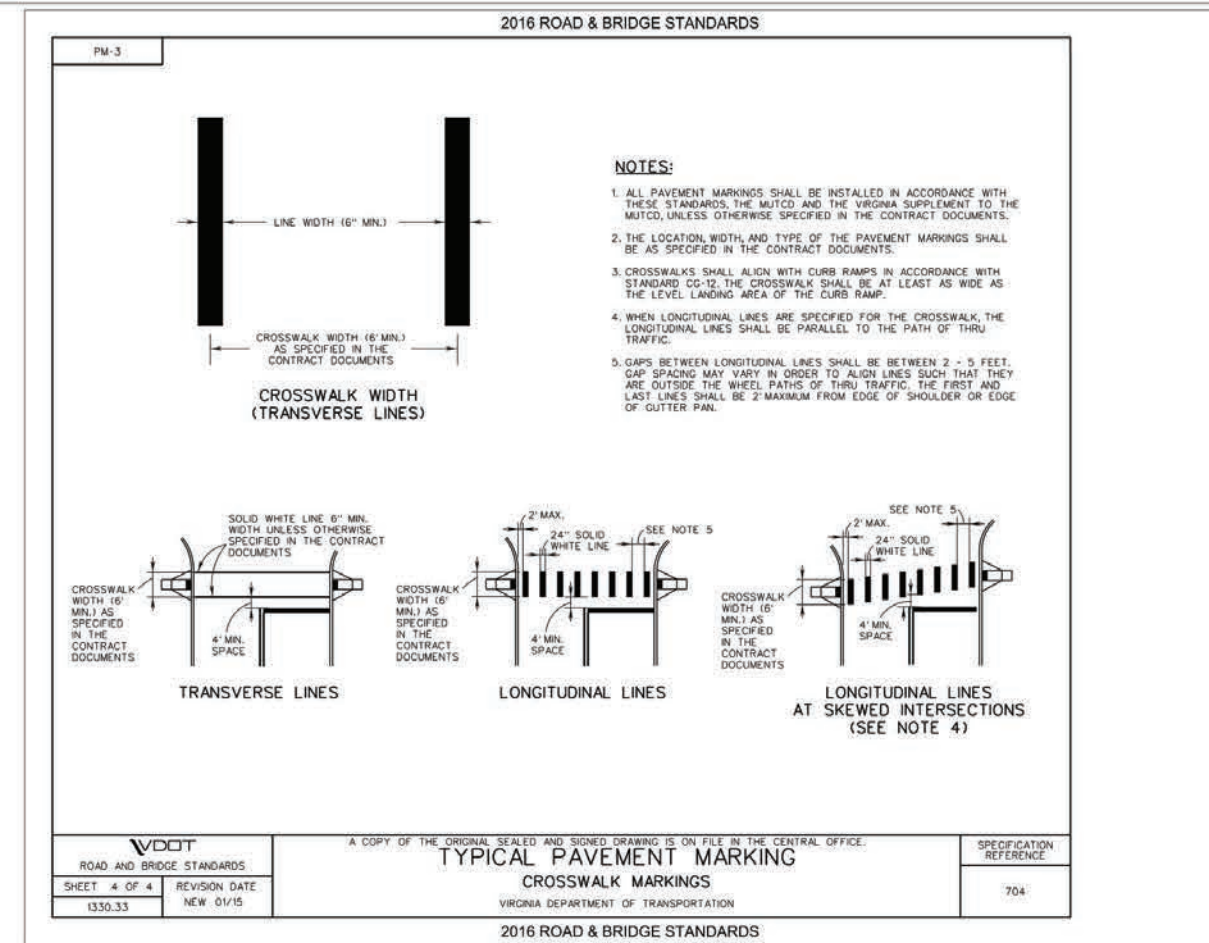
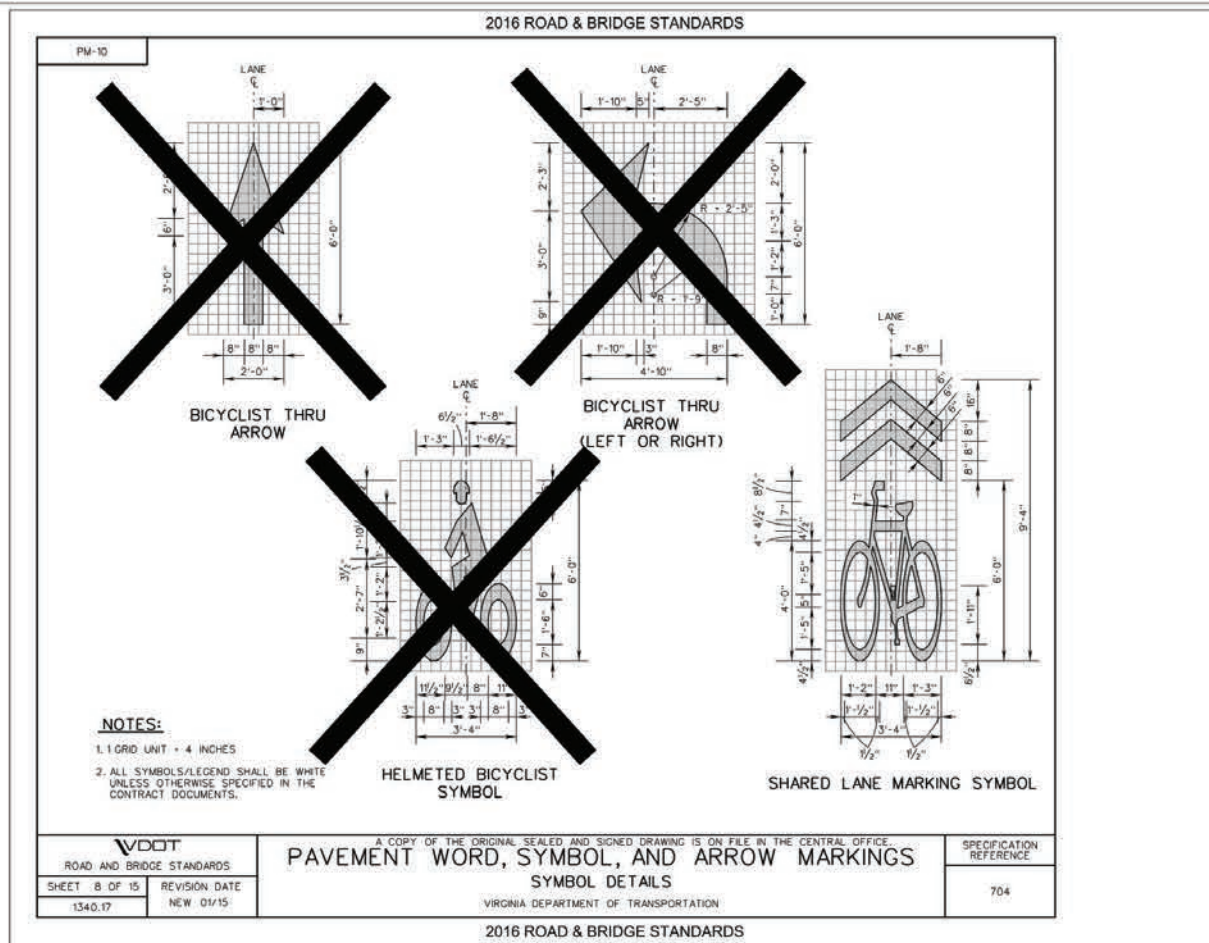

EXAMPLE OF DUAL BIKE/PEDESTRIAN CROSSWALK W/ 2-WAY BIKE LANE

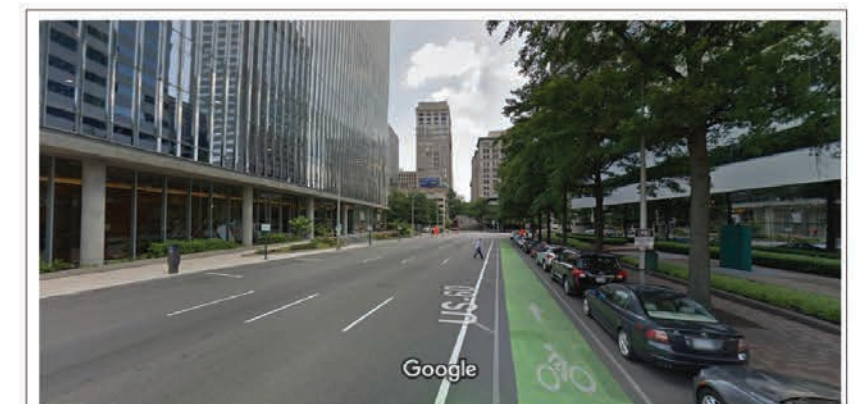

PHOTO CREDIT: GOOGLEMAPS.COM
EXAMPLE OF GREEN BIKE LANE PAINT

NOTES AND DETAILS

BELLEMEADE GREEN STREET IMPROVEMENTS - 11/13/2018
URBAN DESIGN COMMITTEE SUBMITTAL - NOT FOR CONSTRUCTION