

INTRODUCED: April 27, 2026

AN ORDINANCE No. 2026-099

To authorize the special use of the property known as 310 North 25th Street for the purpose of up to one two-family attached dwelling and two dwelling units within an accessory structure, upon certain terms and conditions. (7th District)

Patron – Mayor Avula (By Request)

Approved as to form and legality
by the City Attorney

PUBLIC HEARING: MAY 26 2026 AT 6 P.M.

WHEREAS, the owner of the property known as 310 North 25th Street, which is situated in a UB Urban Business District, desires to use such property for the purpose of up to one two-family attached dwelling and two dwelling units within an accessory structure, which use, among other things, is not currently allowed by sections 30-433.2 and 30-433.5, concerning yard requirements, of the Code of the City of Richmond (2020), as amended; and

WHEREAS, in accordance with section 17.11 of the Charter of the City of Richmond (2020), as amended, it has been made to appear that, if granted subject to the terms and conditions set forth in this ordinance, the special use granted by this ordinance will not be detrimental to the safety, health, morals and general welfare of the community involved, will not tend to create

AYES: 8 NOES: 0 ABSTAIN: _____

ADOPTED: MAY 26 2026 REJECTED: _____ STRICKEN: _____

congestion in streets, roads, alleys and other public ways and places in the area involved, will not create hazards from fire, panic or other dangers, will not tend to overcrowding of land and cause an undue concentration of population, will not adversely affect or interfere with public or private schools, parks, playgrounds, water supplies, sewage disposal, transportation or other public requirements, conveniences and improvements, and will not interfere with adequate light and air; and

WHEREAS, (i) the City Planning Commission has conducted a public hearing to investigate the circumstances and conditions upon which the Council is empowered to authorize such use, (ii) the City Planning Commission has reported to the Council the results of such public hearing and investigation and its recommendations with respect thereto, and (iii) the Council has conducted a public hearing on this ordinance at which the person in interest and all other persons have had an opportunity to be heard;

NOW, THEREFORE,

THE CITY OF RICHMOND HEREBY ORDAINS:

§ 1. **Finding.** Pursuant to section 30-1050.1 of the Code of the City of Richmond (2020), as amended, the Council hereby finds that the special use set forth in and subject to the terms and conditions of this ordinance will not (i) be detrimental to the safety, health, morals and general welfare of the community involved, (ii) tend to create congestion in streets, roads, alleys and other public ways and places in the area involved, (iii) create hazards from fire, panic or other dangers, (iv) tend to overcrowding of land and cause an undue concentration of population, (v) adversely affect or interfere with public or private schools, parks, playgrounds, water supplies, sewage disposal, transportation or other public requirements, conveniences and improvements, or (vi) interfere with adequate light and air.

§ 2. **Grant of Special Use Permit.**

(a) Subject to the terms and conditions set forth in this ordinance, the property known as 310 North 25th Street and identified as Tax Parcel No. E000-0338/007 in the 2026 records of the City Assessor, being more particularly shown on a survey entitled “Plat Showing Improvements on #310 North 25th Street, City of Richmond, Virginia,” prepared by Goodfellow, Jalbert, Beard, and Associates Inc., and dated April 23, 2024, a copy of which is attached to and made a part of this ordinance, hereinafter referred to as “the Property,” is hereby permitted to be used for the purpose of up to one two-family attached dwelling and two dwelling units within an accessory structure, hereinafter referred to as “the Special Use,” substantially as shown on the plans entitled “Plat Showing Proposed Improvements on #310 North 25th Street, City of Richmond, Virginia,” prepared by Goodfellow, Jalbert, Beard, and Associates Inc., and dated May 8, 2025, and “Jones Residence,” prepared by C. L. Shade Drafting, and dated June 16, 2025, hereinafter referred to, collectively, as “the Plans,” copies of which are attached to and made a part of this ordinance.

(b) The adoption of this ordinance shall constitute the issuance of a special use permit for the Property. The special use permit shall inure to the benefit of the owner or owners of the fee simple title to the Property as of the date on which this ordinance is adopted and their successors in fee simple title, all of which are hereinafter referred to as “the Owner.” The conditions contained in this ordinance shall be binding on the Owner.

§ 3. **Special Terms and Conditions.** This special use permit is conditioned on the following special terms and conditions:

(a) The Special Use of the Property shall be as up to one two-family attached dwelling and two dwelling units within an accessory structure, substantially as shown on the Plans.

(b) No off-street parking shall be required for the Special Use.

(c) The height of the Special Use shall not exceed two stories, substantially as shown on the Plans.

(d) All building materials, elevations, and site improvements shall be substantially as shown on the Plans, subject to the conditions set forth in the Certificate of Appropriateness issued by the Commission of Architectural Review, approved November 25, 2025, in response to Application No. COA-175460-2025.

(e) All mechanical equipment serving the Property shall be located or screened so as not to be visible from any adjoining public right-of-way.

§ 4. **Supplemental Terms and Conditions.** This special use permit is conditioned on the following supplemental terms and conditions:

(a) All required final grading and drainage plans, together with all easements made necessary by such plans, must be approved by the Director of Public Utilities prior to the issuance of the building permit.

(b) Storm or surface water shall not be allowed to accumulate on the land. The Owner, at its sole cost and expense, shall provide and maintain at all times adequate facilities for the drainage of storm or surface water from the Property so as not to adversely affect or damage any other property or public streets and the use thereof.

(c) Facilities for the collection of refuse shall be provided in accordance with the requirements of the Director of Public Works. Such facilities shall be located or screened so as not to be visible from adjacent properties and public streets.

(d) Any encroachments existing, proposed on the Plans or contemplated in the future shall require separate authorization and shall be subject to the applicable provisions of the Code of the City of Richmond (2020), as amended, and all future amendments to such laws.

(e) In all other respects, the use of the Property shall be in accordance with the applicable underlying zoning regulations.

§ 5. **General Terms and Conditions.** This special use permit is conditioned on the following general terms and conditions:

(a) No permit implementing this special use permit shall be approved until satisfactory evidence has been presented to the Zoning Administrator that any delinquent real estate taxes applicable to the Property have been paid.

(b) The Owner shall be bound by, shall observe and shall comply with all other laws, ordinances, rules and regulations applicable to the Property, except as otherwise expressly provided in this ordinance.

(c) Words and phrases used in this ordinance shall be interpreted to have the meanings ascribed to them by section 30-1220 of the Code of the City of Richmond (2020), as amended, unless the context clearly indicates that a different meaning is intended.

(d) Notwithstanding any other provision of law, this special use permit is being approved due, in part, to the mitigating effects of each and every condition attached hereto; consequently, if any portion of this ordinance is determined to be invalid for any reason by a final, non-appealable order of any Virginia or federal court of competent jurisdiction, the invalidity shall cause the entire ordinance to be void and of no further effect from the effective date of such order.

(e) The privileges granted by this ordinance may be revoked pursuant to the provisions of sections 30-1050.7 through 30-1050.11 of the Code of the City of Richmond (2020), as

amended, and all future amendments to such laws. Failure to comply with the terms and conditions of this ordinance shall constitute a violation of section 30-1080 of the Code of the City of Richmond (2020), as amended, and all future amendments to such law, or any other applicable laws or regulations.

(f) When the privileges granted by this ordinance terminate and the special use permit granted hereby becomes null and void, whether as a result of the Owner relinquishing this special use permit in a writing addressed to the Director of Planning and Development Review or otherwise, use of the Property shall be governed thereafter by the zoning regulations prescribed for the district in which the Property is then situated.

§ 6. **Implementation.** The Commissioner of Buildings is authorized to issue a building permit substantially in accordance with the Plans for the Special Use subject to the terms and conditions set forth in this ordinance. An application for the building permit shall be made within 1,096 calendar days following the date on which this ordinance becomes effective. If either the application for the building permit is not made within the time period stated in the previous sentence or the building permit terminates under any provision of the Virginia Statewide Building Code, this ordinance and the special use permit granted hereby shall terminate and become null and void.

§ 7. **Effective Date.** This ordinance shall be in force and effect upon adoption.

ATRUE COPY:
TESTE:

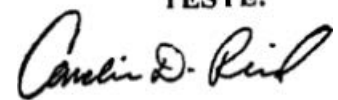

City Clerk

City of Richmond

Intracity Correspondence

O&R Transmittal

DATE: March 26, 2026

TO: The Honorable Members of City Council

THROUGH: The Honorable Dr. Danny Avula, Mayor (by request)
(This in no way reflects a recommendation on behalf of the Mayor)

THROUGH: Odie Donald II, Chief Administrative Officer

THROUGH: Sharon L. Ebert, DCAO for Economic Development and Planning

FROM: Kevin J. Vonck, Director of Planning & Development Review

RE: To authorize the special use of the property known as 310 North 25th Street for the purpose of one two-family attached dwelling and two dwelling units within an accessory structure, upon certain terms and conditions.

ORD. OR RES. No. _____

PURPOSE: The applicant is requesting a special use permit to authorize the construction of a new accessory structure with two dwelling units in the rear of an existing two-family attached dwelling. The property is located in the UB – Urban Business District. The UB District does not permit ground floor dwelling units; the addition of dwelling units would be expanding an existing non-conforming use. Additionally, the proposed accessory structure does not meet rear yard setback requirements for the district. A Special Use Permit is therefore necessary to proceed with this request.

BACKGROUND: The property is located in the Church Hill neighborhood on North 25th Street between East Broad Street and East Marshall Street. The property is currently a 2,078 square foot (0.04 acre) parcel of land improved with a two-story two-family attached dwelling. The property is currently a 13,939 sq. ft. (.07 acre) parcel of land. The City’s Richmond 300 Master Plan designates the future land use for the subject property as Community Mixed-Use, which is defined as a

cluster of medium-density, walkable commercial and residential uses that provide neighborhood services to nearby residential communities and sometimes feature regional attractions.

Intensity: Buildings generally ranging from two to six stories, based on street widths, and depending on the historic context and stepping down in height adjacent to residential areas, as necessary. New buildings that are taller than historical buildings should step back from the build to line after matching the height of the predominant cornice line of the block.

Primary Uses: Retail/office/ personal service, multi-family residential, cultural, and open space.

Secondary Uses: Single-family houses, institutional, and government.

The current zoning for this property is UB – Urban Business District. The area is a mix of residential and commercial uses. The proposed density is 4 units upon 0.04 acres or 100 units per acre.

COMMUNITY ENGAGEMENT: The Church Hill Association of RVA and the Church Hill Central Civic Association were notified of the application; additional community notification will take place after introduction.

STRATEGIC INITIATIVES AND OTHER GOVERNMENTAL: Richmond 300 Master Plan

FISCAL IMPACT: \$400 application fee.

DESIRED EFFECTIVE DATE: Upon adoption

REQUESTED INTRODUCTION DATE: April 27, 2026

CITY COUNCIL PUBLIC HEARING DATE: May 26, 2026

REQUESTED AGENDA: Consent

RECOMMENDED COUNCIL COMMITTEE: Planning Commission May 19, 2026

AFFECTED AGENCIES: Office of Chief Administrative Officer

Law Department (for review of draft ordinance)

RELATIONSHIP TO EXISTING ORD. OR RES.: None

ATTACHMENTS: Draft Ordinance, Authorization from Property Owner, Applicant’s Report, Plans, Survey

STAFF:

Alyson Oliver, Program and Operations Supervisor, Land Use Administration (Room 511) 646-3709

O&R Request

Page 3 of 3

Shaianna Trump, Planner & Secretary to the City Planning Commission, Land Use Administration
(Room 511) 646-7319



CITY OF RICHMOND, VA
Department of Planning and Development Review
Land Use Administration Division
900 East Broad Street, City Hall - Room 511, Richmond, Virginia 23219

AUTHORIZATION FROM PROPERTY OWNER

TO BE COMPLETED BY THE APPLICANT

Applicant must complete ALL items

HOME/SITE ADDRESS: 6203 Lakeside Ave Richmond, APARTMENT NO/SUITE _____

APPLICANT'S NAME: Robert B Jones EMAIL ADDRESS: _____

BUSINESS NAME (IF APPLICABLE): _____

SUBJECT PROPERTY OR PROPERTIES: 310 N 25th St Richmond, Va 23223

APPLICATION REQUESTED

- Plan of Development (New or Amendment)
- Wireless Plan of Development (New or Amendment)
- Special Use Permit (New or Amendment)
- Rezoning or Conditional Rezoning
- Certificate of Appropriateness (Conceptual, Administrative Approval, Final)
- Community Unit Plan (Final, Preliminary, and/or Amendment)
- Subdivision (Preliminary or Final Plat Correction or Extension)

TO BE COMPLETED BY THE AUTHORIZED OWNER

Owner must complete ALL items

Signing this affidavit acknowledges that you, as the owner or lessee of the property, authorize the above applicant to submit the above selected application/s on your behalf.

PROPERTY OWNER: Jeffrey F. Zona, Robert B Jones

PROPERTY OWNER ADDRESS: 6203 Lakeside Ave Richmond, Va 23223

PROPERTY OWNER EMAIL ADDRESS: _____

PROPERTY OWNER PHONE NUMBER: 804-317-9436 Authenticator 804-385-1027

Property Owner Signature: Robert B Jones Jeffrey F Zona 06/23/25

The names, addresses, telephone numbers and signatures of all owners of the property are required. Please attach additional sheets as needed. If a legal representative signs for a property owner, please attach an executed power of attorney.

Applicants Report

To Whom It May Concern,

The special use for 310 N 25th st will be for a two-family attached dwelling with two dwelling units within an accessory structure. The units will be stacked, which fits in perfectly with neighborhood and already existing carriage houses on the street. Each unit will have its own exterior access, and will feature one-bedroom apartments. The ability to provide two additional units to our Richmond residents is a huge value-add

We feel this will aid the Richmond housing shortage and goes with the plan to provide more housing. Church hill is such a highly sought after historic neighborhood, and the ability to add two more housing units would be a great way for us contribute to the neighborhood and the Richmond market.

To Whom It may concern,

I Robert Blake Jones, who is the manager of 312 N 25th st LLC will allow 310 N. 25th st to adjoin a party wall to my structure on 312 N 25th st.

 6-18-25

Robert Blake Jones
Manager 312 N 25th st LLC

I HEREBY CERTIFY THAT THIS PHYSICAL IMPROVEMENT SURVEY,
 TO THE BEST OF MY KNOWLEDGE AND BELIEF, IS CORRECT AND COMPLIES
 WITH THE MINIMUM PROCEDURES AND STANDARDS ESTABLISHED BY THE
 VIRGINIA STATE BOARD OF ARCHITECTS, PROFESSIONAL ENGINEERS,
 LAND SURVEYORS AND CERTIFIED LANDSCAPE ARCHITECTS.
 ALL EASEMENTS MAY NOT BE SHOWN.

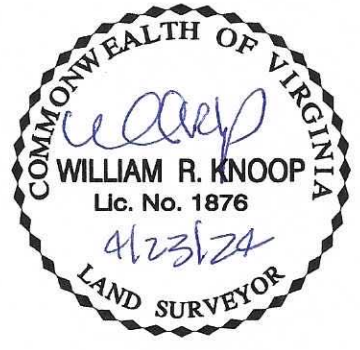
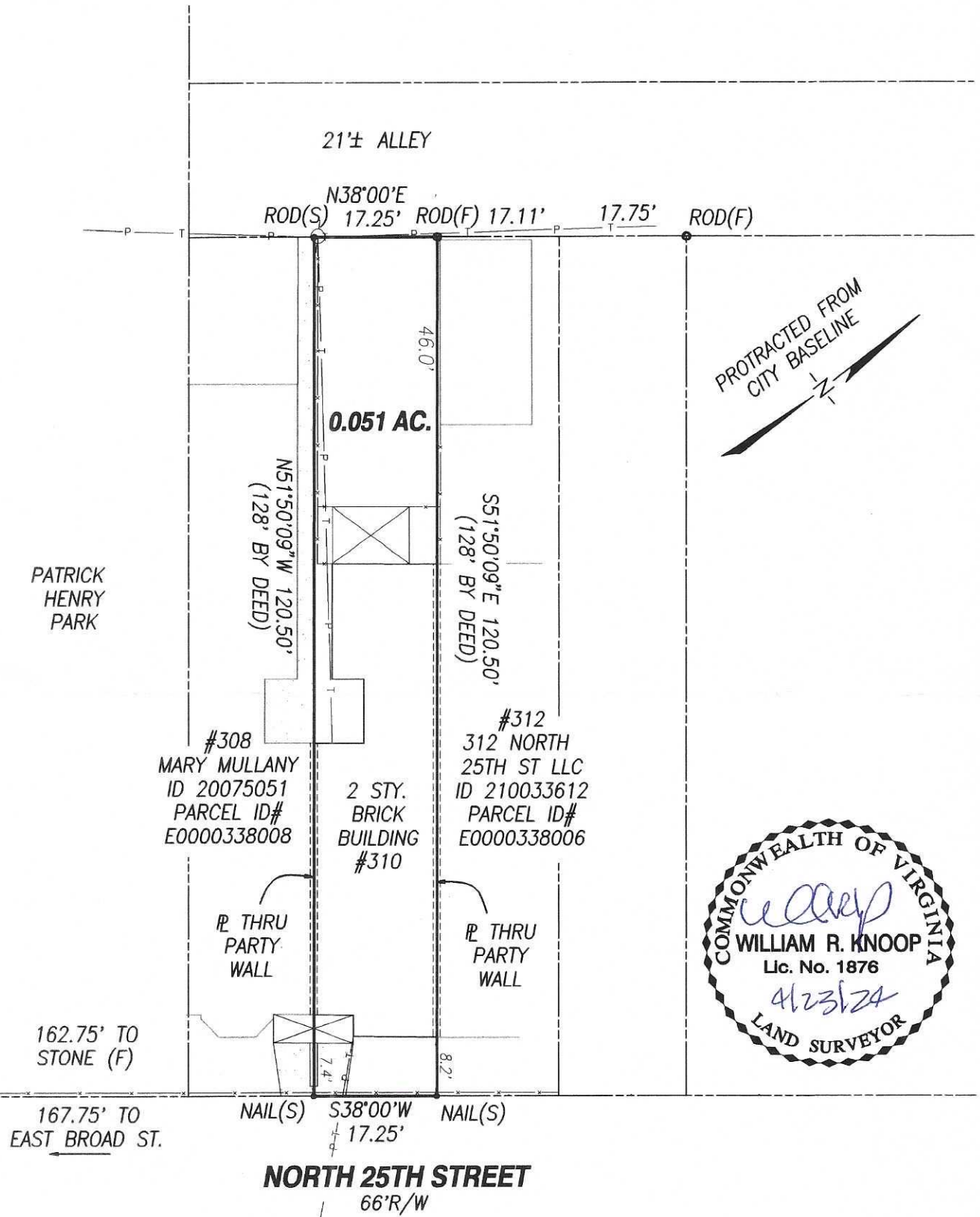

- NOTES:
1. OWNER: BLAKE JONES
 2. ZONING: UB
 3. THIS SURVEY PERFORMED WITHOUT BENEFIT OF A TITLE REPORT.
 4. PROPERTY SHOWN HEREON IS IN FLOOD ZONE "X", A NON HAZARD FLOOD ZONE, FROM FEMA COMMUNITY PANEL 5101290041E, DATED 7/16/2014.
 5. PARCEL ID E0000338007

**PLAT SHOWING
 IMPROVEMENTS ON
 #310 NORTH 25TH STREET
 CITY OF RICHMOND, VIRGINIA**

DATE: APRIL 23, 2024 SCALE: 1" = 20' JN: 8032-0014



Goodfellow, Talbert, Beard, and Associates Inc.
 7104 Mechanicsville Turnpike / P.O. Box 539
 Mechanicsville, Virginia 23111
 (804) 746-7097 Fax (804) 730-7275
ENGINEERING - SURVEYING - PLANNING

NOTES:

1. OWNER: BLAKE JONES
2. ZONING: UB
3. PROPERTY SHOWN HEREON IS IN FLOOD ZONE "X", A NON HAZARD FLOOD ZONE, FROM FEMA COMMUNITY PANEL 5101290041E, DATED 7/16/2014.
4. PARCEL ID E0000338007
5. 1% MINIMUM SLOPE ON ALL UNPAVED AREAS WITHIN THE GRADED AREA.
6. MINIMUM 6" FALL IN 10' AWAY FROM PROPOSED BUILDING.
7. SILT FENCE, LIMITS OF CLEARING AND GRADING, AND CONSTRUCTION AS SHOWN ARE APPROXIMATE AND MAY BE ADJUSTED PER FIELD CONDITIONS OR AS DIRECTED BY THE INSPECTOR.
8. PUBLIC WATER & SANITARY SEWER SERVICE

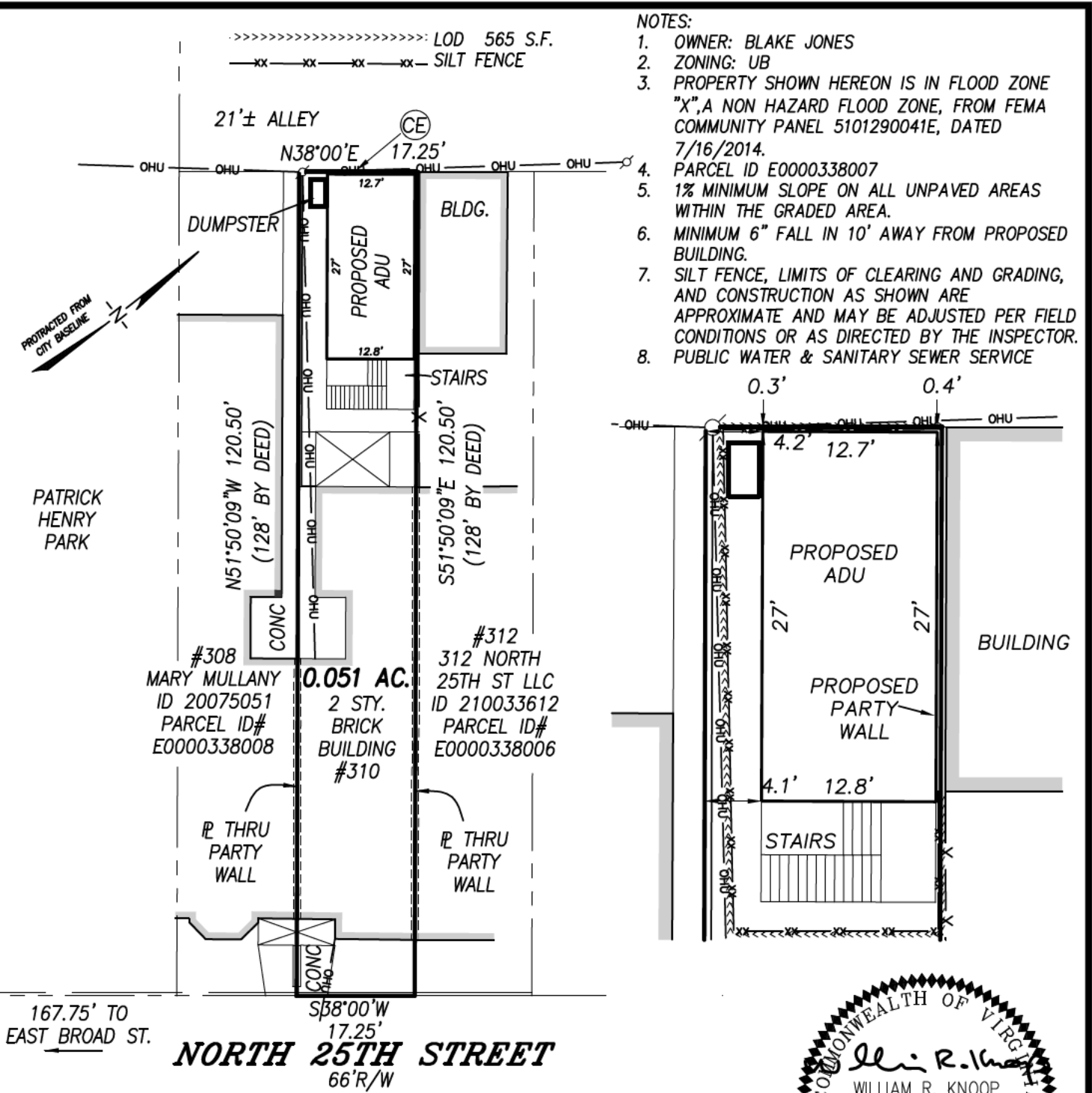

167.75' TO EAST BROAD ST.

NORTH 25TH STREET

S 88°00'W 17.25'
66'R/W

PLAT SHOWING PROPOSED IMPROVEMENTS ON #310 NORTH 25TH STREET CITY OF RICHMOND, VIRGINIA

Date: May 8, 2025 Scale: 1" = 20' JN: 8032-0014



Goodfellow, Galbert, Beard, and Associates Inc
 7104 Mechanicsville Turnpike / P.O. Box 539
 Mechanicsville, Virginia 23111
 (804) 746-7097

ENGINEERING - SURVEYING - PLANNING

FLOOR, CEILING, AND RAFTERS TO BE #2 SOUTHERN YELLOW PINE (SYP) 16' LENGTHS OR LESS. OVER 16' MATERIAL TO BE #2 Hem FIR UNLESS NOTED OTHERWISE (UNO.). HEADER MATERIAL TO BE SYP UNO. STUDS TO BE #2 SPRUCE PINE FIR (SPF) UNO.

EXTERIOR HEADERS IN BRG. WALLS TO BE MIN. DBL. 2 x 8 SYP UNO. HEADERS OVER 4'-0" IN LENGTH TO HAVE DBL. JACKS UNO. INTERIOR HEADERS IN BRG. WALLS TO BE MIN. DBL. 2 x 8 SYP UNO. HEADERS OVER 5'-0" IN LENGTH TO HAVE DBL. JACKS UNO. ALL HEADERS TO CONFORM WITH VRC TABLES R502.5(1) & (2)

CONTINUOUS HEADER OVER MULTIPLE OVERHEAD DOOR OPENINGS REQUIRE ADDITIONAL BRACING FOR HORIZONTAL DEFLECTION AND WIND LOADING OR HEADER PLACED IN CONTACT WITH TOP PLATE SUPPORTING FLOOR ABOVE

NOTED WINDOW HEIGHT PLUS 3" ASSUMED MIN. ROUGH OPENING

NOTED WINDOW WIDTH PLUS 2" ASSUMED MIN. ROUGH OPENING

MINIMUM WINDOW SIZE BASED ON NOTED OPENING

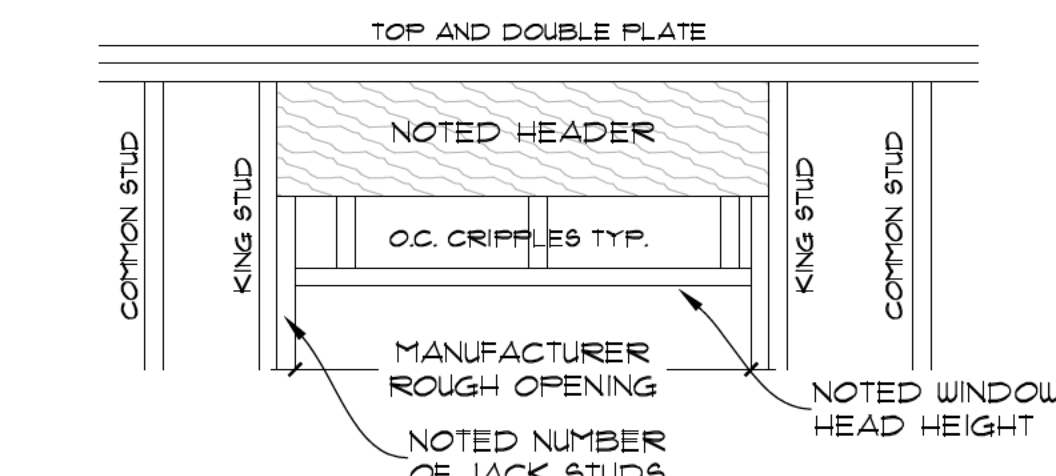
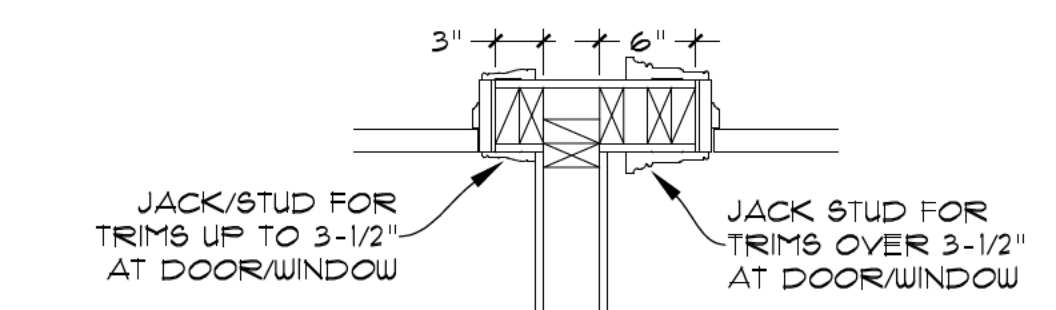

NOT FOR CONSTRUCTION

Lot =
Blk =
Sec =

RICHMOND
310 N 25TH STREET
23223
JOB #:
24-013A

2021 VRC
FIRST FLOOR PLAN

JONES
RESIDENCE

A2

LEGEND:
 ☒ DENOTES LOAD PATH TO BEAM OR FOUNDATION
 - (3) STUD POST, NOTED MANUFACTURER COLUMN, SOLID BLOCKING, OR GROUT CMU UNLESS NOTED OTHERWISE (UNO.)
 - MIN. 4-1/2" (3 STUD MIN) BRG ASSUMED AT ALL LVL.
 - TRIPLE LVL. MINIMUM (4) STUD POST AT BEARING
 - QUAD LVL. MINIMUM (5) STUD POST AT BEARING
 ☒ DENOTES POINT FROM ABOVE
 INTERIOR BRG WALLS INDICATED THUSLY:
 DOUBLE JOISTS WALLS PARALLEL TO F.J.:
 N.B.F. = BEARING ON WALL PLATE NOT ALLOWED. MUST BEAR ON POST
 HEADER SIZE: (2) 2 x 8 SYP HDR (1U)
 NO. OF JACKS: MATERIAL

344 sqft -1st Floor Living
344 sqft -2nd Floor Living

SCALE: 1/4" = 1'-0"

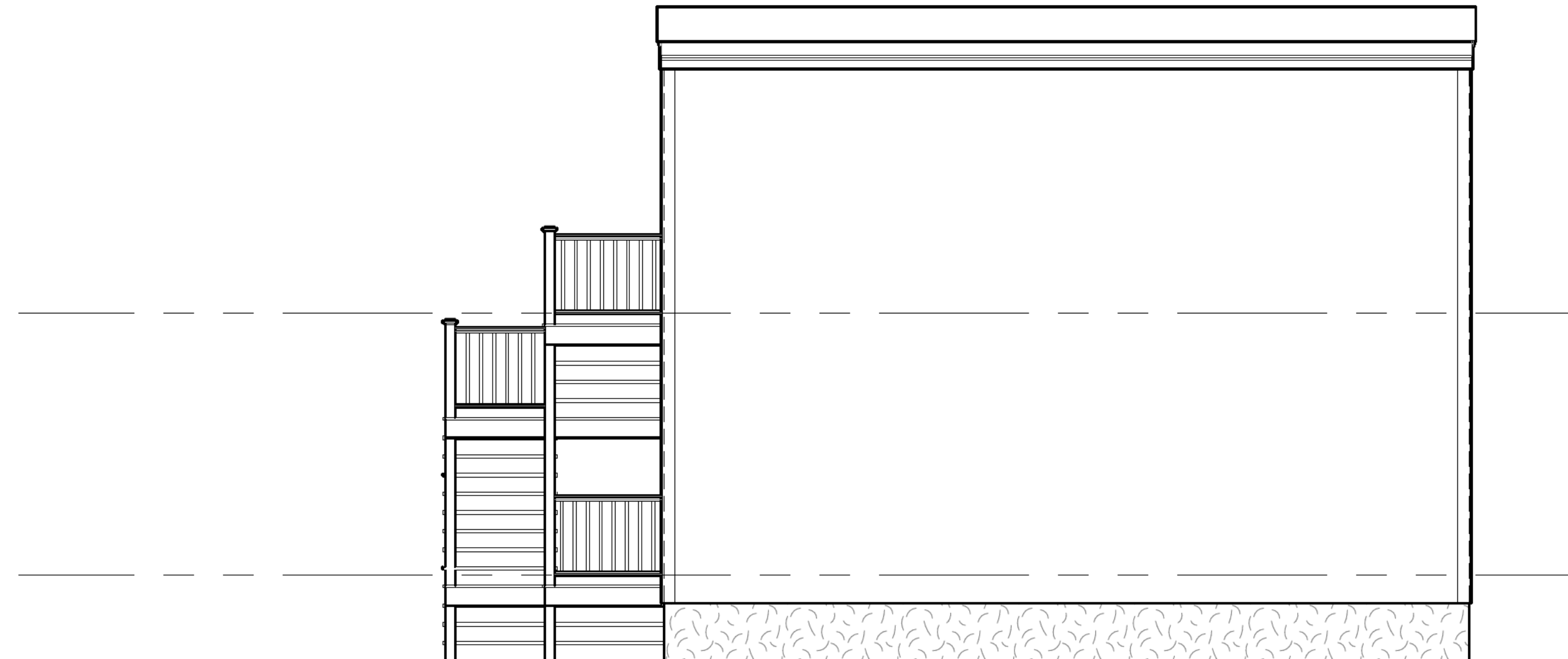
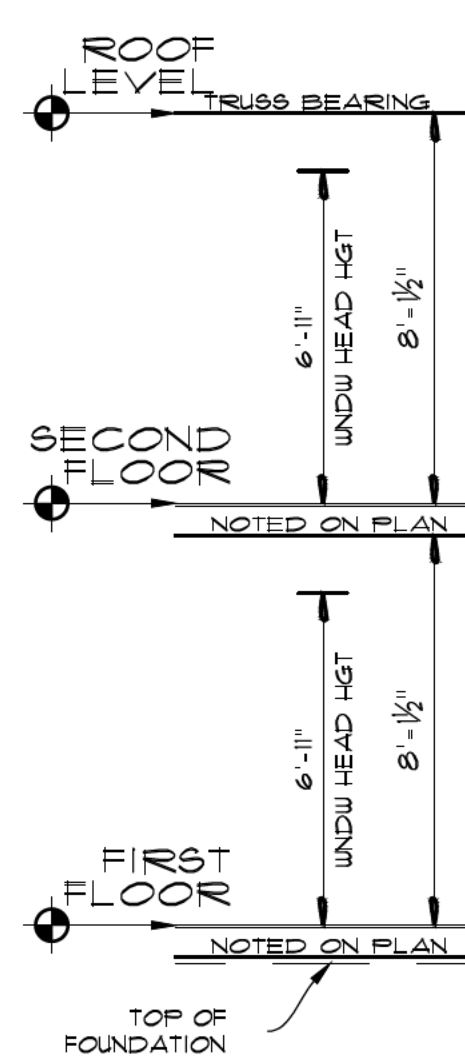

ELEVATION: RIGHT

Scale: 1/4" = 1'-0"

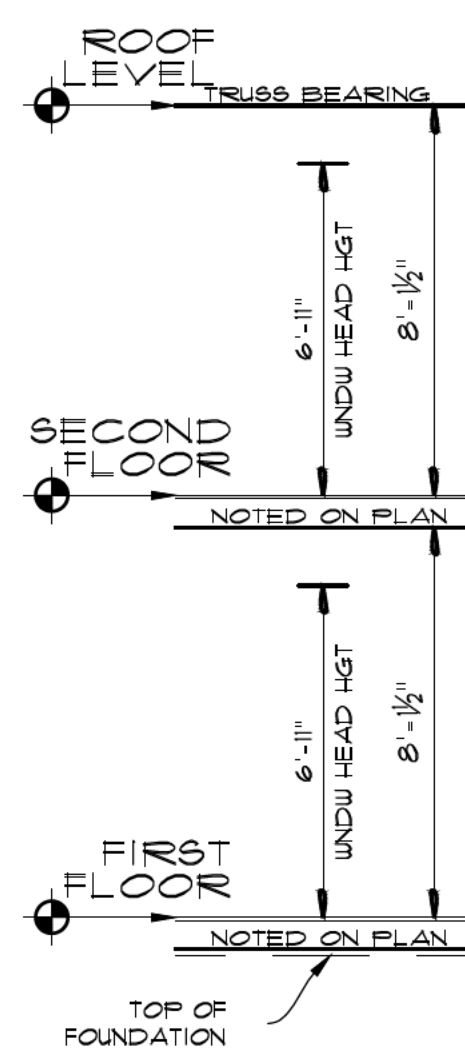

ELEVATION: REAR

Scale: 1/4" = 1'-0"

ELEVATION: LEFT

Scale: 1/4" = 1'-0"

ELEVATION: FRONT

Scale: 1/4" = 1'-0"

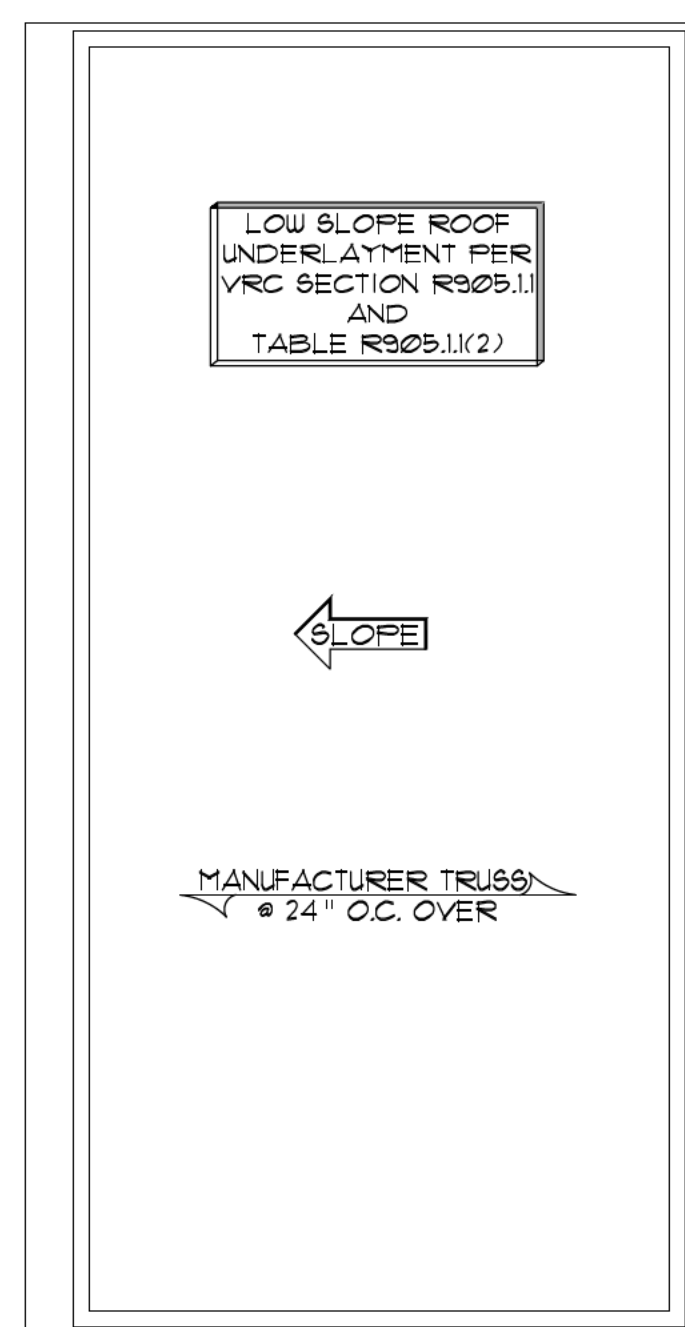

PLAN: ROOF

Scale: 1/4" = 1'-0"

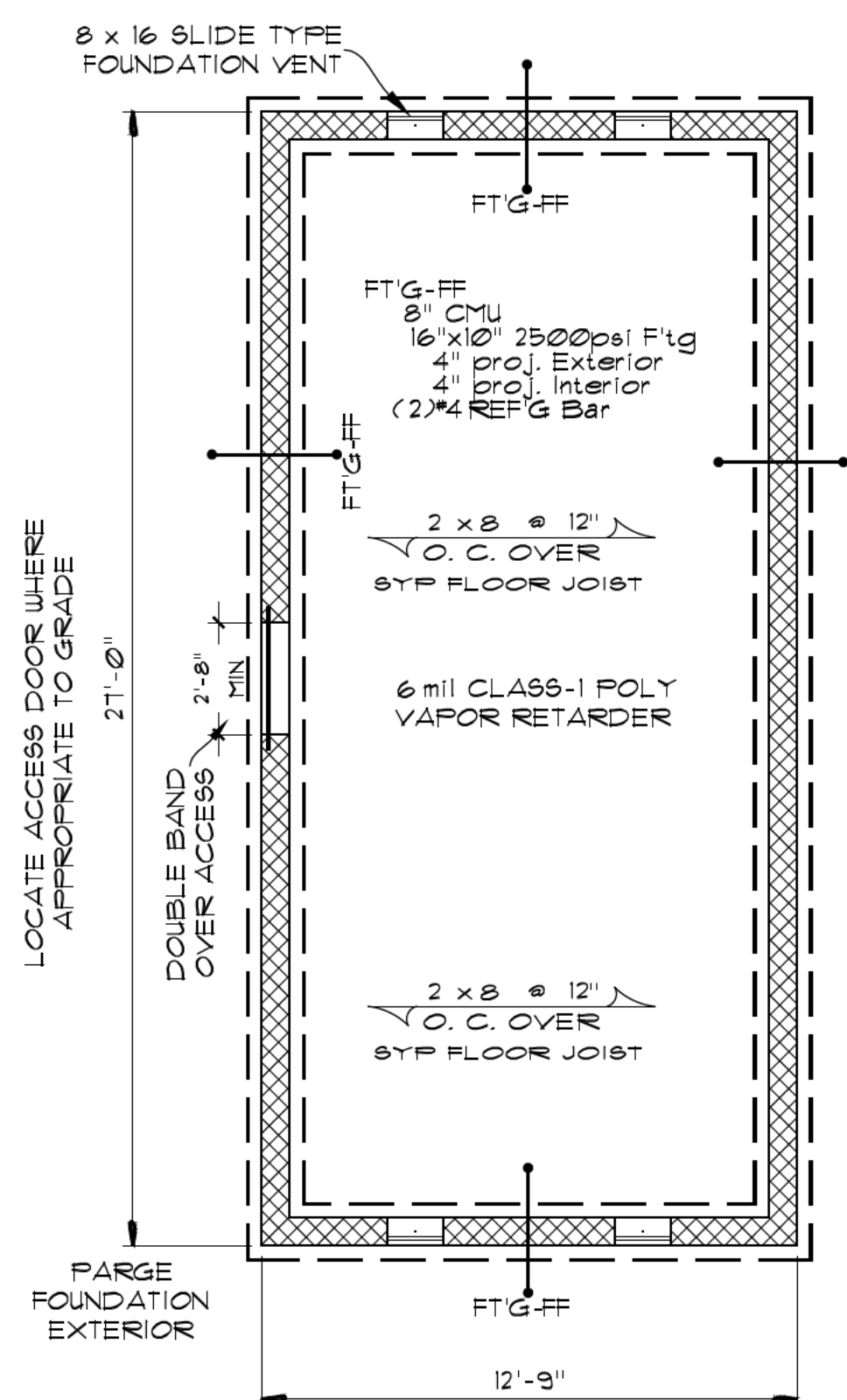

PLAN: FOUND,

Scale: 1/4" = 1'-0"

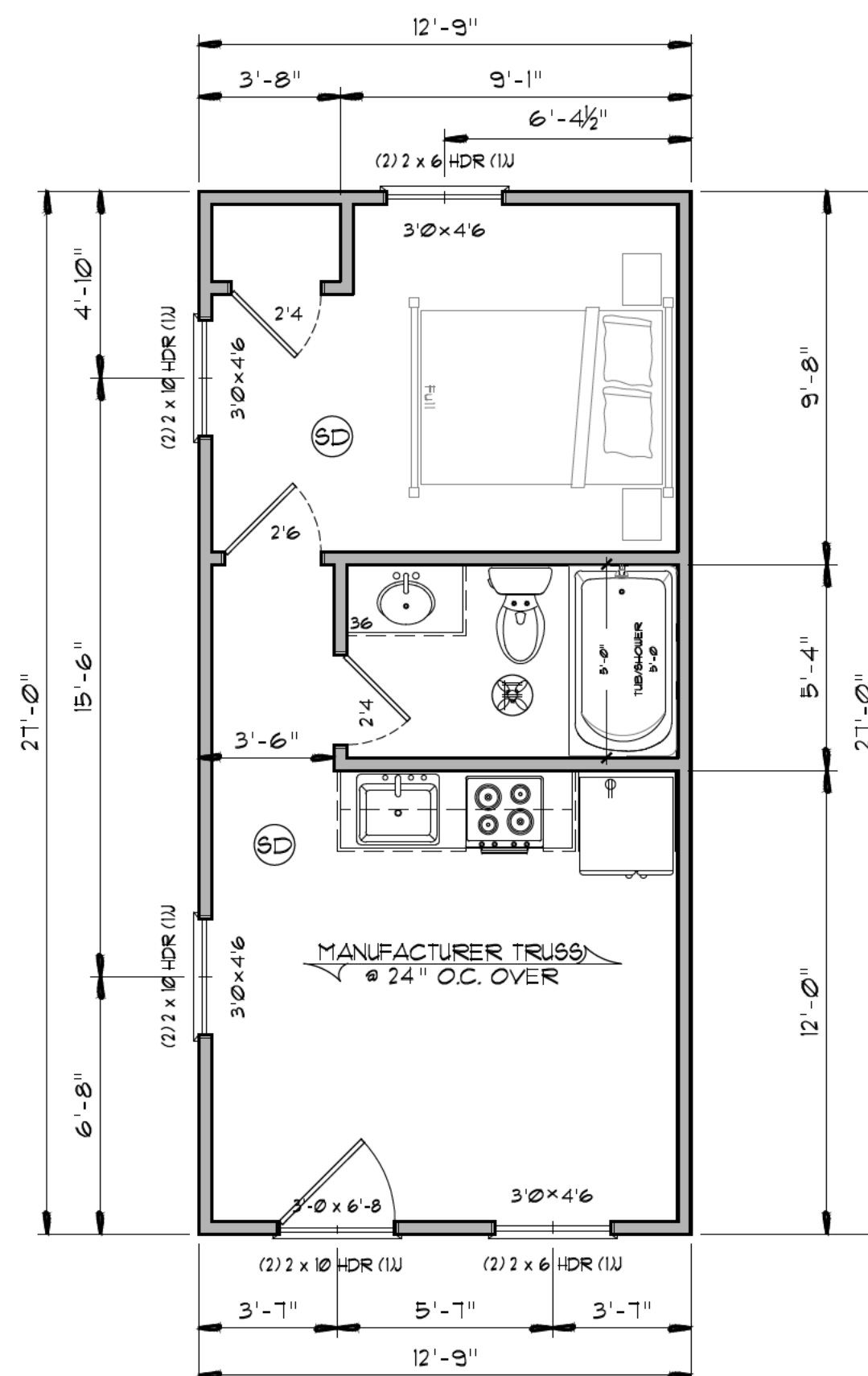

PLAN: 2ND FLOOR

Scale: 1/4" = 1'-0"

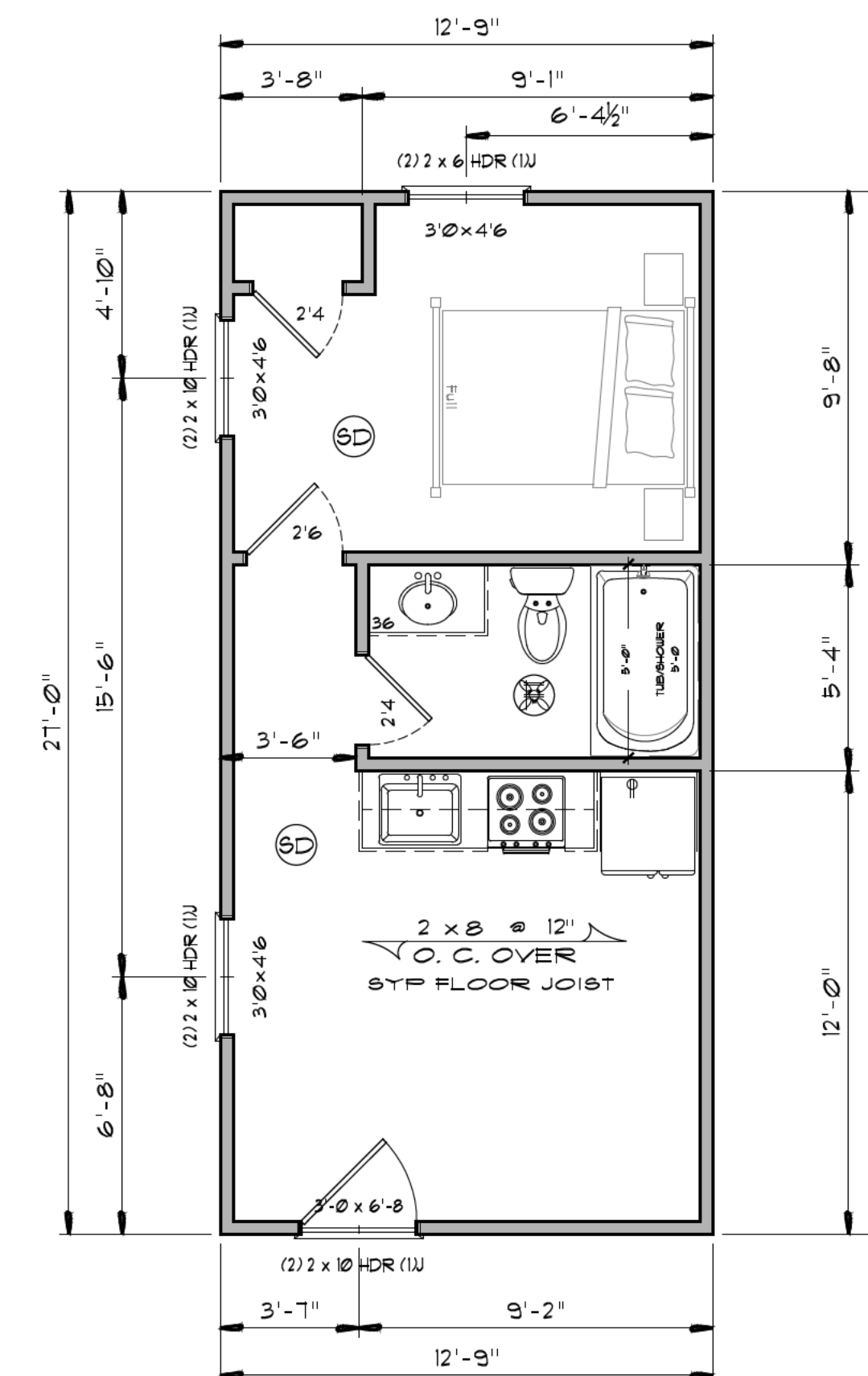

PLAN: 1st FLOOR

Scale: 1/4" = 1'-0"

BUILDER OR BUILDERS AGENT TO NOTIFY DESIGNER OF ANY PLAN DEFICIENCIES PRIOR TO CONSTRUCTION.



City of Richmond
Commission of Architectural Review



December 1, 2025

Blake Jones
6203 Lakeside Avenue
Richmond, VA 23228

Re: 310 N 25th Street
Application No. COA-175460-2025

Dear Applicant:

At the 11/25/2025 meeting of the Commission of Architectural Review, the review of your application for a Certificate of Appropriateness resulted in the following action: Approved with conditions. Specifically, The Commission approved this application for the reasons stated in the staff report provided the following conditions are met:

- Revise the ADU foundation to a parged finish consistent with district precedent; and
- Use 1-over-1 double-hung windows for the new construction and submit full window specifications, materials, and dimensions for staff review and approval; and
- Add vertically aligned, full-size windows on the rear alley-facing elevation and submit the revised rear elevation for staff review; and
- Submit the final wood railing profile for staff approval; and
- Confirm lap siding color for review and approval; and
- Confirm material for the property-line wall. Clarify whether the ADU will be attached or free-standing; if the siting or wall configuration changes, a revised application must be submitted to the CAR; and
- Implement all necessary protection measures to safeguard the adjacent historic masonry during construction, and ensure that appropriate mitigation practices are used to prevent damage to historic fabric; and
- Any changes to the historic masonry wall at 312 N 25th Street must be submitted in a separate COA application; and
- Any changes that affect the design, either by a code requirement or by the addition of a parapet, be submitted for chair and vice-chair approval.

You, or any aggrieved party, have the right to appeal a decision of the Commission of Architectural Review to City Council as specified in Section 30.930 of the Richmond City Code. A petition stating reasons for the appeal must be filed with the City Clerk within 15 days of this meeting.

If you have any questions, please contact Alex Dandridge, CAR Secretary at (804) 646-6569 or by e-mail at alex.dandridge@rva.gov.

Sincerely,

Alex Dandridge
Secretary, Commission of Architectural Review (CAR)