



COMMISSION OF ARCHITECTURAL REVIEW

APPLICATION FOR CERTIFICATE OF APPROPRIATENESS

PROPERTY (location of work)

Address 2608 East Grace Street

Historic district Church Hill North

Date/time rec'd: 1/9/18 12:30

Rec'd by: C. J. J. J.

Application #: COA-029595-2018

Hearing date: 2/27/18

APPLICANT INFORMATION

Name Chris deTreville

Phone 8043341160

Company OBSIDIAN, INC

Email cdetreville@obsidian.pro

Mailing Address 515 N. 22nd Street
Richmond, Virginia 23223

Applicant Type: Owner Agent

Lessee Architect Contractor

Other (please specify): Structural Engineer

OWNER INFORMATION (if different from above)

Name Robert and Teresa Fairbanks

Company _____

Mailing Address 2608 East Grace Street
Richmond, Virginia, 23223

Phone 1.919.896.3664

Email tfrbnks@gmail.com

PROJECT INFORMATION

Review Type: Conceptual Review Final Review

Project Type: Alteration Demolition

New Construction
(Conceptual Review Required)

Project Description: (attach additional sheets if needed)

Construct new garage

ECE VED

JAN 09 2018

ACKNOWLEDGEMENT OF RESPONSIBILITY

Compliance: If granted, you agree to comply with all conditions of the COA. Revisions to approved work require staff review and may require a new application and CAR approval. Failure to comply with the COA may result in project delays or legal action. The COA is valid for one (1) year and may be extended for an additional year, upon written request.

Requirements: A complete application includes all applicable information requested on checklists to provide a complete and accurate description of existing and proposed conditions. Preliminary review meeting or site visit with staff may be necessary to process the application. Owner contact information and signature is required. Late or incomplete applications will not be considered.

Zoning Requirements: Prior to CAR review, it is the responsibility of the applicant to determine if zoning approval is required and application materials should be prepared in compliance with zoning.

Signature of owner

AGENT

Date 1/9/18

2608 East Grace Street Garage CAR Application

Owner

Robert & Teresa Fairbanks
2608 East Grace Street
Richmond, VA 23223

Engineer

Obsidian, Inc.
Charles R. Field, P.E.
515 North 22nd Street
Richmond, VA 23223
804.647.1589
obsidianrva@gmail.com

Table of Contents

CAR 1 Title Sheet
CAR 2 Elevations
CAR 3 Site Plan

Property Information

Parcel ID E0000438021
Zoning R-6
Use Residential
Lot Coverage <55%

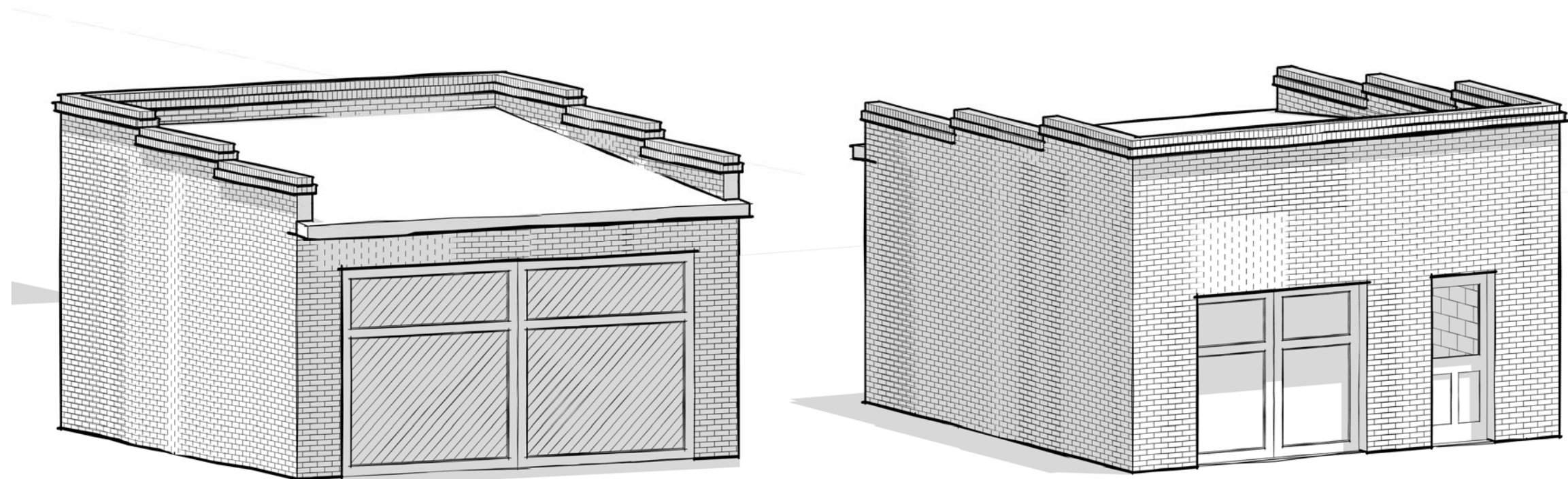

Print plans at 11" x 17",

Rev.	Date	Description

Obsidian, Inc.
515 North 22nd Street
Richmond, VA 23223
804.647.1589
obsidianrva@gmail.com

Title Sheet
2608 East Grace Street - Garage Plans
Robert & Teresa Fairbanks
February 2, 2018
CAR 1

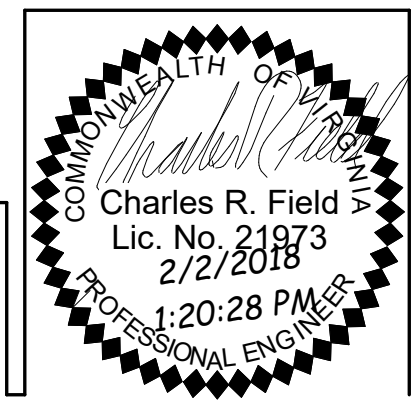

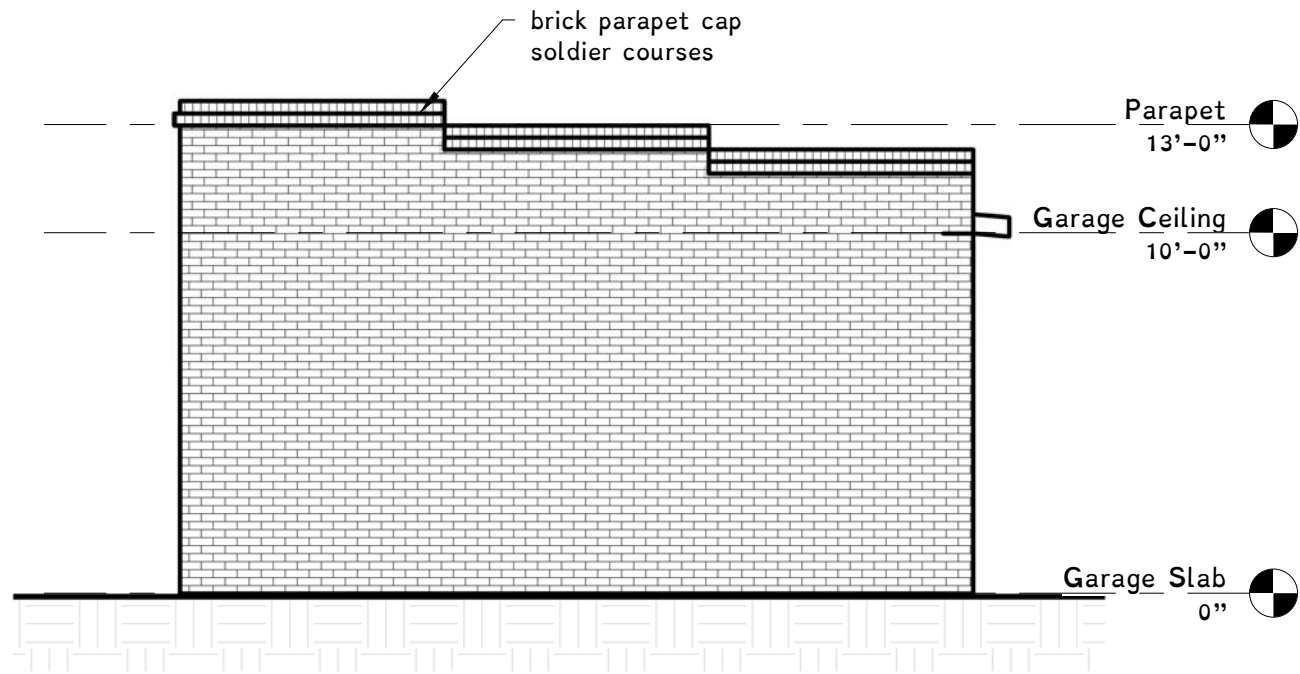

1 Proposed East
3/16" = 1'-0"

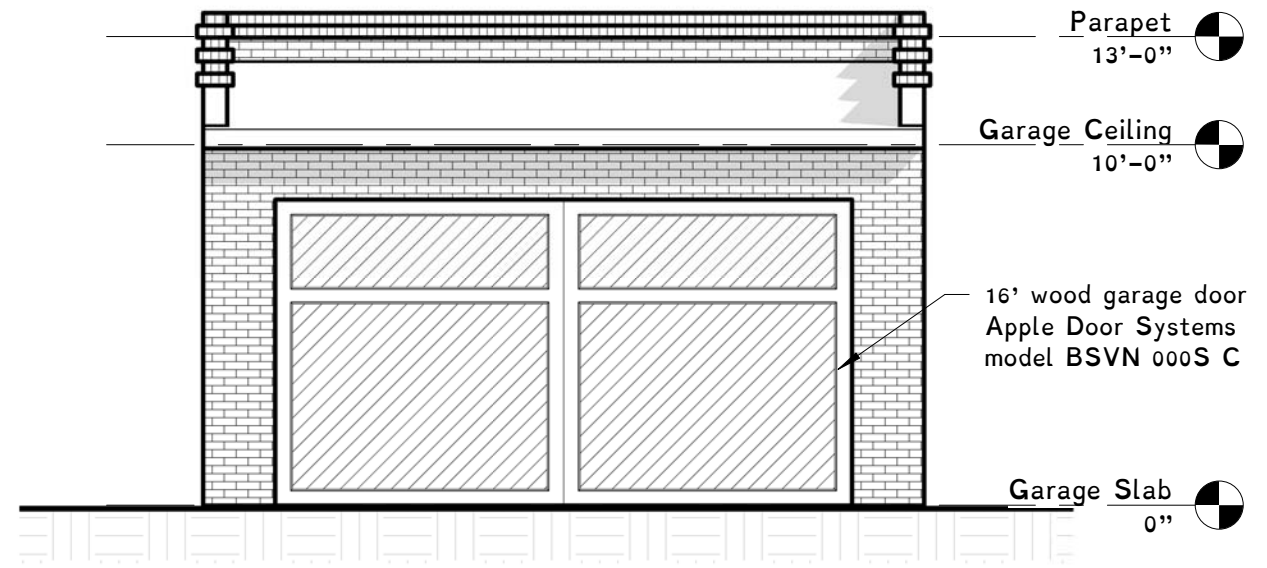

2 Proposed North
3/16" = 1'-0"

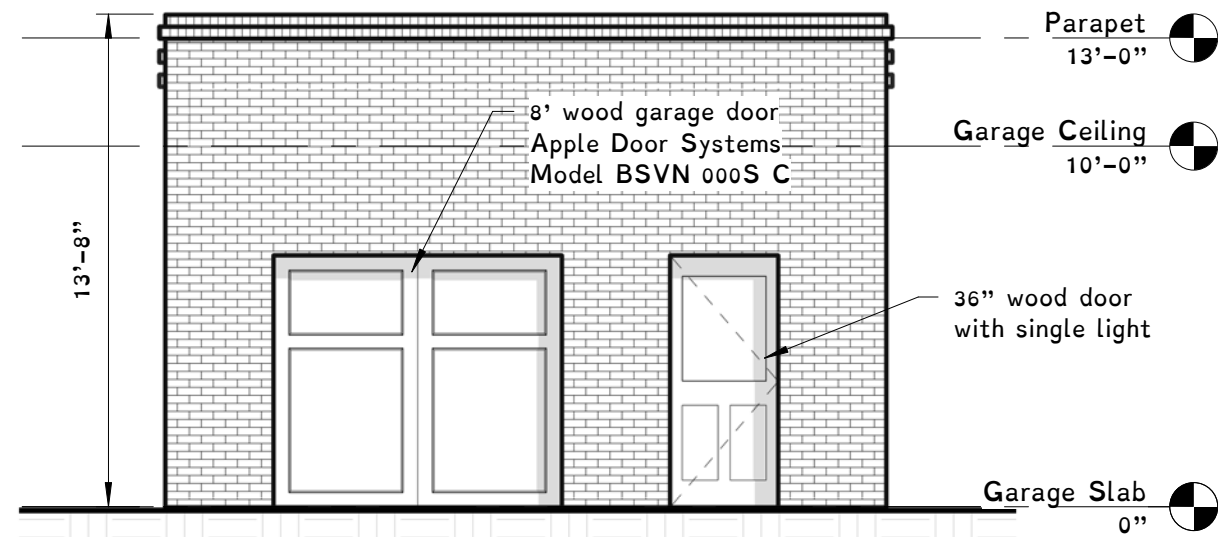

3 Proposed South
3/16" = 1'-0"

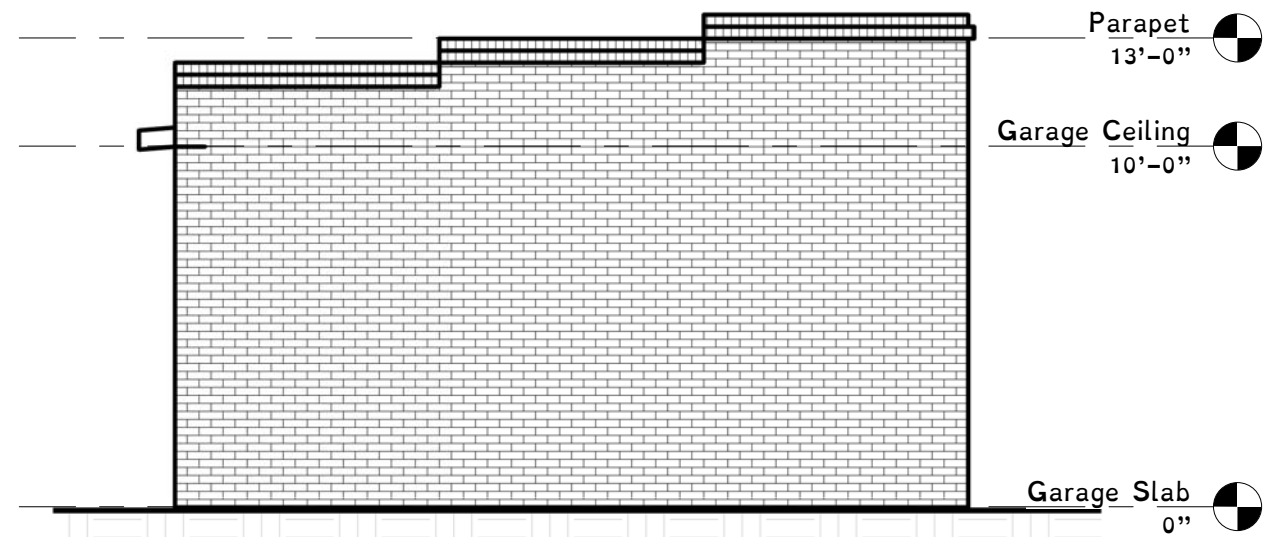

4 Proposed West
3/16" = 1'-0"

Print plans at 11" x 17",

Rev.	Date	Description

Obsidian, Inc.
515 North 22nd Street
Richmond, VA 23223
804.647.1589
obsidianrva@gmail.com

Elevations
2608 East Grace Street - Garage Plans
Robert & Teresa Fairbanks
February 2, 2018

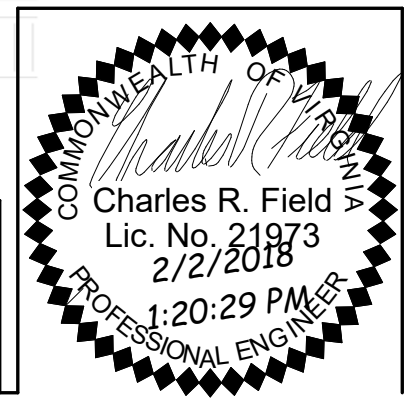

CAR 2

Print plans at 11" x 17",

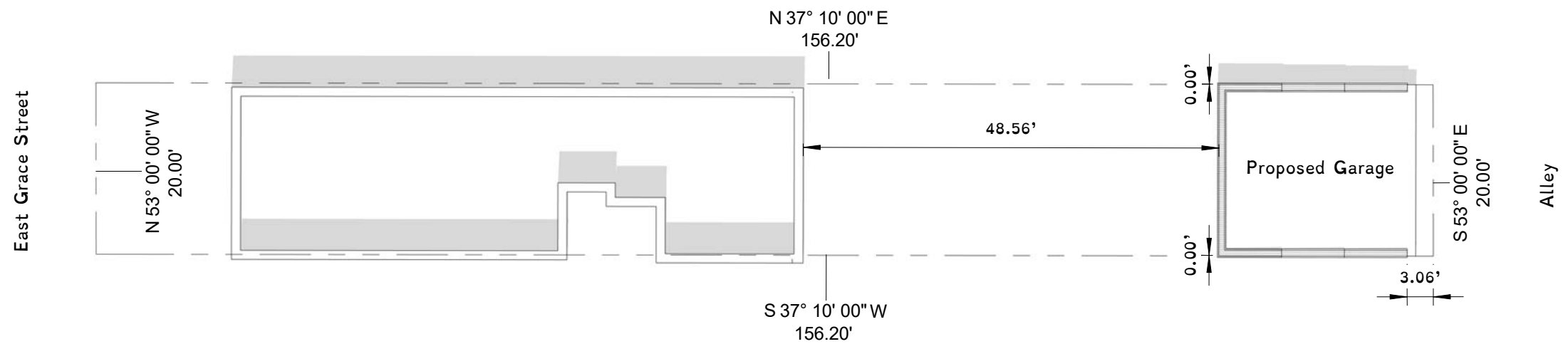

1 Site Plan
1/16" = 1'-0"

Rev.	Date	Description

Obsidian, Inc.
515 North 22nd Street
Richmond, VA 23223
804.647.1589
obsidianrva@gmail.com

Site Plan
2608 East Grace Street - Garage Plans
Robert & Teresa Fairbanks
February 2, 2018
CAR 3

