



Commission of Architectural Review SUBMISSION APPLICATION

City of Richmond, Room 510 – City Hall
900 East Broad Street, Richmond, Virginia 23219
PHONE: (804) 646-6335 FAX: (804) 646-5789

12 COPIES OF SUPPORTING DOCUMENTATION ARE REQUIRED FOR PROCESSING YOUR SUBMISSION

LOCATION OF WORK: 2238 West Grace Street DATE: 05/25/2015

OWNER'S NAME: Edward Price TEL NO.: 540-353-3721

AND ADDRESS: 2238 West Grace Street EMAIL: ed.price90@yahoo.com

CITY, STATE AND ZIPCODE: Richmond, VA 23220

ARCHITECT/CONTRACTOR'S NAME: Owner built TEL. NO.: _____

AND ADDRESS: _____ EMAIL: _____

CITY, STATE AND ZIPCODE: _____

Would you like to receive your staff report via email? Yes No

REQUEST FOR CONCEPTUAL REVIEW

I hereby request Conceptual Review under the provisions of Chapter 114, Article IX, Division 4, Section 114-930.6(d) of the Richmond City Code for the proposal outlined below in accordance with materials accompanying this application. I understand that conceptual review is advisory only.

APPLICATION FOR CERTIFICATE OF APPROPRIATENESS

I hereby make application for the issuance of a certificate under the provisions of Chapter 114, Article IX, Division 4 (Old and Historic Districts) of the Richmond City Code for the proposal outlined below in accordance with plans and specifications accompanying this application.

DETAILED DESCRIPTION OF PROPOSED WORK (Required):

STATE HOW THE DESIGN REVIEW GUIDELINES INFORM THE DESIGN OF THE WORK

PROPOSED. (Include additional sheets of description if necessary, and 12 copies of artwork helpful in describing the project. The 12 copies are not required if the project is being reviewed for an administrative approval. See instruction sheet for requirements.)

This is a replacement of an upper and lower deck. The current old decking was designed for when the property was 3 units. The back deck has steps upstairs to old units that no longer exist as the property is not single family. This will keep the same basic footprint with no steps and conforming to code by being over 3 feet from closest building. This will also move the decking further from neighbors windows and doors than they are currently. The goal is to bring the decking back in line with single family and not multi family. Please see other information with this application.

Signature of Owner or Authorized Agent: X 

Name of Owner or Authorized Agent (please print legibly): Edward Price

(Space below for staff use only)

Received by Commission Secretary

DATE RECEIVED

3:03 pm

APPLICATION NO. _____

SCHEDULED FOR _____

Note: CAR reviews all applications on a case-by-case basis.

MAY 29 2015

To the Commission of Architectural Review

Description of work under review:

We are asking to replace the existing decks as seen in the enclosed pictures which once were used for the house when it was three apartments. As this house has been restored to a single family dwelling these steps in the rear are no longer necessary nor wanted. The demolition and reconstruction of the new decking would cover almost the exact same footprint as the current structure minus the steps. The new decking would conform to code by being 43" from the adjacent structure and over 10 feet from the closest door or window of the nearest neighbor. In keeping up with the historical nature of the home the removal of these old decks and steps will be a welcome site to an improving neighborhood.









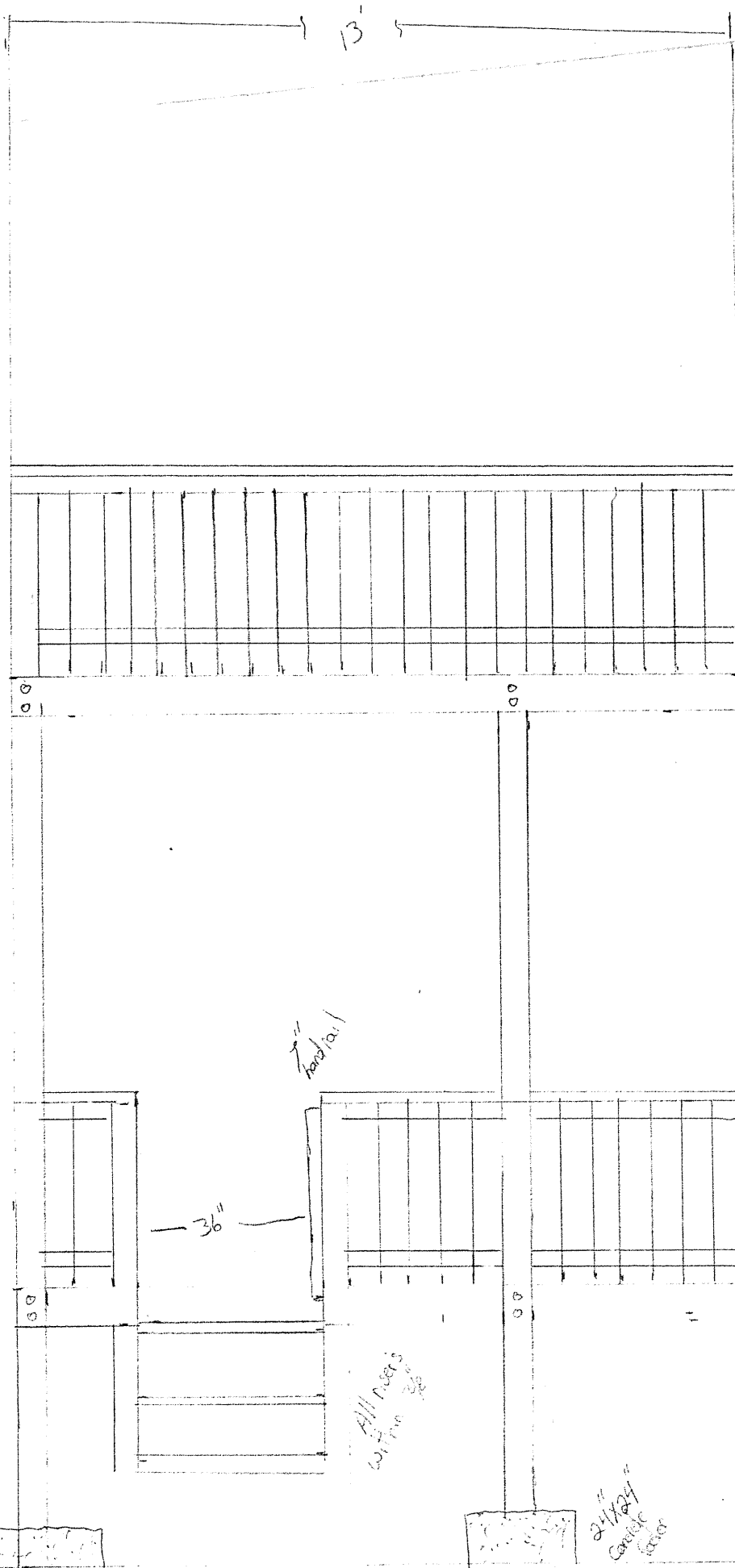

2x8 outer boards
 2x8 Joist 16 on d
 5/4 decking

36"
 Grand rails
 w/ balusters
 4" on d

Hand rail

36"

All pieces
 within

2x4x4
 Concrete
 pier

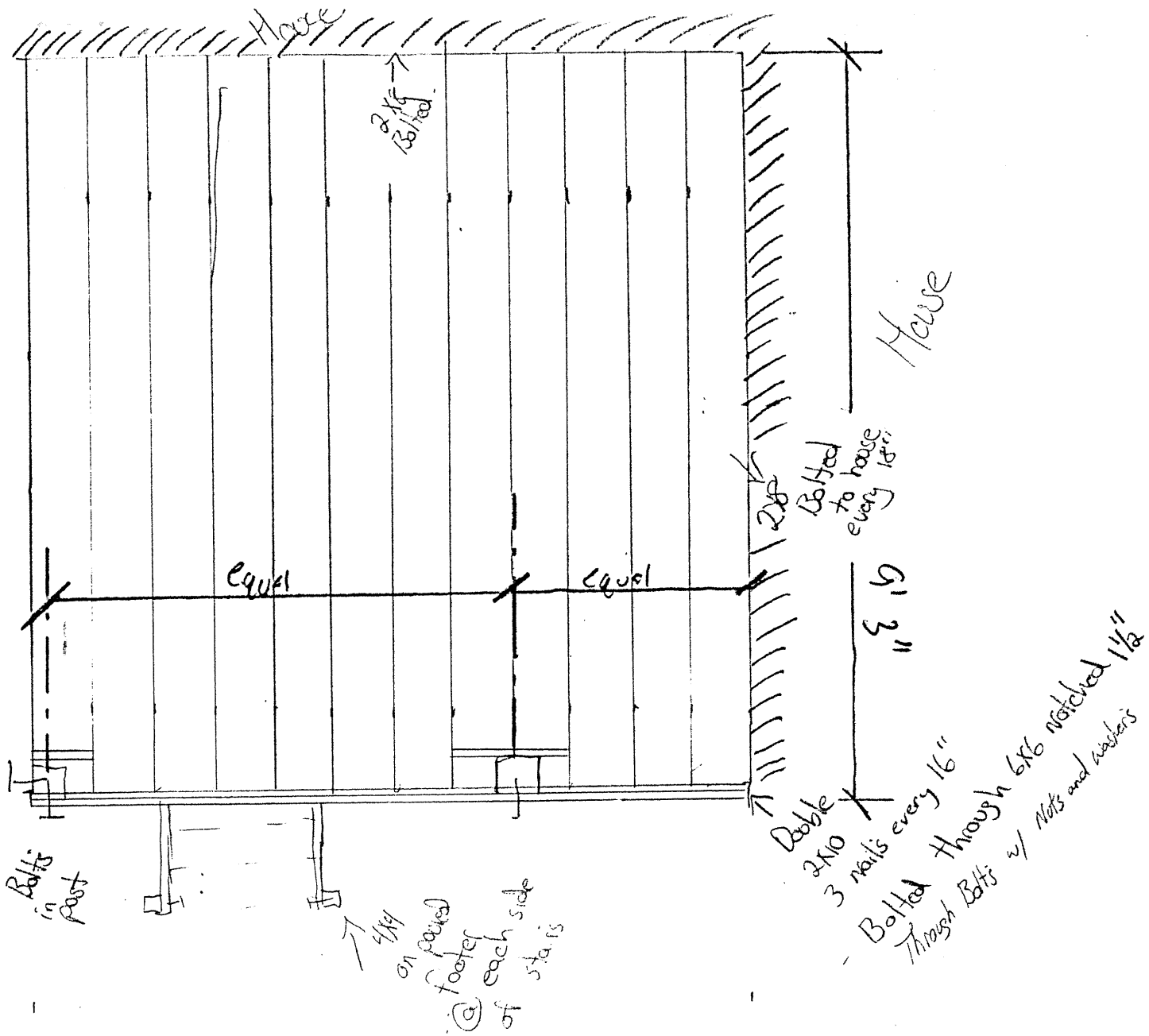

Joist every 16" on center
with Joist hangers
on each end

not to scale



NEVER STOP
IMPROVING

DECK DESIGNER

powered by  DIY Technologies

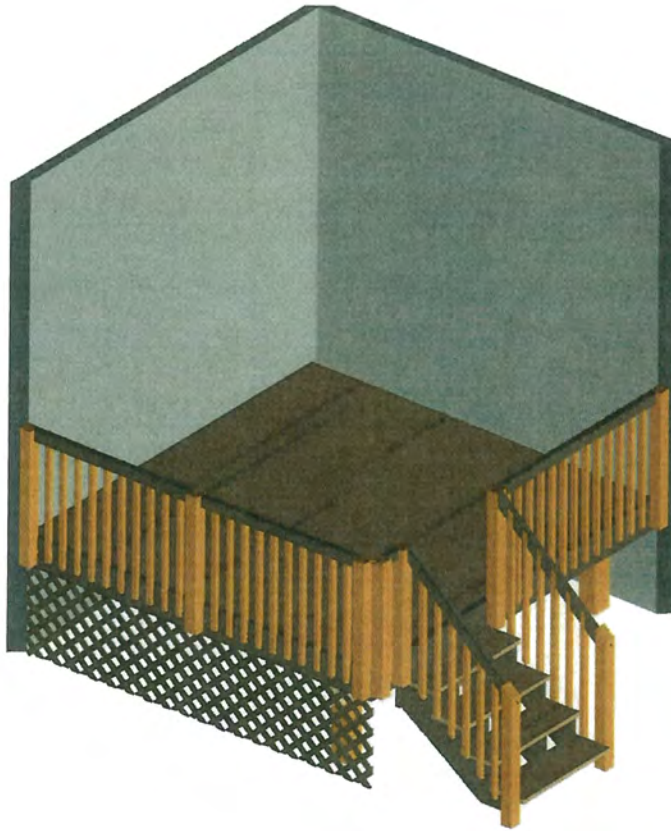

Lowe's Deck Design

2238 W. Grace Street Bottom Deck

Print this document and take it to the Doors and Windows desk or Commercial Sales desk
at your local Lowe's store.

One of our associates will help you find the materials you need.

Your Deck Design's Project ID is:
829050599

Deck layout diagram

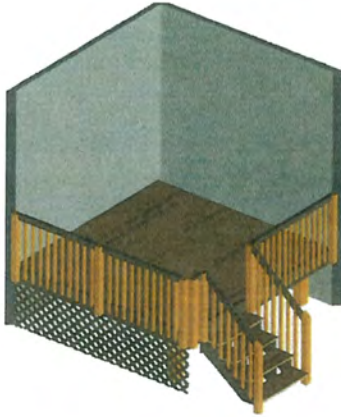

Top view without planks



Bottom view with planks

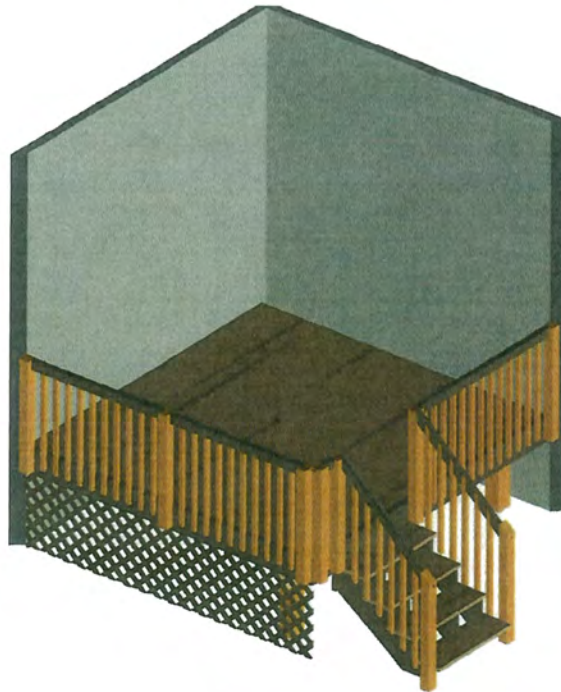

Top view with planks

Deck Part Identification

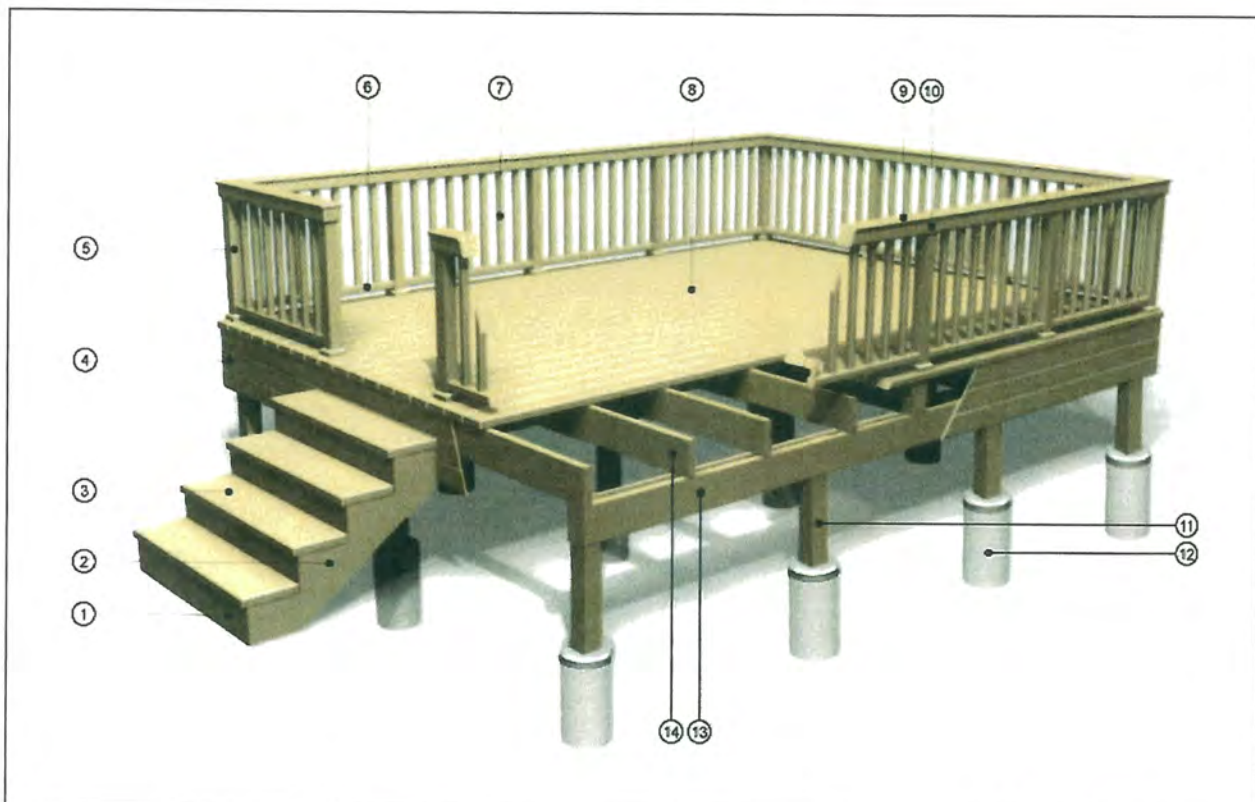

1. Riser	6. Bottom Rail	11. Post	Major Deck Components NOTE: Not to scale ©2015 DIY Technologies
2. Stringer	7. Baluster	12. Post Footer	
3. Tread	8. Decking	13. Beam	
4. Fascia	9. Rail Cap	14. Joist	
5. Rail Post	10. Top Rail		

Baluster	The vertical pieces of a railing spaced at regular intervals between posts.
Beam	A horizontal framing piece, which rests on posts and supports joists.
Decking	The boards used to make the walking surface of the deck.
Joist	A horizontal frame piece that supports the decking and spreads the weight over the beams.
Ledger	A horizontal strip that connects the deck to the house.
Post Footer	Concrete filled hole that the post is attached to.
Post	A vertical framing piece, used to support a beam or joist.
Riser	A board attached to the vertical cut surface of a stair stringer.
Stringer	The diagonal board used to support treads and risers on a stairway.
Tread	The horizontal surface of a stair.
Bottom Rail	The lower horizontal piece that connects rail posts and supports balusters.
Top Rail	The upper horizontal piece that connects rail posts and supports balusters.
Rail Cap	The top horizontal trim on railing.
Rail Post	The vertical post connected to the deck framing that supports the railing.

Structural Connector Hardware Guide

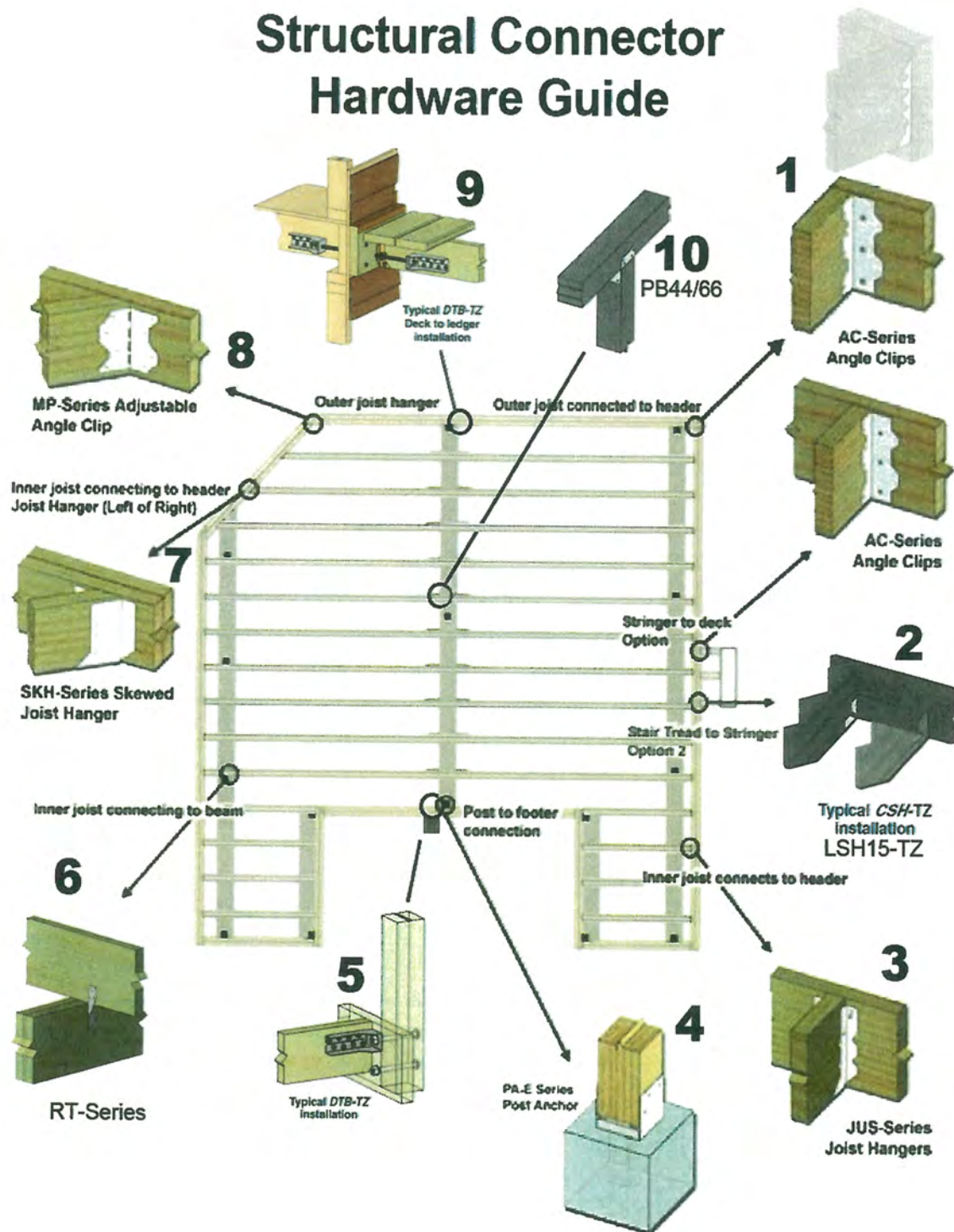



INSTALLATION CHECKLIST

General legal requirements

Check title restrictions and easements, building codes and zoning by-laws to make sure your deck design complies.

Obtain any required permits or zoning variances.

Check with local utility companies to make sure deck footings and construction will not disturb or obstruct access to piping or wiring.

Deck function

While planning your deck, determine how it will be used.

Your climate

While planning your deck, consider local weather.

Take advantage of good views.

Install ledger

Install ledger to anchor deck to house.

Ledger placement determines the deck floor level, normally 2-4" below floor line.

If unsure about attaching a ledger board, consult a professional.

Use batterboards and mason's string to mark off deck area and locate footing.

Square with string

Attach string to ledger and/or batterboards.

Batterboards go just outside perimeter corners of the deck.

Use the 3-4-5 method to get a 90 degree angle in one corner.

Footing requirements

Footing/posthole depth and location is dictated by local codes and by-laws.

INSTALLATION CHECKLIST

Attach beams to posts

Determine the desired deck floor height on the posts.

Determine height for securing the top of the beam to the post.

Attach joists

Joists are attached to ledger board with joist hangers or by toenailing.

Determine where blocking will go and snap a chalk line, but make sure to stagger pieces for ease of nailing.

Lay decking

Attach boards "bark side up" to minimize cupping and warping.

The deck boards can be trimmed after they are installed.

Railings

Railings must be firmly attached to the framing members of the deck.

Check local codes and by-laws for requirements on railings.

Stairs

Check local codes and by-law requirements on stairs.

Measure the rise and run of the stairs.

Multi-level decks

When planning a multi-level deck, for aesthetics make one deck larger than the other.

INSTALLATION CHECKLIST

Post bracing

Brace posts as dictated by local codes and by-laws.

BRACE AT JOIST

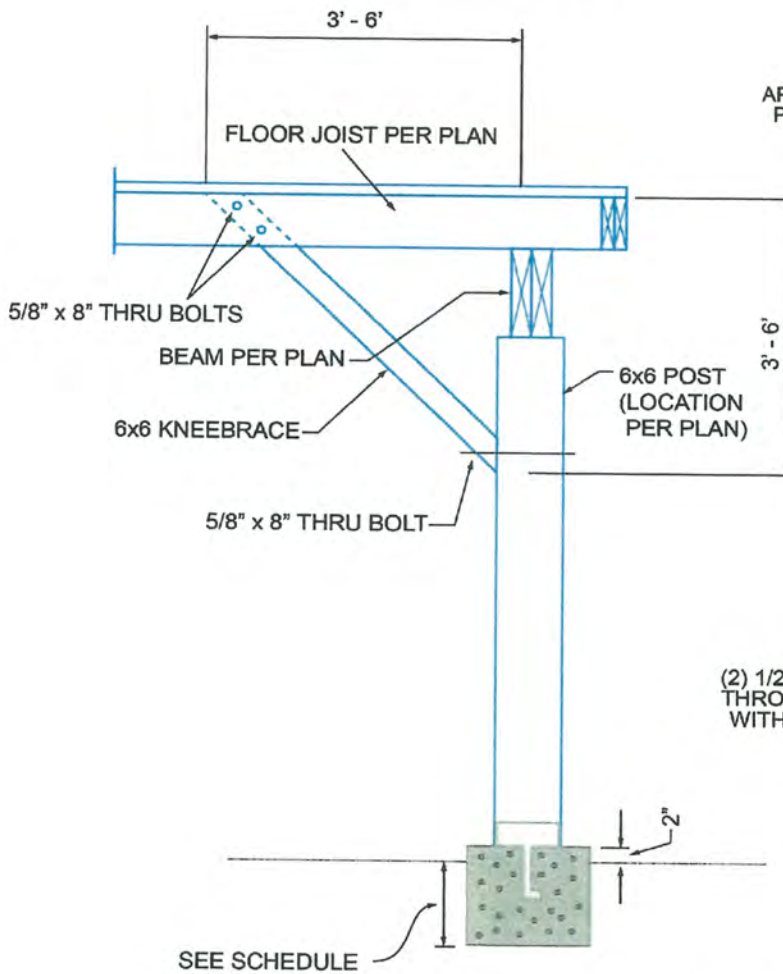

POST CAP

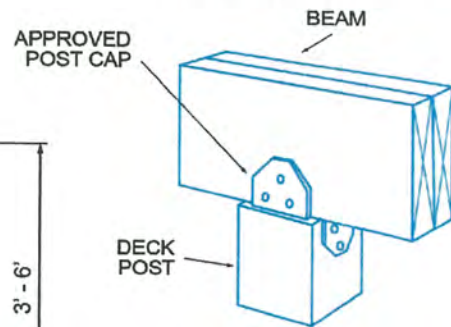

NOTCHED POST

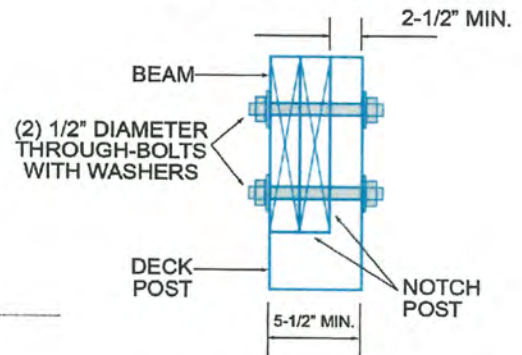

8'-0" MAX. GRADE TO TOP OF DECKING
NOT FOR CONSTRUCTION TO BE ENGINEERED TO LOCAL CODES

NOT TO SCALE

Tools Required & Tips for Success

Tools Required:

Carpenter's level	Hearing protection	Ruler
Carpenter's square	Hammer	Safety glasses
Chalk line	Hand saw	Screwdrivers
Chisel	Hoe and hose (to mix concrete)	Shims or spacers
Circular saw	Ladder	Shovel
Claw hammer	Line	Socket wrench
Combination square	Mallet	Stakes or batter boards
Crescent wrench	Nail set	String
Drills and bits	Pencils	Tamper
Dust mask	Pick	Tape measure
Extension cord	Plumb bob	Transit
Framing square	Post hole digger	Tool belt
Gloves	Rafter square	Two foot level

Tips for success:

1. When cutting or drilling wood, always wear eye protection to prevent injury from flying wood particles
2. When cutting lumber, a fabric breathing mask will help to avoid ingestion of the dust. Wear gloves as the surface is rough and can cause splinters.
3. For outdoor projects, nails and other hardware should be hot-dipped zinc-coated or equally well-protected material to keep them from rusting.
4. To help prevent splitting, drill pilot holes in each piece of lumber before nailing or screwing.
5. Make sure to treat your deck to prolong its lifespan.
6. Before you apply a finish on your deck, test for moisture by sprinkling the surface of a small area of the deck with water. If the droplets bead up, the wood is still wet. Wood that is dry enough for treatment will quickly soak up the water.
7. Deck finishes come in both water and oil based. While oil-based finishes penetrate deeper into the wood, water-based products are easier to clean up and are more forgiving in damp conditions.
8. When applying finish or cleaner to your deck, protect surrounding vegetation by wetting with a hose and covering with plastic.
9. Invest in a pair of kneepads if you are doing floor jobs or working on a deck.
10. Dispose of scraps in the regular trash or take to a landfill - never burn.



Below are the Specifications And Materials that you have selected for your deck.

Overview	Number of Levels: 1	Footer Depth: 24"
	Total Square Feet: 95	Live Load: 69 Dead Load: 10

Component	Size	Wood Type
Joists	2x8	Top Choice Treated
Beams	2x8	Top Choice Treated
Posts	6x6	Top Choice Treated
Decking	2x6	Pressure Treated
Railing		Pressure Treated
Lattice		treated

FooterDepth	24"	Live Load	69 psf
		Dead Load	10 psf

Material List
Lumber Materials

Item Number	Quantity	Description	Usage
93913	1	Top Choice Southern Yellow Pine Premium Wood Lattice (Common: 1-in x 4-ft x 8-ft; Actual: 0-in x 4-ft x 8-ft)	Lattice
468939	13	Top Choice #2 Prime Pressure Treated Lumber (Common: 2 x 8 x 10; Actual: 1.5-in x 7.25-in x 10-ft)	Beam
4644	4	Severe Weather 4-Step Alkaline Copper Quat Treated Deck Stair Stringer	Pre Cut Stringer
639134	1	Severe Weather #2 Pressure Treated Lumber (Common: 4 x 4 x 8-ft; Actual: 3.5-in x 3.5-in x 8-ft)	Railing Post
468954	2	#2 Pressure Treated Lumber (Common: 4 x 4 x 16; Actual: 3.5-in x 3.5-in x 16-ft)	Railing Post
468966	23	#1 Pressure Treated Lumber (Common: 2 x 2 x 8; Actual: 1.5-in x 1.5-in x 96-in)	Baluster
468930	1	Top Choice #2 Prime Pressure Treated Lumber (Common: 2 x 4 x 8; Actual: 1.5-in x 3.5-in x 96-in)	Railing Section
468933	1	Top Choice #2 Prime Pressure Treated Lumber (Common: 2 x 4 x 16; Actual: 1.5-in x 3.5-in x 16-ft)	Railing Section
468943	2	Top Choice #2 Prime Pressure Treated Lumber (Common: 2 x 10 x 10; Actual: 1.5-in x 9.25-in x 10-ft)	Cladding
468935	20	Top Choice #2 Prime Pressure Treated Lumber (Common: 2 x 6 x 10; Actual: 1.5-in x 5.5-in x 10-ft)	Decking
468960	1	#2 Pressure Treated Lumber (Common: 6 x 6 x 8; Actual: 5.5-in x 5.5-in x 96-in)	Post
468935	1	Top Choice #2 Prime Pressure Treated Lumber (Common: 2 x 6 x 10; Actual: 1.5-in x 5.5-in x 10-ft)	Stair Step
468937	1	Top Choice #2 Prime Pressure Treated Lumber (Common: 2 x 6 x 16; Actual: 1.5-in x 5.5-in x 16-ft)	Stair Step
468938	1	Top Choice #2 Prime Pressure Treated Lumber (Common: 2 x 8 x 8; Actual: 1.5-in x 7.25-in x 96-in)	Stringer Support

Other Materials

Item Number	Quantity	Description	Usage
116239	14	USP 2-in x 8-10-in Triple Zinc Slant Nail Joist Hanger	Joist Framing
69262	1	Grip-Rite 5 lb 9-Gauge 3-in Hot-Dipped Galvanized Smooth Nails	Joist Framing
69139	1	Grip-Rite 1 lb 9-Gauge 3-in Hot-Dipped Galvanized Smooth Nails	Joist Framing
37164	4	USP1-5/16-in x 2-3/8-in x 6-15/16-in Triple Zinc Angle Clip	Joist Framing
8082	2	USP 4-in x 4-in Triple Zinc Deck Post Tie	PostBmOrLedger
193212	5	The Hillman Group 1/2-in x 10-in HDG Anchor Bolt	PostBmOrLedger
21993	9	USP 1-1/2-in x 6-1/2-in Triple Zinc Rafter Tie	Joist Framing
56928	1	Grip-Rite 5 lbs 9-Gauge 1-1/2-in Hot Dipped Galvanized Smooth Joist Hanger Nails	Joist Framing
10385	7	QUIKRETE 80 lbs Setting Post Concrete Mix	Footing to Post
4030	1	QUIKRETE 40 lbs Concrete Mix	Footing to Post
10150	2	QUIKRETE 12-in Concrete Forming Tube	Footing to Post
69141	1	1 lb 8-Gauge 3-1/2-in Hot-Dipped Galvanized Smooth Nails	Footing to Post
6472	3	USP 6-in x 6-in Steel G185 Post Base	Footing to Post
140319	12	USP 6-in x 6-in Steel G185 Post Base	Post to Beam



Other Materials			
Item Number	Quantity	Description	Usage
29926	4	USP 1-3/4-in x 5-1/16-in Triple Zinc Slope/Skew Hanger	CladRimOrStair
67377	48	The Hillman Group 1/2-in- 13 x 8-in Hot-Dipped Galvanized Standard (SAE) Hex Bolt	Railing Post
58128	24	The Hillman Group 4-Count 1/2-in x 1-in Zinc Plated Standard (SAE) Flat Washer	Railing Post
43647	2	The Hillman Group 25-Count 1/2-in-13 Zinc Plated Standard (SAE) Hex Nuts	Railing Post
9470	1	5 lbs #8 x 3-in Countersinking-Head Galvanized Deck Screws	Deck Planking

Your Custom Deck Estimate

Estimated materials cost with your custom selections:

\$1,093 - \$1,149

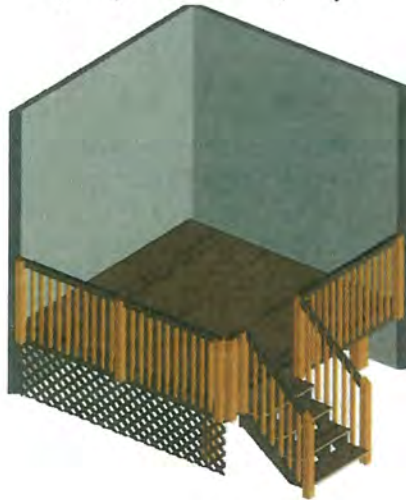

Your Custom Selections

Decking Type: Pressure Treated

Decking Size: 2x6

Decking Color: Pressure Treated

Railing Material: Pressure Treated

Railing Style: Standard Railing without Bottom Rail

Railing Color: Pressure Treated

Joist Spacing: 16"

Joist Wood Type: Top Choice Treated

Joist Size: 2x8

Beam Size: 2x8

Post Wood Type: Top Choice Treated

Post Size: 6x6

A detailed materials list, which includes the item numbers of products to purchase, can be found on page 10.

Estimated materials cost with basic selections: \$780 - \$820

Decking Type: Pressure Treated

Decking Size: 5/4x6

Railing Material: Pressure Treated

Railing Style: Pre-Assembled Railing

Joist Spacing: 16"

Joist Wood Type: Top Choice Treated

Joist Size: 2x8

Beam Size: 2x8

Post Wood Type: Top Choice Treated

Post Size: 4x4

Note: Estimates are based on representative costs of materials in your geographic area. Actual, current material costs and availability may vary by location, and are routinely subject to change. Contact your local Lowe's store for product availability, pricing, and other assistance.



Beam Layout Level 1

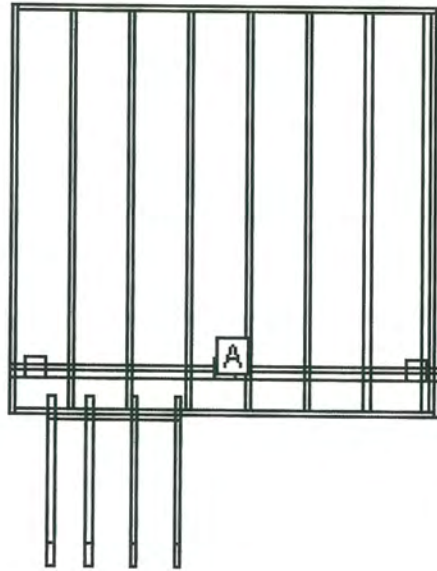

BEAM LABEL

A

BEAM LENGTH

9' 9"

POST COUNT

3

POST SPACING

4' 3 3/4"

Materials Cut List: Level 1

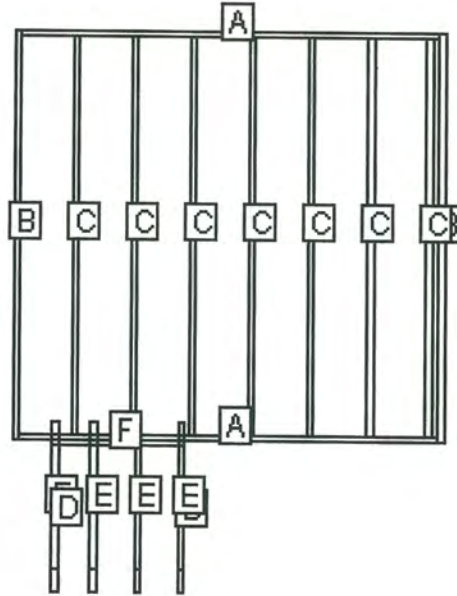

LABEL	NAME	QTY	LENGTH	BEVELS	LABEL	NAME	QTY	LENGTH	BEVELS
A	Header	2	9' 6"	0, 0	D	Cladding	2	4' 1 1/2"	0, 0
B	Rim Joist	2	9' 3"	0, 0	E	Pre Cut Stringer	4	4' 1 1/2"	0, 0
C	Internal Joist	7	9'	0, 0	F	Stringer Support	1	3'	0, 0

Cut Angles: L=Left, R=Right, F=Front, S=Side

Analysis Page: Level 1



LOAD AND SUPPORT:

Your deck will support a 69 PSF live load.
Posts have 24" below ground support.

DECK AND POST HEIGHT:

You selected a height of 36" from the top of the decking to the ground level. The top of the deck support posts will therefore be 26" above ground level.

Joists:

Set joists on top of beams, 16"; center to center.

Stress Analysis: Level 1

Joist Deflection	264
Joist Bending	79
Joist Shear	123
Joist Compression	123
Beam Deflection	1750
Beam Bending	194
Beam Shear	146
Post Stability	335

Warning: You have prepared a preliminary design of a deck for residential purposes, including the preparation of a preliminary bill of materials and a preliminary materials pricing estimate. Materials pricing estimates do not include labor costs and are subject to change. This preliminary design is NOT intended for use as a final design and may not be sufficient for permit applications. Variations in building codes, specific architectural considerations, and/or site conditions may require changes to the preliminary design. You are responsible for the final structural, code compliance, material usage, and structural safety of this design. Be sure to check and verify the design with your architect, engineer and building inspector.

Lowe's does not assume any responsibility for design, engineering, or construction; for the use of installation of materials; or for compliance with any building code or standard of workmanship. You should consult with professionals (including an architect, engineer, licensed contractor, and/or building inspector or code official) concerning the suitability, safety, and legality of this preliminary design, rather than relying on this tool for those functions. Always refer to information on fastener packaging for use with pressure treated lumber.

Preferences: Certain assumptions have been made in order to provide an accurate material quote for your deck project. Because local codes and bylaw requirements may vary throughout the country (e.g., by municipality and state/province), it is imperative that you check with your architect, engineer, licensed contractor, and/or building inspector or code official for compliance with local requirements and building codes. The following building practice assumptions have been made in planning the materials for your project:

Footer Depth:	24"
Footer Type:	Post On Concrete
Joist Cantilever:	6 inches
Joist Spacing:	16" center to center
Spacing Between Deck Planking:	1/8"
Stair Stringers:	10 inches
Deck Live Load:	40 psf
Deck Dead Load:	10 psf
Stairs Live Load:	40 psf
Stairs Dead Load:	10 psf

Be sure to check and verify the design with your architect, engineer and building inspector.

Note: It is recommended that joist that meet on top of beams should be spliced with gussets. The gussets should be 2- by wood the same width at the joist and overlap by 6 inches on each side. These gussets should be held in place with 12 16d galvanized nails.

Handling Precautions for Pressure-Treated Wood

Disposal: Dispose of treated wood by ordinary trash collection. Treated wood should not be burned in open fires, stoves, fireplaces, or residential boilers because toxic chemicals may be produced as part of the smoke and ashes. Treated wood from commercial or industrial use (e.g construction sites) must be disposed of in accordance with state and Federal regulations, which may include burning only in commercial or industrial incinerators or boilers. Always refer to information on fastener packaging for use with pressure treated lumber.

Operating Conditions: Avoid frequent or prolonged inhalation of sawdust from treated wood. When sawing, sanding and machining treated wood, wear a dust mask. Whenever possible, these operations should be performed outdoors to avoid indoor accumulations of airborne sawdust from treated wood. (Lowe's instore saws are equipped with a vacuum to minimize airborne sawdust).

Protection: When power-sawing and machining, wear goggles to protect eyes from flying particles.

Clean Thoroughly: Wear gloves when working with the wood. After working with the wood, and before eating, drinking, toileting, and use of tobacco products, wash exposed areas thoroughly.

Wash Separately: Because preservatives or sawdust may accumulate on clothes, they should be laundered before reuse. Wash work clothes separately from other household clothing.

For Additional Information: www.epa.gov - www.healthybuilding.net - www.ccasafetyinfo.com
www.treatedwood.com - Call: (800)282-0600 or (800)356-AWPI



NEVER STOP
IMPROVING.

DECK DESIGNER

powered by  DIY Technologies

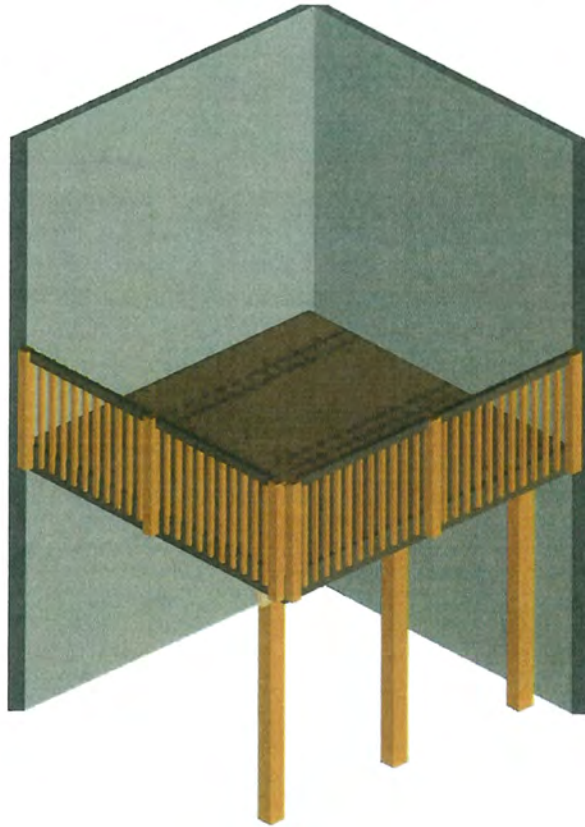

Lowe's Deck Design

2238 W. Grace Street Top Deck

Print this document and take it to the Doors and Windows desk or Commercial Sales desk
at your local Lowe's store.

One of our associates will help you find the materials you need.

Your Deck Design's Project ID is:
329990563

Created on May-29-2015

All rights reserved copyright ©2015 DIY Technologies

Project ID: 329990563

Store# 2863

Deck layout diagram



Top view without planks



Bottom view with planks

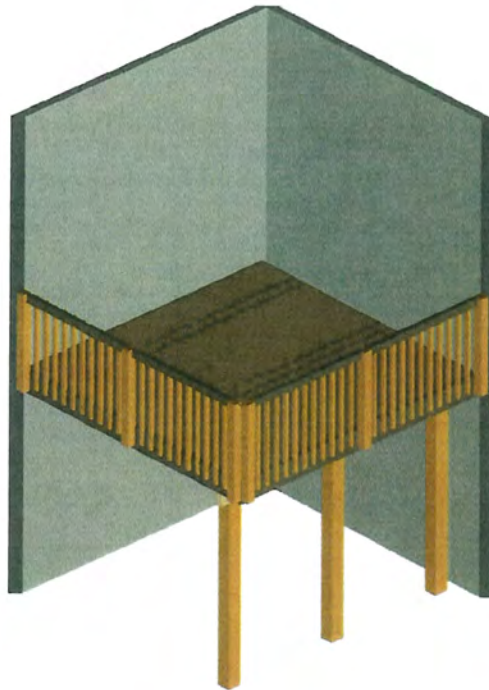

Top view with planks

Deck Part Identification

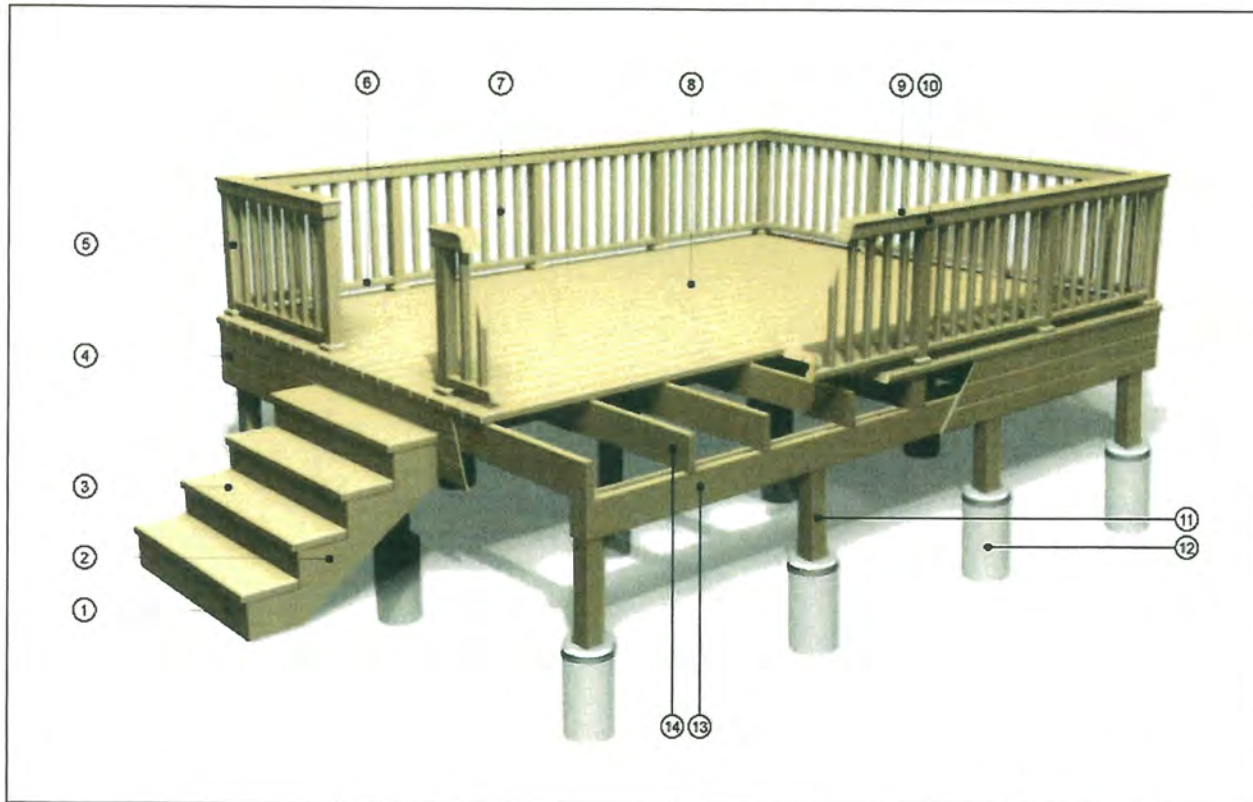

1. Riser	6. Bottom Rail	11. Post	Major Deck Components NOTE: Not to scale ©2015 DIY Technologies
2. Stringer	7. Baluster	12. Post Footer	
3. Tread	8. Decking	13. Beam	
4. Fascia	9. Rail Cap	14. Joist	
5. Rail Post	10. Top Rail		

Baluster	The vertical pieces of a railing spaced at regular intervals between posts.
Beam	A horizontal framing piece, which rests on posts and supports joists.
Decking	The boards used to make the walking surface of the deck.
Joist	A horizontal frame piece that supports the decking and spreads the weight over the beams.
Ledger	A horizontal strip that connects the deck to the house.
Post Footer	Concrete filled hole that the post is attached to.
Post	A vertical framing piece, used to support a beam or joist.
Riser	A board attached to the vertical cut surface of a stair stringer.
Stringer	The diagonal board used to support treads and risers on a stairway.
Tread	The horizontal surface of a stair.
Bottom Rail	The lower horizontal piece that connects rail posts and supports balusters.
Top Rail	The upper horizontal piece that connects rail posts and supports balusters.
Rail Cap	The top horizontal trim on railing.
Rail Post	The vertical post connected to the deck framing that supports the railing.

Structural Connector Hardware Guide

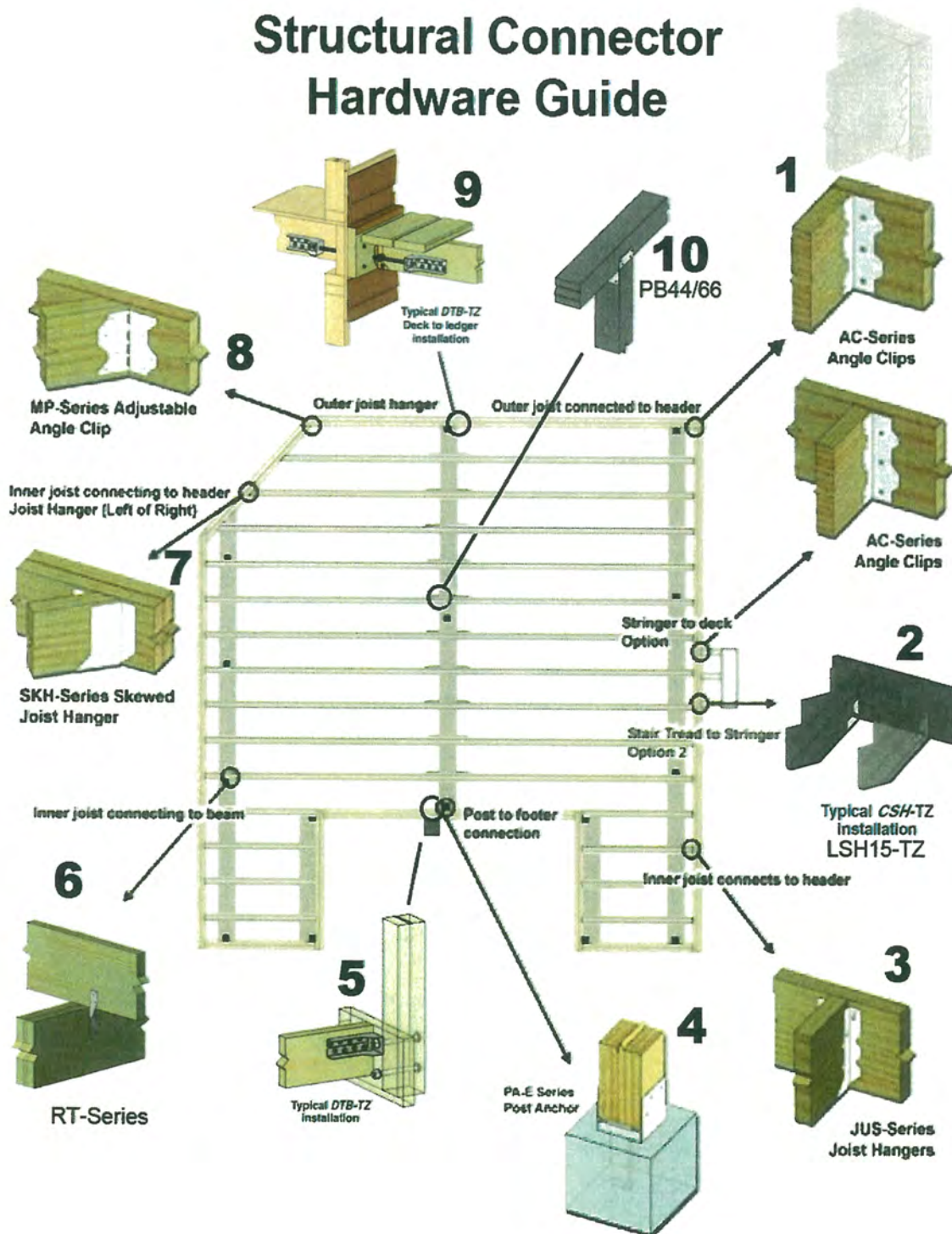

INSTALLATION CHECKLIST

General legal requirements

Check title restrictions and easements, building codes and zoning by-laws to make sure your deck design complies.

Obtain any required permits or zoning variances.

Check with local utility companies to make sure deck footings and construction will not disturb or obstruct access to piping or wiring.

Deck function

While planning your deck, determine how it will be used.

Your climate

While planning your deck, consider local weather.

Take advantage of good views.

Install ledger

Install ledger to anchor deck to house.

Ledger placement determines the deck floor level, normally 2-4" below floor line.

If unsure about attaching a ledger board, consult a professional.

Use batterboards and mason's string to mark off deck area and locate footing.

Square with string

Attach string to ledger and/or batterboards.

Batterboards go just outside perimeter corners of the deck.

Use the 3-4-5 method to get a 90 degree angle in one corner.

Footing requirements

Footing/posthole depth and location is dictated by local codes and by-laws.

INSTALLATION CHECKLIST

Attach beams to posts

Determine the desired deck floor height on the posts.

Determine height for securing the top of the beam to the post.

Attach joists

Joists are attached to ledger board with joist hangers or by toenailing.

Determine where blocking will go and snap a chalk line, but make sure to stagger pieces for ease of nailing.

Lay decking

Attach boards "bark side up" to minimize cupping and warping.

The deck boards can be trimmed after they are installed.

Railings

Railings must be firmly attached to the framing members of the deck.

Check local codes and by-laws for requirements on railings.

Stairs

Check local codes and by-law requirements on stairs.

Measure the rise and run of the stairs.

Multi-level decks

When planning a multi-level deck, for aesthetics make one deck larger than the other.

INSTALLATION CHECKLIST

Post bracing

Brace posts as dictated by local codes and by-laws.

BRACE AT JOIST

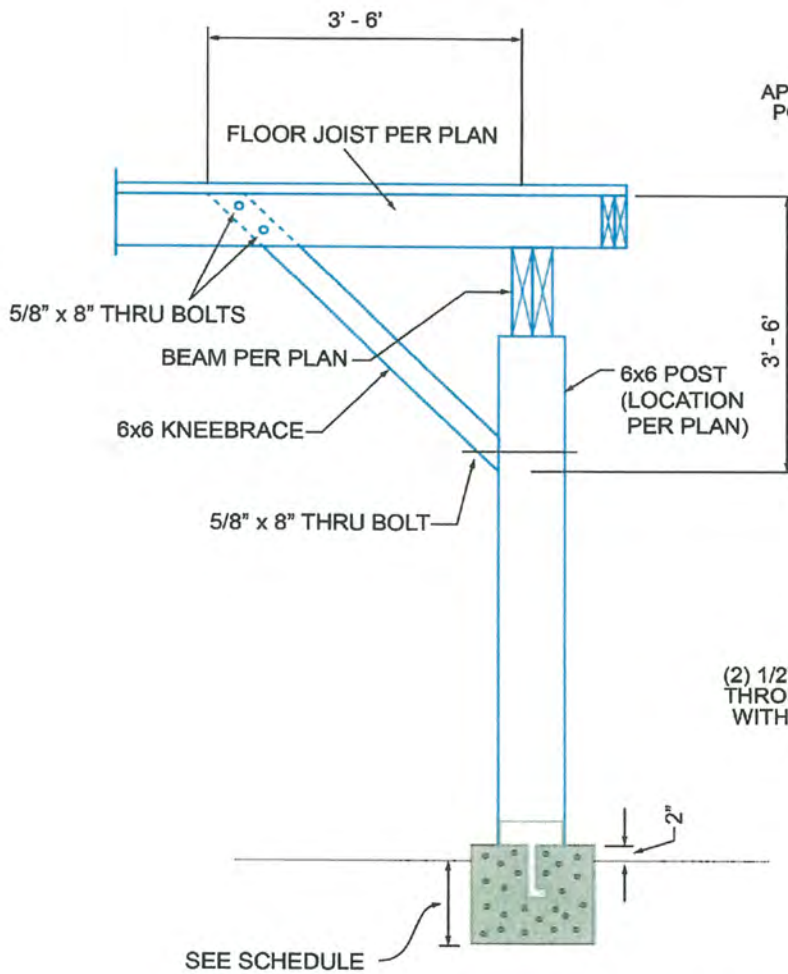

POST CAP

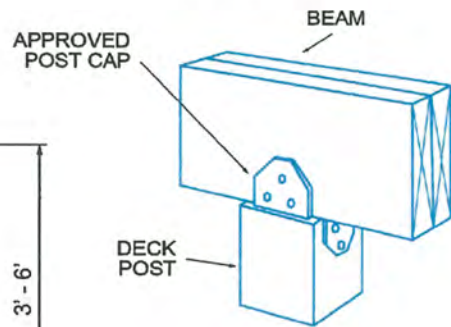

NOTCHED POST

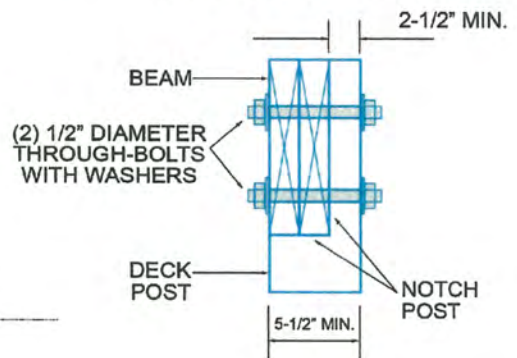

8'-0" MAX. GRADE TO TOP OF DECKING
NOT FOR CONSTRUCTION TO BE ENGINEERED TO LOCAL CODES

NOT TO SCALE

Tools Required & Tips for Success

Tools Required:

Carpenter's level	Hearing protection	Ruler
Carpenter's square	Hammer	Safety glasses
Chalk line	Hand saw	Screwdrivers
Chisel	Hoe and hose (to mix concrete)	Shims or spacers
Circular saw	Ladder	Shovel
Claw hammer	Line	Socket wrench
Combination square	Mallet	Stakes or batter boards
Crescent wrench	Nail set	String
Drills and bits	Pencils	Tamper
Dust mask	Pick	Tape measure
Extension cord	Plumb bob	Transit
Framing square	Post hole digger	Tool belt
Gloves	Rafter square	Two foot level

Tips for success:

1. When cutting or drilling wood, always wear eye protection to prevent injury from flying wood particles
2. When cutting lumber, a fabric breathing mask will help to avoid ingestion of the dust. Wear gloves as the surface is rough and can cause splinters.
3. For outdoor projects, nails and other hardware should be hot-dipped zinc-coated or equally well-protected material to keep them from rusting.
4. To help prevent splitting, drill pilot holes in each piece of lumber before nailing or screwing.
5. Make sure to treat your deck to prolong its lifespan.
6. Before you apply a finish on your deck, test for moisture by sprinkling the surface of a small area of the deck with water. If the droplets bead up, the wood is still wet. Wood that is dry enough for treatment will quickly soak up the water.
7. Deck finishes come in both water and oil based. While oil-based finishes penetrate deeper into the wood, water-based products are easier to clean up and are more forgiving in damp conditions.
8. When applying finish or cleaner to your deck, protect surrounding vegetation by wetting with a hose and covering with plastic.
9. Invest in a pair of kneepads if you are doing floor jobs or working on a deck.
10. Dispose of scraps in the regular trash or take to a landfill - never burn.

**Below are the Specifications And Materials
that you have selected for your deck.**

Overview	Number of Levels: 1 Total Square Feet: 95	Footer Depth: 24" Live Load: 69 Dead Load: 10
-----------------	--	---

Component	Size	Wood Type
Joists	2x8	Top Choice Treated
Beams	2x8	Top Choice Treated
Posts	6x6	Top Choice Treated
Decking	2x6	Pressure Treated
Railing		Pressure Treated
Lattice		

FooterDepth	24"	Live Load	69 psf
		Dead Load	10 psf

Material List

Lumber Materials			
Item Number	Quantity	Description	Usage
468939	13	Top Choice #2 Prime Pressure Treated Lumber (Common: 2 x 8 x 10; Actual: 1.5-in x 7.25-in x 10-ft)	Beam
639134	1	Severe Weather #2 Pressure Treated Lumber (Common: 4 x 4 x 8-ft; Actual: 3.5-in x 3.5-in x 8-ft)	Railing Post
468954	1	#2 Pressure Treated Lumber (Common: 4 x 4 x 16; Actual: 3.5-in x 3.5-in x 16-ft)	Railing Post
468966	21	#1 Pressure Treated Lumber (Common: 2 x 2 x 8; Actual: 1.5-in x 1.5-in x 96-in)	Baluster
468930	1	Top Choice #2 Prime Pressure Treated Lumber (Common: 2 x 4 x 8; Actual: 1.5-in x 3.5-in x 96-in)	Railing Section
468933	1	Top Choice #2 Prime Pressure Treated Lumber (Common: 2 x 4 x 16; Actual: 1.5-in x 3.5-in x 16-ft)	Railing Section
468943	2	Top Choice #2 Prime Pressure Treated Lumber (Common: 2 x 10 x 10; Actual: 1.5-in x 9.25-in x 10-ft)	Cladding
468935	20	Top Choice #2 Prime Pressure Treated Lumber (Common: 2 x 6 x 10; Actual: 1.5-in x 5.5-in x 10-ft)	Decking
468960	3	#2 Pressure Treated Lumber (Common: 6 x 6 x 8; Actual: 5.5-in x 5.5-in x 96-in)	Post

Other Materials			
Item Number	Quantity	Description	Usage
116239	14	USP 2-in x 8-10-in Triple Zinc Slant Nail Joist Hanger	Joist Framing
69262	1	Grip-Rite 5 lb 9-Gauge 3-in Hot-Dipped Galvanized Smooth Nails	Joist Framing
69139	1	Grip-Rite 1 lb 9-Gauge 3-in Hot-Dipped Galvanized Smooth Nails	Joist Framing
37164	4	USP1-5/16-in x 2-3/8-in x 6-15/16-in Triple Zinc Angle Clip	Joist Framing
8082	2	USP 4-in x 4-in Triple Zinc Deck Post Tie	PostBmOrLedger
193212	5	The Hillman Group 1/2-in x 10-in HDG Anchor Bolt	PostBmOrLedger
21993	9	USP 1-1/2-in x 6-1/2-in Triple Zinc Rafter Tie	Joist Framing
56928	1	Grip-Rite 5 lbs 9-Gauge 1-1/2-in Hot Dipped Galvanized Smooth Joist Hanger Nails	Joist Framing
10385	7	QUIKRETE 80 lbs Setting Post Concrete Mix	Footing to Post
4030	1	QUIKRETE 40 lbs Concrete Mix	Footing to Post
10150	2	QUIKRETE 12-in Concrete Forming Tube	Footing to Post
69141	1	1 lb 8-Gauge 3-1/2-in Hot-Dipped Galvanized Smooth Nails	Footing to Post
6472	3	USP 6-in x 6-in Steel G185 Post Base	Footing to Post
140319	12	USP 6-in x 6-in Steel G185 Post Base	Post to Beam
67377	42	The Hillman Group 1/2-in- 13 x 8-in Hot-Dipped Galvanized Standard (SAE) Hex Bolt	Railing Post
58128	21	The Hillman Group 4-Count 1/2-in x 1-in Zinc Plated Standard (SAE) Flat Washer	Railing Post
43647	2	The Hillman Group 25-Count 1/2-in-13 Zinc Plated Standard (SAE) Hex Nuts	Railing Post
9470	1	5 lbs #8 x 3-in Countersinking-Head Galvanized Deck Screws	Deck Planking

Your Custom Deck Estimate

Estimated materials cost with your custom selections:

\$976 - \$1,026

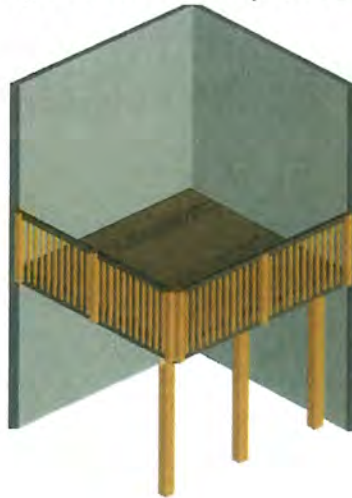

Your Custom Selections

Decking Type: Pressure Treated

Decking Size: 2x6

Decking Color: Pressure Treated

Railing Material: Pressure Treated

Railing Style: Standard Railing without Bottom Rail

Railing Color: Pressure Treated

Joist Spacing: 16"

Joist Wood Type: Top Choice Treated

Joist Size: 2x8

Beam Size: 2x8

Post Wood Type: Top Choice Treated

Post Size: 6x6

A detailed materials list, which includes the item numbers of products to purchase, can be found on page 10.

Estimated materials cost with basic selections: \$633 - \$665

Decking Type: Pressure Treated
Decking Size: 5/4x6
Railing Material: Pressure Treated
Railing Style: Pre-Assembled Railing
Joist Spacing: 16"

Joist Wood Type: Top Choice Treated
Joist Size: 2x8
Beam Size: 2x8
Post Wood Type: Top Choice Treated
Post Size: 4x4

Note: Estimates are based on representative costs of materials in your geographic area. Actual, current material costs and availability may vary by location, and are routinely subject to change. Contact your local Lowe's store for product availability, pricing, and other assistance.

Beam Layout Level 1

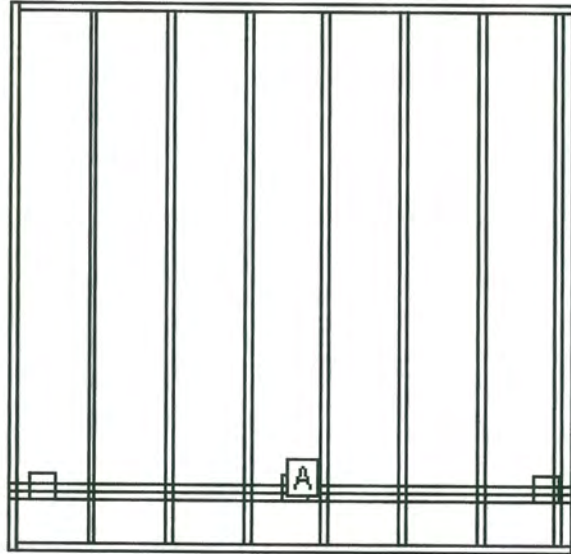

BEAM LABEL

A

BEAM LENGTH

9' 9"

POST COUNT

3

POST SPACING

4' 3 3/4"

Materials Cut List: Level 1

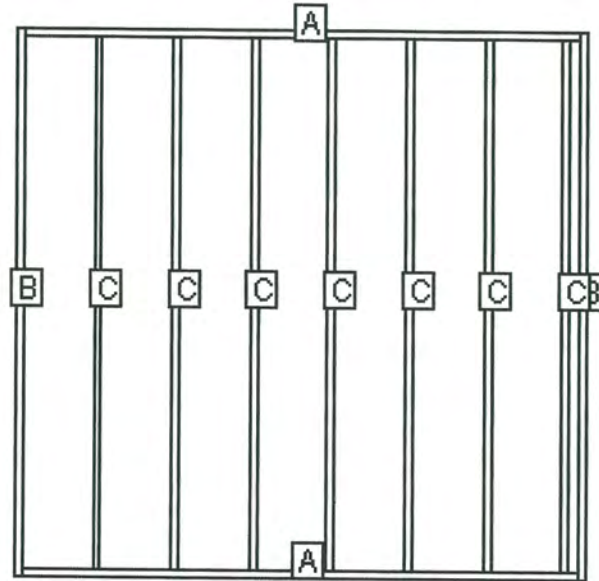

LABEL	NAME	QTY	LENGTH	BEVELS	LABEL	NAME	QTY	LENGTH	BEVELS
A	Header	2	9' 6"	0, 0	C	Internal Joist	7	9'	0, 0
B	Rim Joist	2	9' 3"	0, 0					

Cut Angles: L=Left, R=Right, F=Front, S=Side

Analysis Page: Level 1

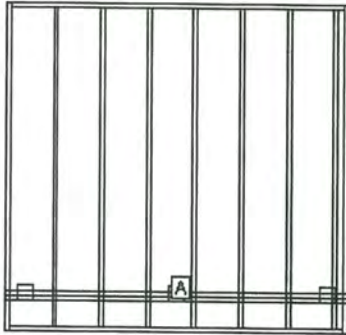

LOAD AND SUPPORT:

Your deck will support a 69 PSF live load.
Posts have 24" below ground support.

DECK AND POST HEIGHT:

You selected a height of 96" from the top of the decking to the ground level. The top of the deck support posts will therefore be 86" above ground level.

Joists:

Set joists on top of beams, 16"; center to center.

Stress Analysis: Level 1

Joist Deflection	264
Joist Bending	79
Joist Shear	123
Joist Compression	123
Beam Deflection	1750
Beam Bending	194
Beam Shear	146
Post Stability	335

Warning: You have prepared a preliminary design of a deck for residential purposes, including the preparation of a preliminary bill of materials and a preliminary materials pricing estimate. Materials pricing estimates do not include labor costs and are subject to change. This preliminary design is NOT intended for use as a final design and may not be sufficient for permit applications. Variations in building codes, specific architectural considerations, and/or site conditions may require changes to the preliminary design. You are responsible for the final structural, code compliance, material usage, and structural safety of this design. Be sure to check and verify the design with your architect, engineer and building inspector.

Lowe's does not assume any responsibility for design, engineering, or construction; for the use of installation of materials; or for compliance with any building code or standard of workmanship. You should consult with professionals (including an architect, engineer, licensed contractor, and/or building inspector or code official) concerning the suitability, safety, and legality of this preliminary design, rather than relying on this tool for those functions. Always refer to information on fastener packaging for use with pressure treated lumber.

Preferences: Certain assumptions have been made in order to provide an accurate material quote for your deck project. Because local codes and bylaw requirements may vary throughout the country (e.g., by municipality and state/province), it is imperative that you check with your architect, engineer, licensed contractor, and/or building inspector or code official for compliance with local requirements and building codes. The following building practice assumptions have been made in planning the materials for your project:

Footer Depth:	24"
Footer Type:	Post On Concrete
Joist Cantilever:	6 inches
Joist Spacing:	16" center to center
Spacing Between Deck Planking:	1/8"
Stair Stringers:	10 inches
Deck Live Load:	40 psf
Deck Dead Load:	10 psf
Stairs Live Load:	40 psf
Stairs Dead Load:	10 psf

Be sure to check and verify the design with your architect, engineer and building inspector.

Note: It is recommended that joist that meet on top of beams should be spliced with gussets. The gussets should be 2- by wood the same width at the joist and overlap by 6 inches on each side. These gussets should be held in place with 12 16d galvanized nails.

Handling Precautions for Pressure-Treated Wood

Disposal: Dispose of treated wood by ordinary trash collection. Treated wood should not be burned in open fires, stoves, fireplaces, or residential boilers because toxic chemicals may be produced as part of the smoke and ashes. Treated wood from commercial or industrial use (e.g construction sites) must be disposed of in accordance with state and Federal regulations, which may include burning only in commercial or industrial incinerators or boilers. Always refer to information on fastener packaging for use with pressure treated lumber.

Operating Conditions: Avoid frequent or prolonged inhalation of sawdust from treated wood. When sawing, sanding and machining treated wood, wear a dust mask. Whenever possible, these operations should be performed outdoors to avoid indoor accumulations of airborne sawdust from treated wood. (Lowe's instore saws are equipped with a vacuum to minimize airborne sawdust).

Protection: When power-sawing and machining, wear goggles to protect eyes from flying particles.

Clean Thoroughly: Wear gloves when working with the wood. After working with the wood, and before eating, drinking, toileting, and use of tobacco products, wash exposed areas thoroughly.

Wash Separately: Because preservatives or sawdust may accumulate on clothes, they should be laundered before reuse. Wash work clothes separately from other household clothing.

For Additional Information: www.epa.gov - www.healthybuilding.net - www.ccasafetyinfo.com
www.treatedwood.com - Call: (800)282-0600 or (800)356-AWPI