



COMMISSION OF ARCHITECTURAL REVIEW

APPLICATION / CERTIFICATE OF APPROPRIATENESS

PROPERTY (Location of Work)

Address 2101 E. BROAD ST. - RICHMOND, VA

Historic District St John's Church

PROPOSED ACTION

- | | | |
|---|--|---------------------------------------|
| <input checked="" type="checkbox"/> Alteration (including paint colors) | <input type="checkbox"/> Rehabilitation | <input type="checkbox"/> Demolition |
| <input type="checkbox"/> Addition | <input type="checkbox"/> New Construction (Conceptual Review required) | |
| | <input type="checkbox"/> Conceptual Review | <input type="checkbox"/> Final Review |

OWNER

Name KHANH LE
 Company _____
 Mailing Address 5710 CUTSHAW AVE
RICHMOND - VA 23226
 Phone (804)747-5596
 Email LETORONTO@AOL.COM
 Signature [Signature]
 Date 03/01/2017

APPLICANT (if other than owner)

Name _____
 Company _____
 Mailing Address _____
 Phone _____
 Email _____
 Signature _____
 Date _____

ACKNOWLEDGEMENT OF RESPONSIBILITY

Requirements: A complete application includes all applicable information requested on checklists to provide a complete and accurate description of existing and proposed conditions. Preliminary review meeting or site visit with staff may be necessary to process the application. Owner contact information and signature is required. Late or incomplete applications will not be considered.

Zoning Requirements: Prior to CAR review, it is the responsibility of the applicant to determine if zoning approval is required and application materials should be prepared in compliance with zoning.

Compliance: If granted, you agree to comply with all conditions of the COA. Revisions to approved work require staff review and may require a new application and CAR approval. Failure to comply with the COA may result in project delays or legal action. The COA is valid for one (1) year and may be extended for an additional year, upon written request.

(Space below for staff use only)

Application received RECEIVED 9:00 am
 Date/Time MAR 02 2017
 By _____

Complete Yes No

Khanh Le
5710 Cutshaw Ave
Richmond, VA 23226
Telephone: 804-747-5596 (home)/804-971-0160 (cell)

March 01, 2017

Commission of Architectural Review
Rm. 510, 900 E. Broad Street
Richmond, VA

To whom it may concern

Dear Sir/Madame:

I would like to request for approval the following alterations to my property located at 2101 E. Broad St. Richmond, VA 23223.

Stair railing in front of the house:

The current arrangement of the pickets will be changed as shown in the attached drawing. In addition, the stair railing will be painted in white.

Roof

The existing roofing of the house will be removed and replaced by the Thermoplastic Polyolefin (TPO) roofing.

Thank you very much for your time in considering this request. I am looking forward to hearing back from you on this matter.

Sincerely,



Khanh Le

(PROPOSED)

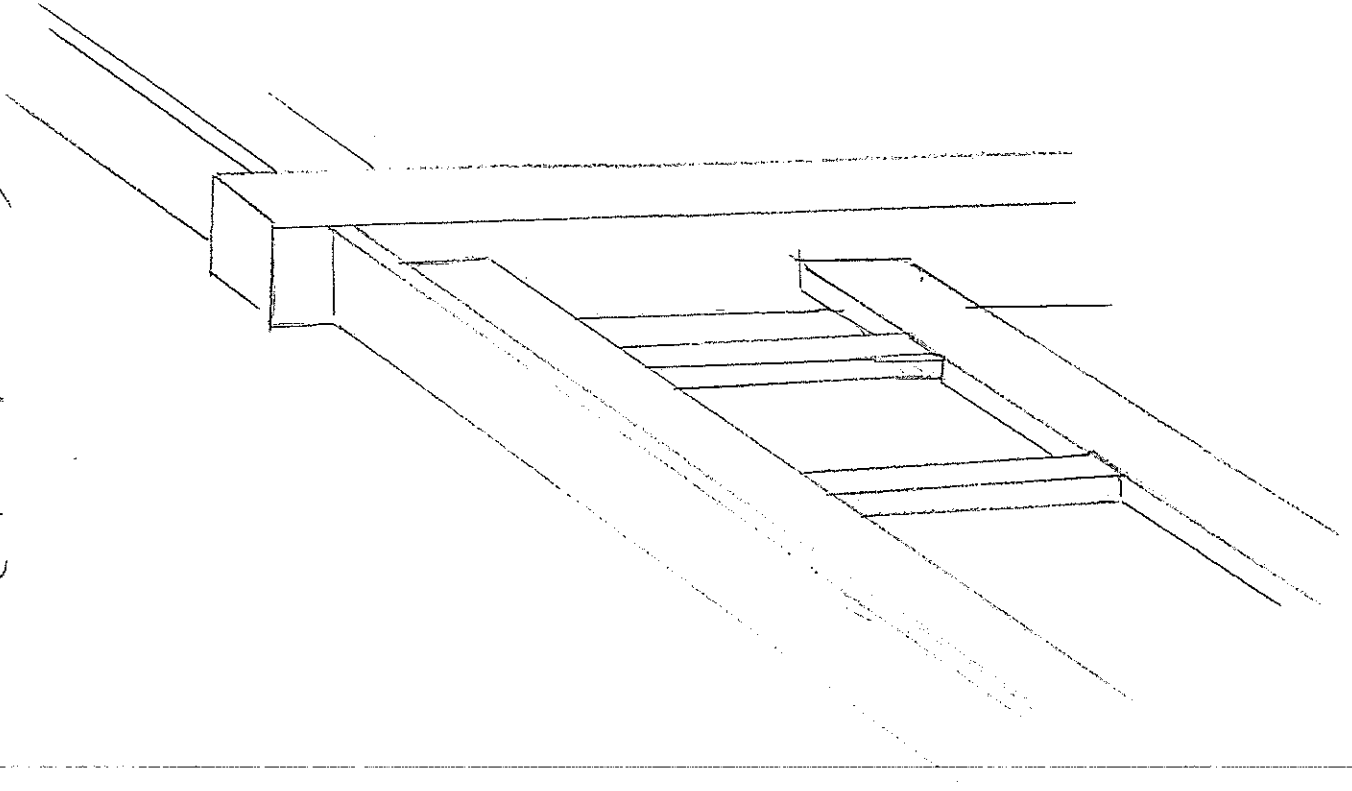

(CURRENT)

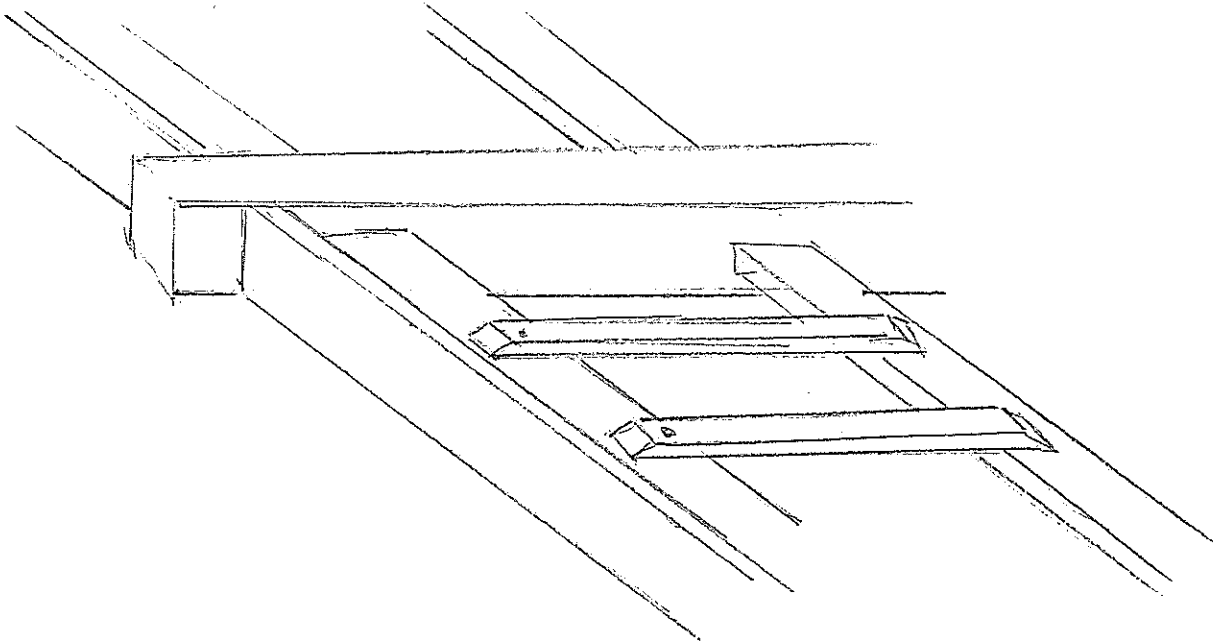



Google Maps 2101 E Broad St

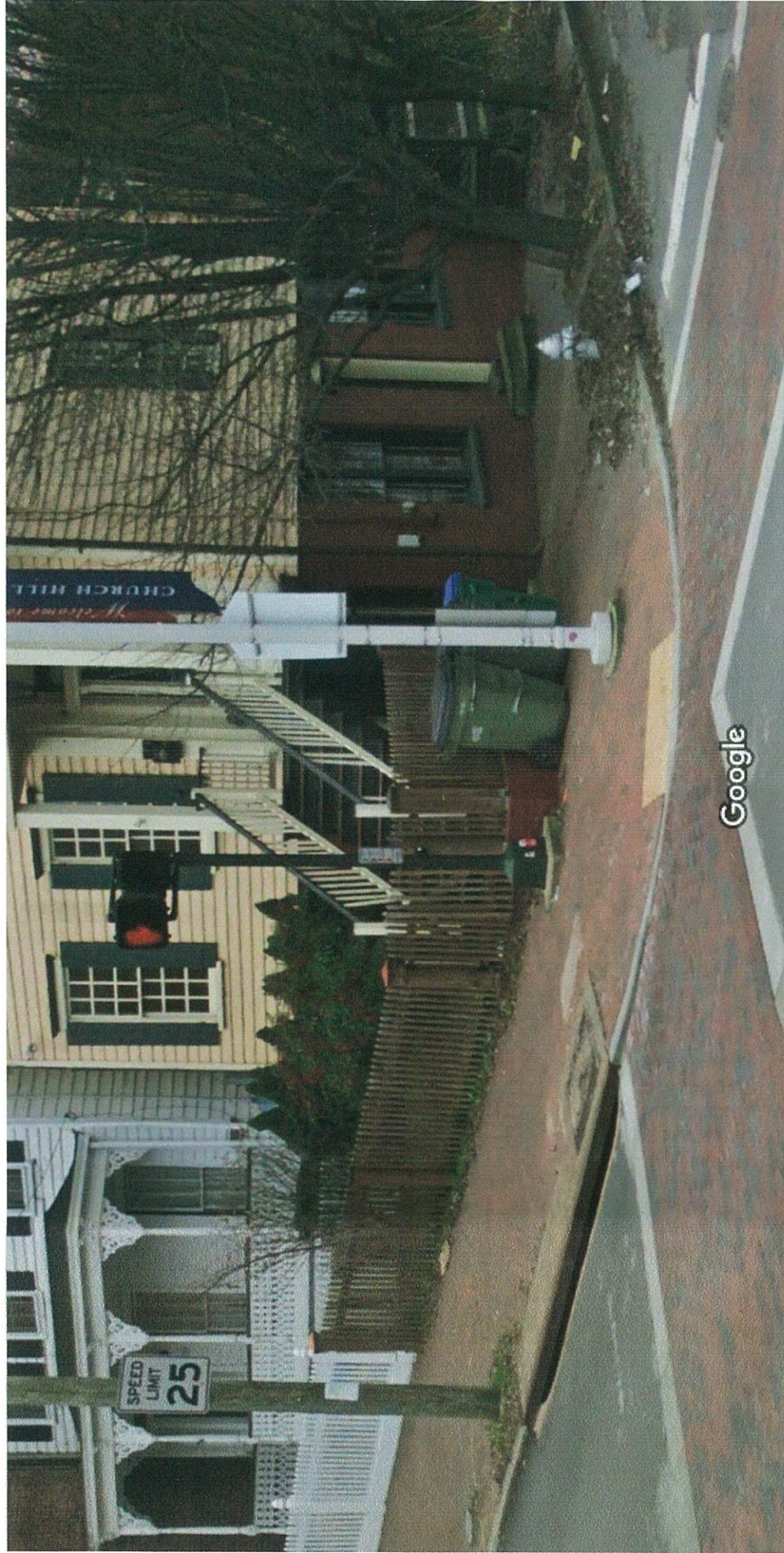

Image capture: Feb 2016 © 2017 Google

Richmond, Virginia

Street View - Feb 2016