

**Exhibit L to the Development Agreement**

**Master Plan**

# Master Plan



block	uses	min area by use gross floor square feet	area by block gross square feet	capital investment minimum
<b>A1</b>	arena	415,000	415,000	\$235,000,000
<b>A2</b>	multi-family residential	230,000	255,000	\$66,411,704
	retail	25,000		
<b>A3</b>	office	254,500	277,900	\$133,294,544
	retail	23,400		
<b>B</b>	multi-family residential	203,000	228,000	\$46,175,871
	retail	25,000		
<b>C</b>	multi-family residential	195,500	483,500	\$157,286,000
	office	213,000		
	GRTC Transit Center	65,000		
	retail	10,000		
<b>D</b>	office / research	475,000	645,000	\$307,272,848
	retail	15,000		
	hospitality	155,000		
<b>E</b>	multi-family residential	93,390	107,390	\$23,548,426
	retail	14,000		
<b>F1</b>	hotel	341,651	349,138	\$162,984,184
	retail	7,487		
<b>F2</b>	retail / food market	18,000	54,000	\$10,000,000
	hotel support	36,000		
<b>I</b>	multi-family residential or office	439,000	541,000	\$136,930,656
	retail	102,000		
<b>N</b>	multi-family residential or office	416,340	430,590	\$133,590,870
	retail	14,250		
<b>U</b>	multi-family residential and/or hotel	377,000	410,250	\$123,121,056
	retail	33,250		

# block A2

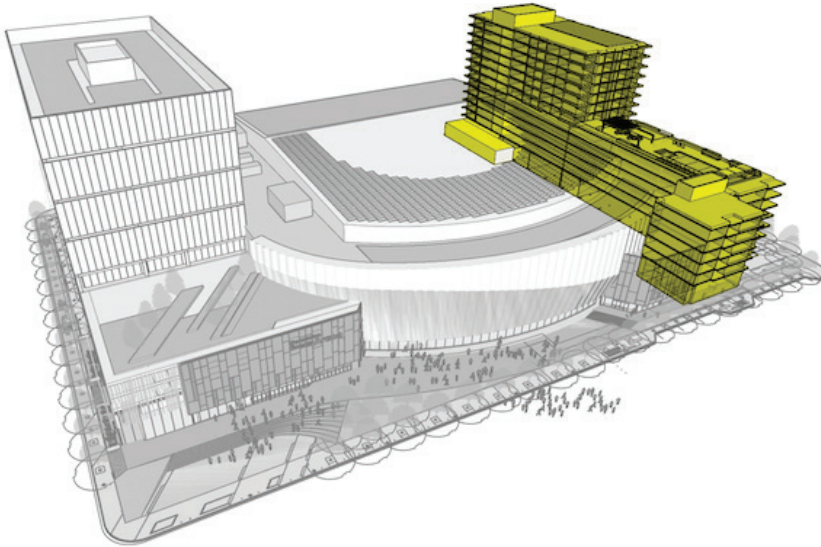

“A2” uses - Multi-family residential with ground-level retail.

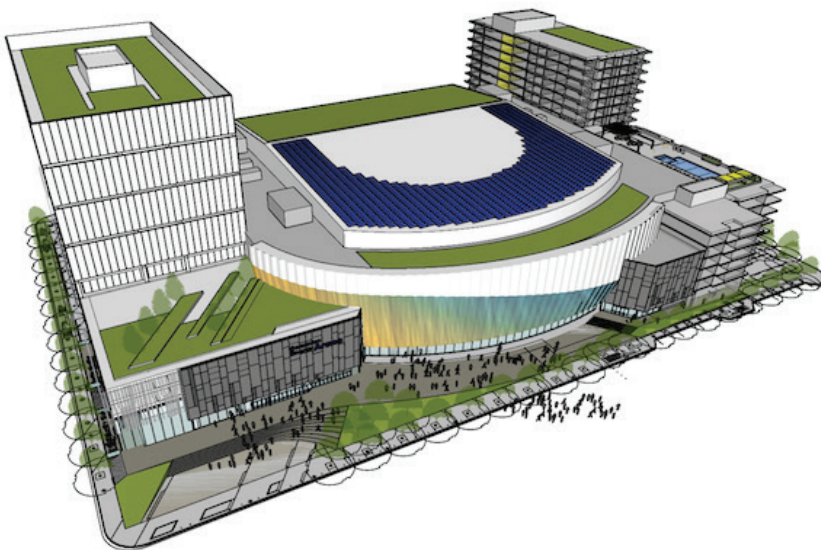

Arena with office, retail, residential uses adjacent

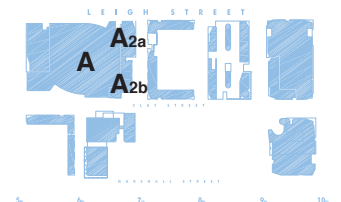

# block A3

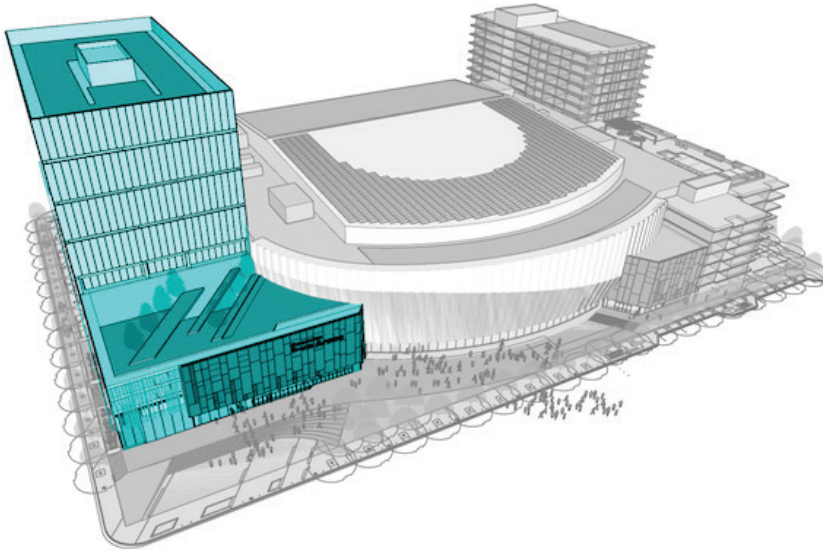

“A3” uses - Class A office

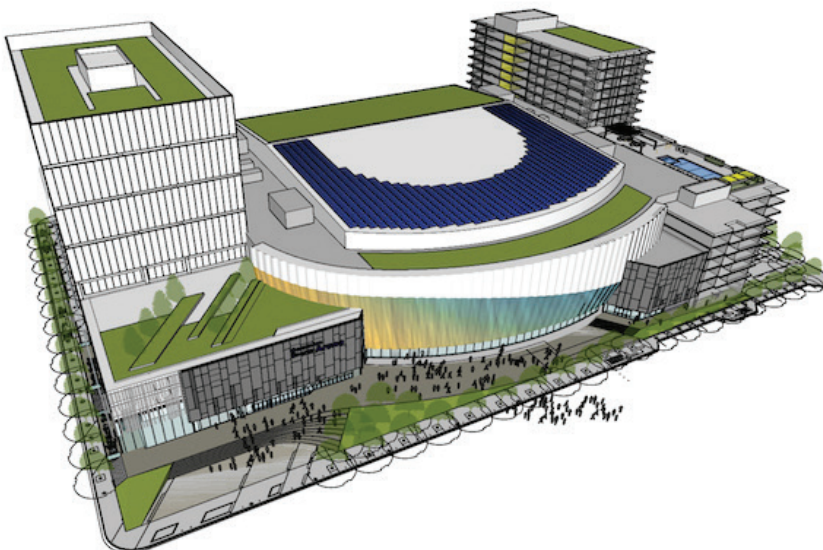

Arena with office, retail, residential uses adjacent

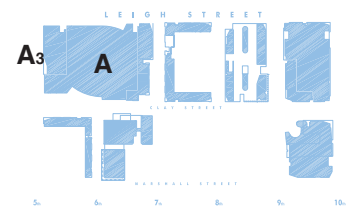

# block B

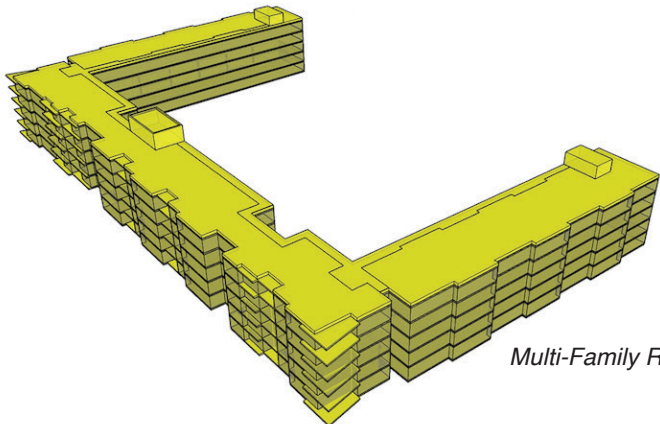

Multi-Family Residential

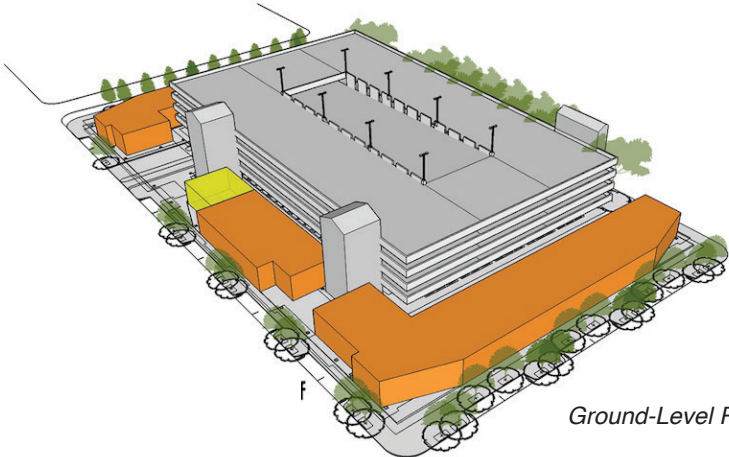

Ground-Level Retail

**“B” uses** - Multi-family residential with ground-level retail around existing parking structure

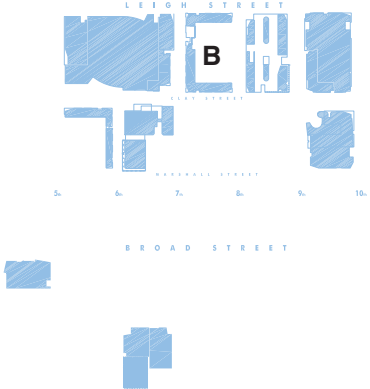
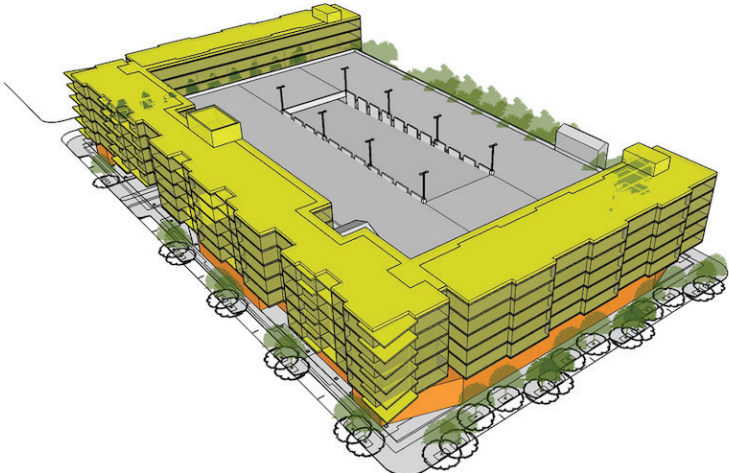

# block C

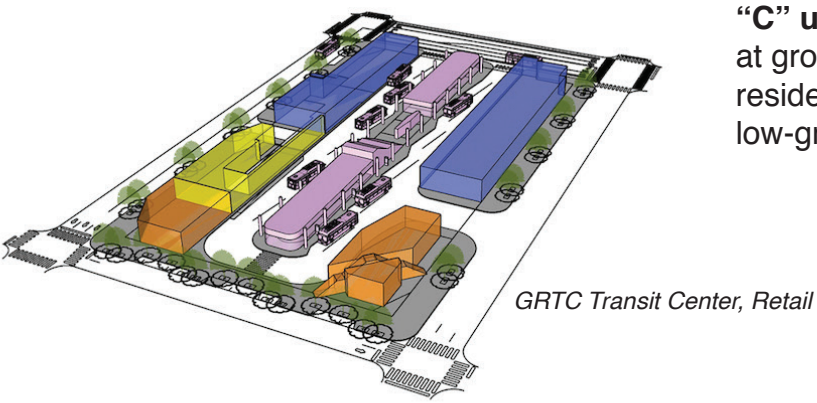
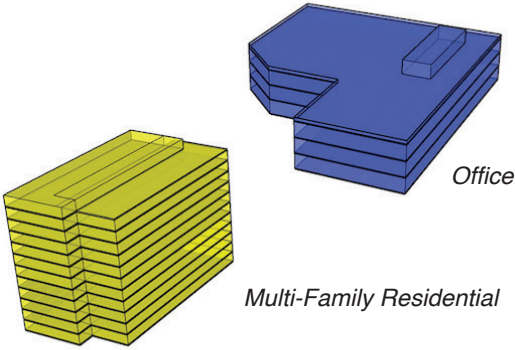

“C” uses - GRTC Transit Center at ground level, retail, multi-family residential, office, deck park, below-grade parking

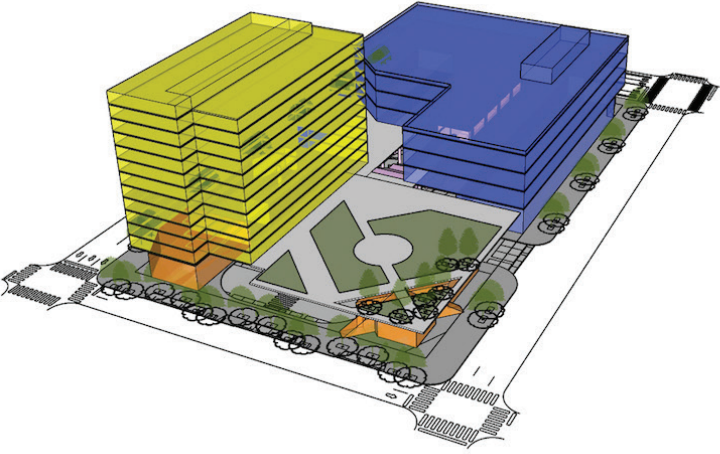
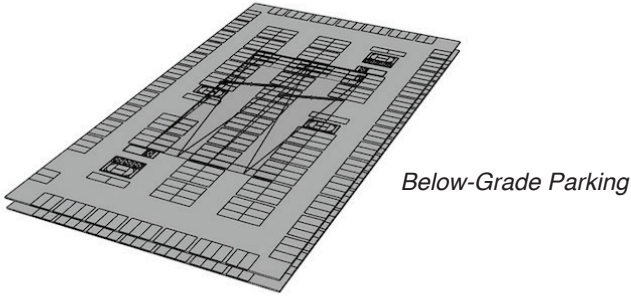

# block D

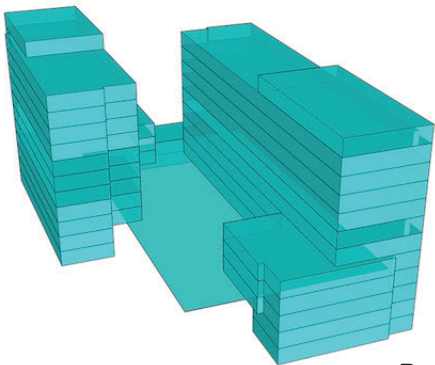

Research, Office

“D” uses - Research, office, parking, hospitality, ground-level retail

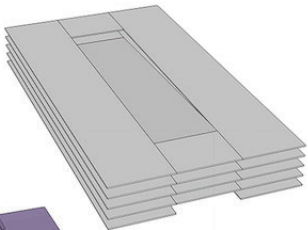

Parking

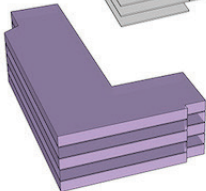

Hospitality

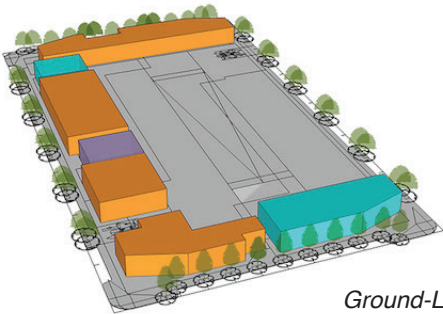

Ground-Level Commercial

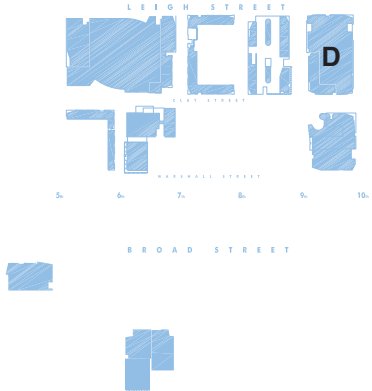
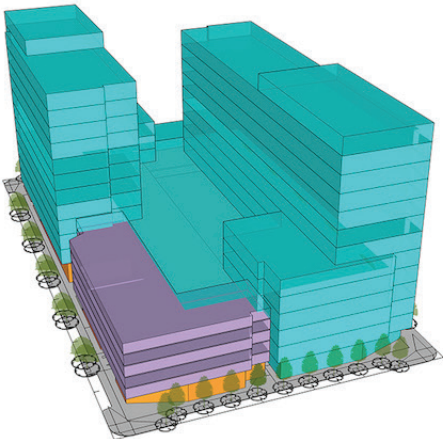

# block E

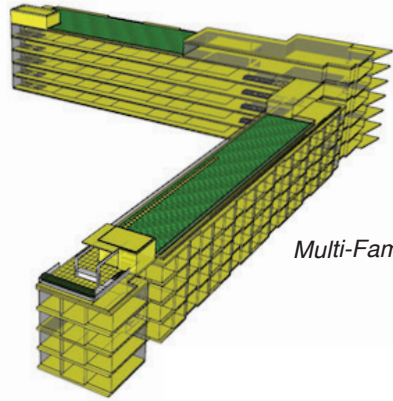

Multi-Family Residential

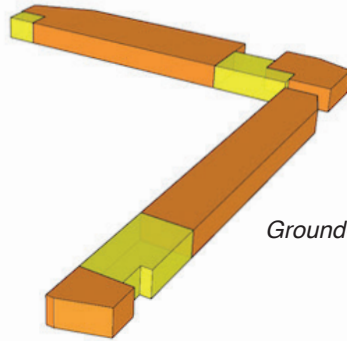

Ground-Level Retail

**“E” uses** - Multi-family residential with ground-level retail around existing parking structure

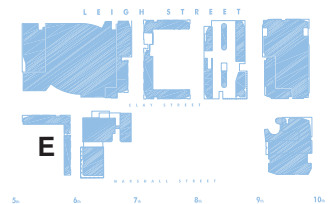
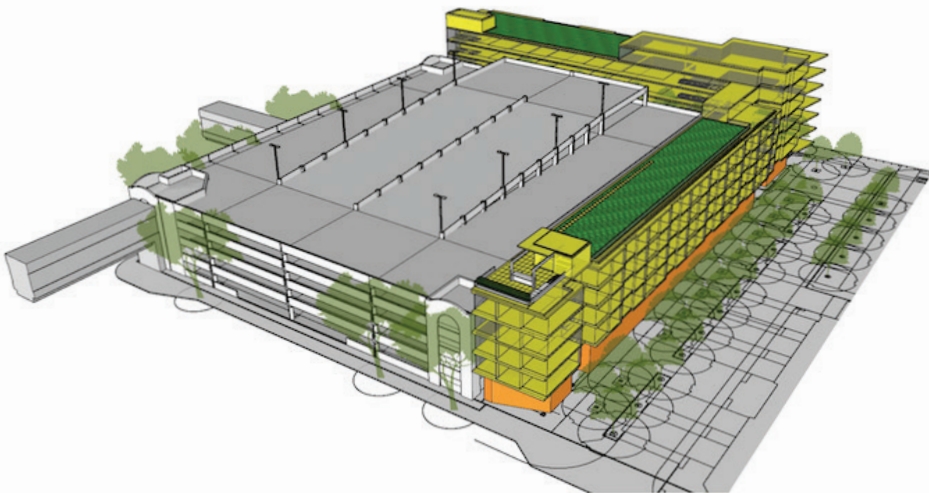



# block F1

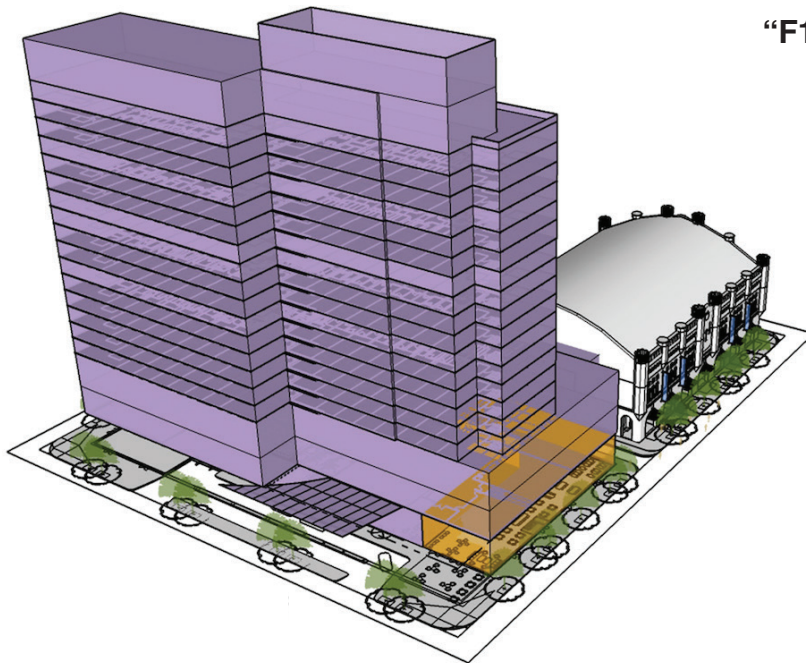

**“F1” uses** - Hotel and Conferencing,  
Retail

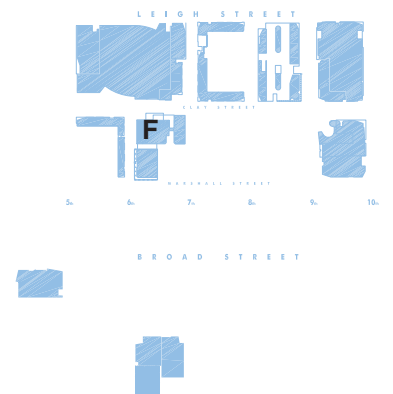

# block F2

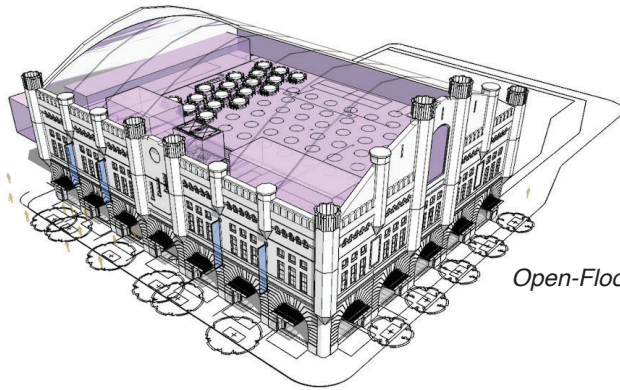

Open-Floor Ballroom

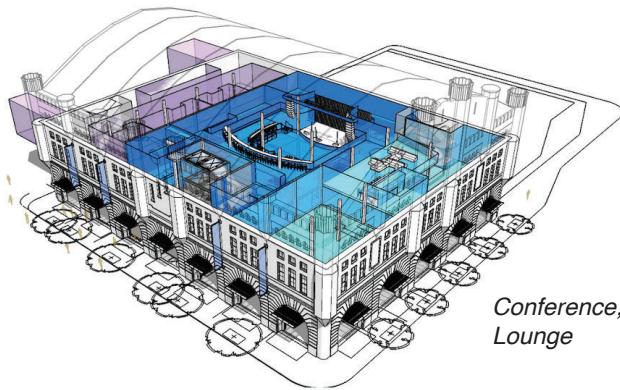

Conference, Theater,  
Lounge

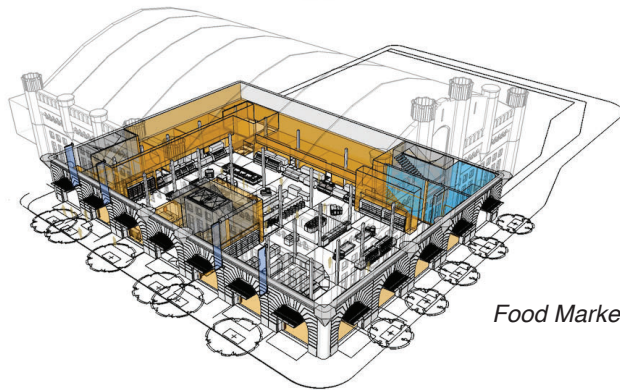

Food Market / Retail

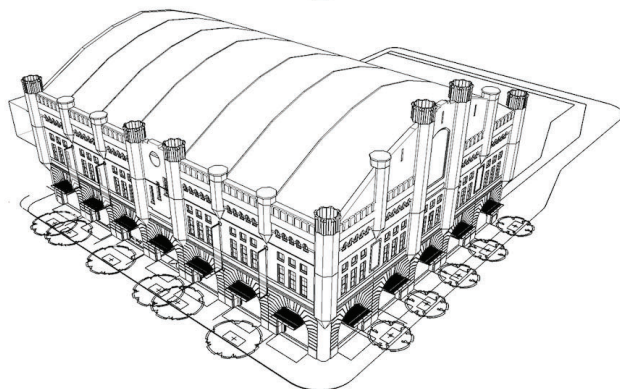

**“F2” uses** - Rehabilitation of Blues Armory, market, retail on ground level, theater, conferencing and lounge on level 2, Hotel Ballroom on level 3



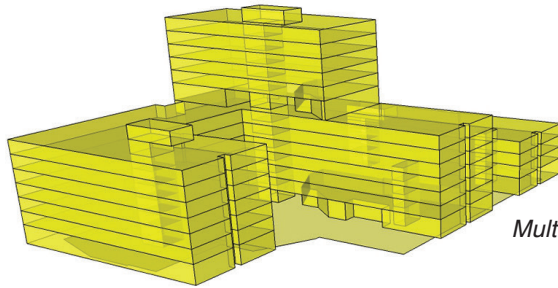

Multi-Family Residential

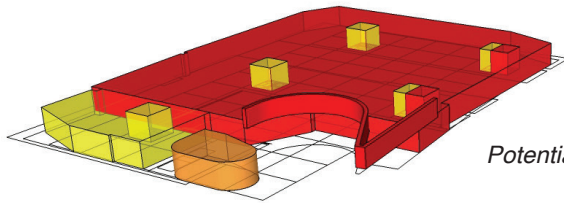

Potential 2nd-Level Retail

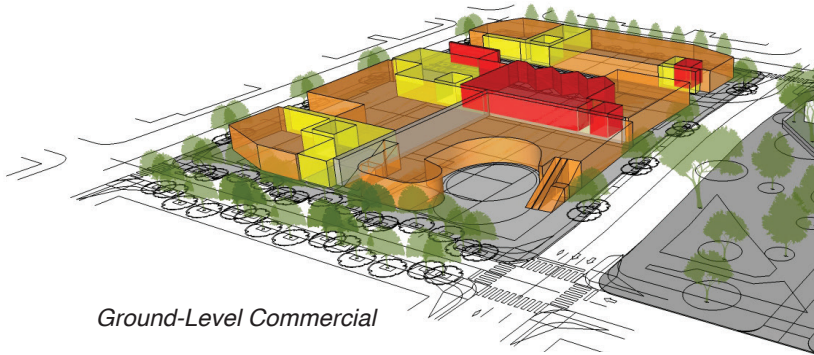

Ground-Level Commercial

“I” uses - multi-family residential, parking, retail or office

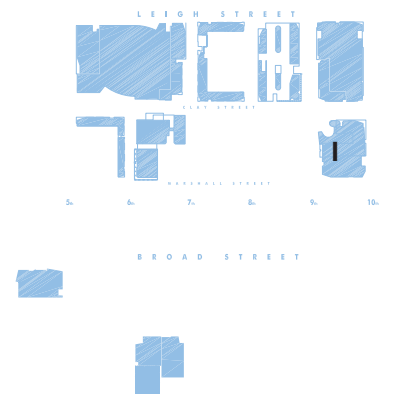
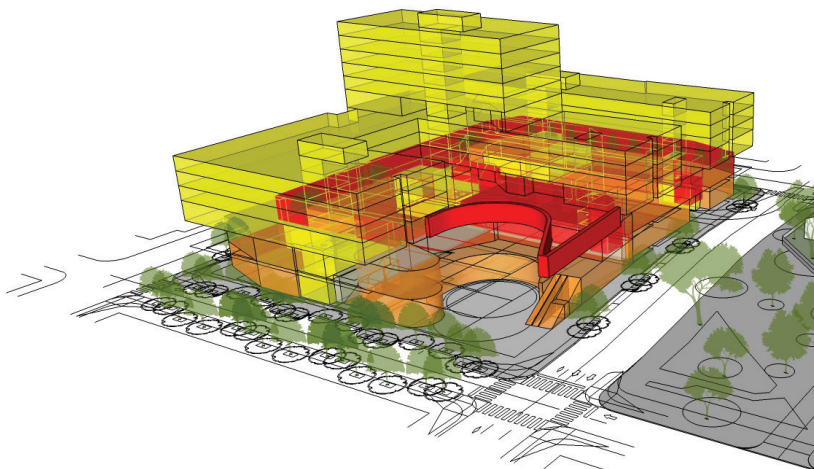

# block N

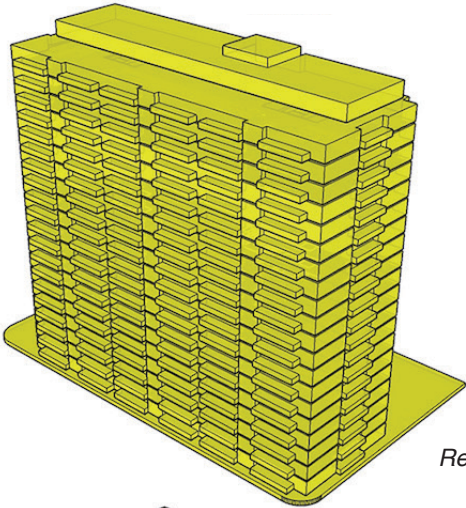

Residential

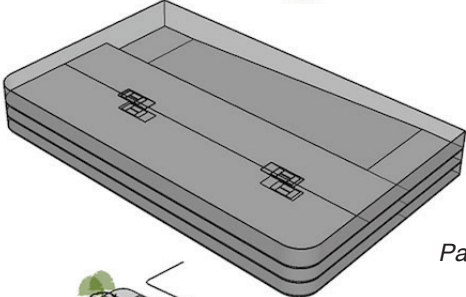

Parking

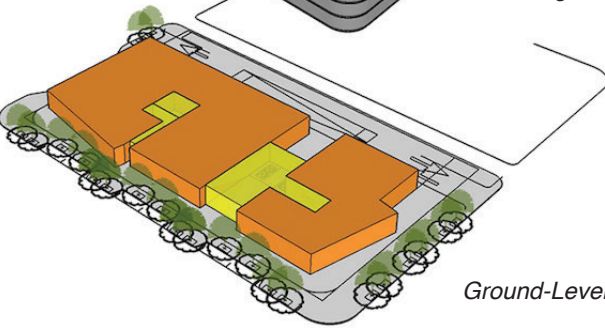

Ground-Level Retail

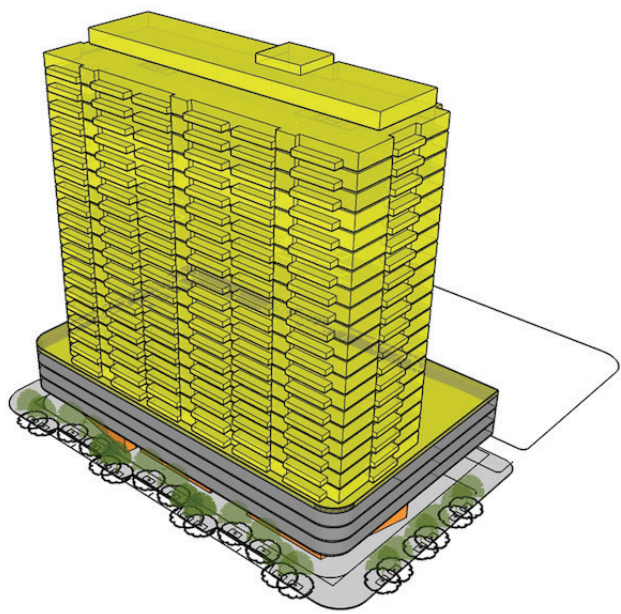

**“N” uses** - Multi-family residential, parking, ground-level retail, and/or office

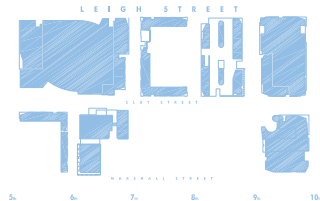

N



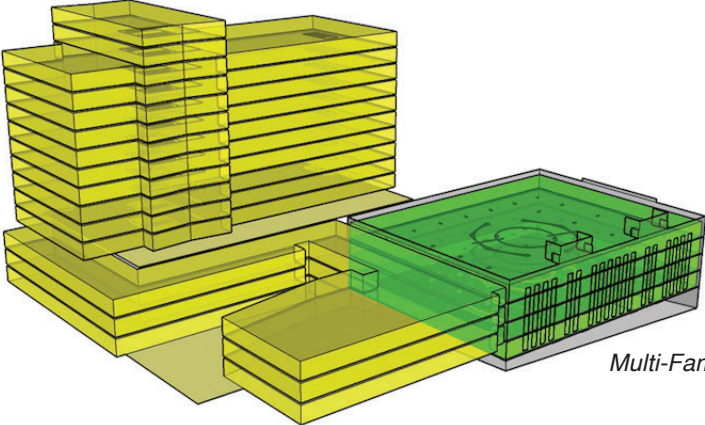

Multi-Family Residential, Hospitality

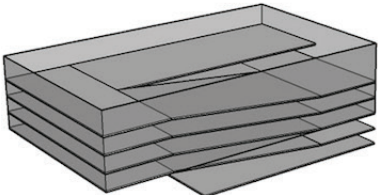

Parking

**“U” uses** - Multi-family residential, hospitality, with ground-level retail and commercial, parking and/or office

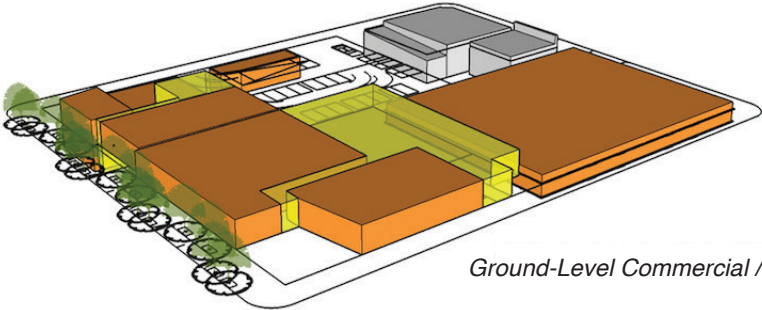

Ground-Level Commercial / Retail

