



# Commission of Architectural Review SUBMISSION APPLICATION

City of Richmond, Room 510 – City Hall  
900 East Broad Street, Richmond, Virginia 23219  
PHONE: (804) 646-6335 FAX: (804) 646-5789

12 COPIES OF SUPPORTING DOCUMENTATION ARE REQUIRED FOR PROCESSING YOUR SUBMISSION

LOCATION OF WORK: 2723 W. Grace St

DATE: 9/29/14

OWNER'S NAME: Chelsea Stipe + Marko Yurachek

TEL NO.: 267-265-4832

AND ADDRESS: 2723 W. Grace St

EMAIL: chelseastipe@gmail.com

CITY, STATE AND ZIPCODE Richmond, VA 23220

ARCHITECT/CONTRACTOR'S NAME: Window Universe

TEL. NO. 866-805-2720

AND ADDRESS: 3108 N. Parham Rd

EMAIL: info@thefutureofreplacementwin  
dows.com

CITY, STATE AND ZIPCODE Richmond, VA 23294

Would you like to receive your staff report via email? Yes  No

### REQUEST FOR CONCEPTUAL REVIEW

I hereby request Conceptual Review under the provisions of Chapter 114, Article IX, Division 4, Section 114-930.6(d) of the Richmond City Code for the proposal outlined below in accordance with materials accompanying this application. I understand that conceptual review is advisory only.

### APPLICATION FOR CERTIFICATE OF APPROPRIATENESS

I hereby make application for the issuance of a certificate under the provisions of Chapter 114, Article IX, Division 4 (Old and Historic Districts) of the Richmond City Code for the proposal outlined below in accordance with plans and specifications accompanying this application.

### DETAILED DESCRIPTION OF PROPOSED WORK (Required):

#### STATE HOW THE DESIGN REVIEW GUIDELINES INFORM THE DESIGN OF THE WORK

**PROPOSED.** (Include additional sheets of description if necessary, and 12 copies of artwork helpful in describing the project. The 12 copies are not required if the project is being reviewed for an administrative approval. See instruction sheet for requirements.)

*See attached description*

Signature of Owner or Authorized Agent:  

Name of Owner or Authorized Agent (please print legibly): Chelsea Stipe

**(Space below for staff use only)**

Received by Commission Secretary

APPLICATION NO. \_\_\_\_\_

DATE \_\_\_\_\_

SCHEDULED FOR \_\_\_\_\_

Note: CAR reviews all applications on a case-by-case basis.

Commission of Architectural Review Submission Application  
Re: Approval for Replacement Windows  
2723 W. Grace St Richmond, VA 23220

Chelsea Stipe and Marko Yurachek, the owners of above property, are requesting permission to install/replace several windows on the home. Of these windows, most are not original, some windows are completely missing, and each have damage or are in disrepair to varying degrees. We would also like to repair a boarded up side entrance and replace a second-story doorway.

**Front of the Building:**

- Lower Left: original window, sunken sill allows for water to collect, not drain properly, window does not open, weight cords are missing, rotted wood at base of window, drafty
  - Requesting to replace window
- Lower Right: original window, cracked glass in upper pane, window does not open, weight cords are missing, rotted wood at base of window, drafty
  - Requesting to replace window

**East Side of the Building:**

- Lower Level Bathroom: boarded up, no serviceable window
  - Requesting to install window
- Basement: boarded up, no serviceable window
  - Requesting to install window
- Lower Entry Doorway: boarded up door and window, not serviceable
  - Requesting to repair doorway and make functional, install window above door

**West Side of the Building:**

- Lower Level Hallway: boarded up, no serviceable window
  - Requesting to install window
- Upper Level Hallway: boarded up, no serviceable window
  - Requesting to install window

**Rear of the Building:**

- Lower Left: not original window, window does not open, drafty
  - Requesting to replace window
- Lower Right: not original window, window does not open, drafty
  - Requesting to replace window and repair space where window and brick meet
- Upper Left Door: does not open and is in disrepair
  - Requesting to replace and eventually make serviceable. We plan to install a fire escape and/or porch for this second-story doorway to provide ground access. We are not submitting a proposal for the fire escape/porch project at this time, but wish to replace/repair this doorway as a part of our current window project.
- Basement: boarded up, no serviceable window
  - Requesting to install window

If there are any questions about this proposal, please feel free to contact either of us. Thank you for your consideration.

Chelsea Stipe  
chelseastipe@gmail.com  
267-265-4832

Marko Yurachek  
myurachek@yahoo.com  
907-590-9715



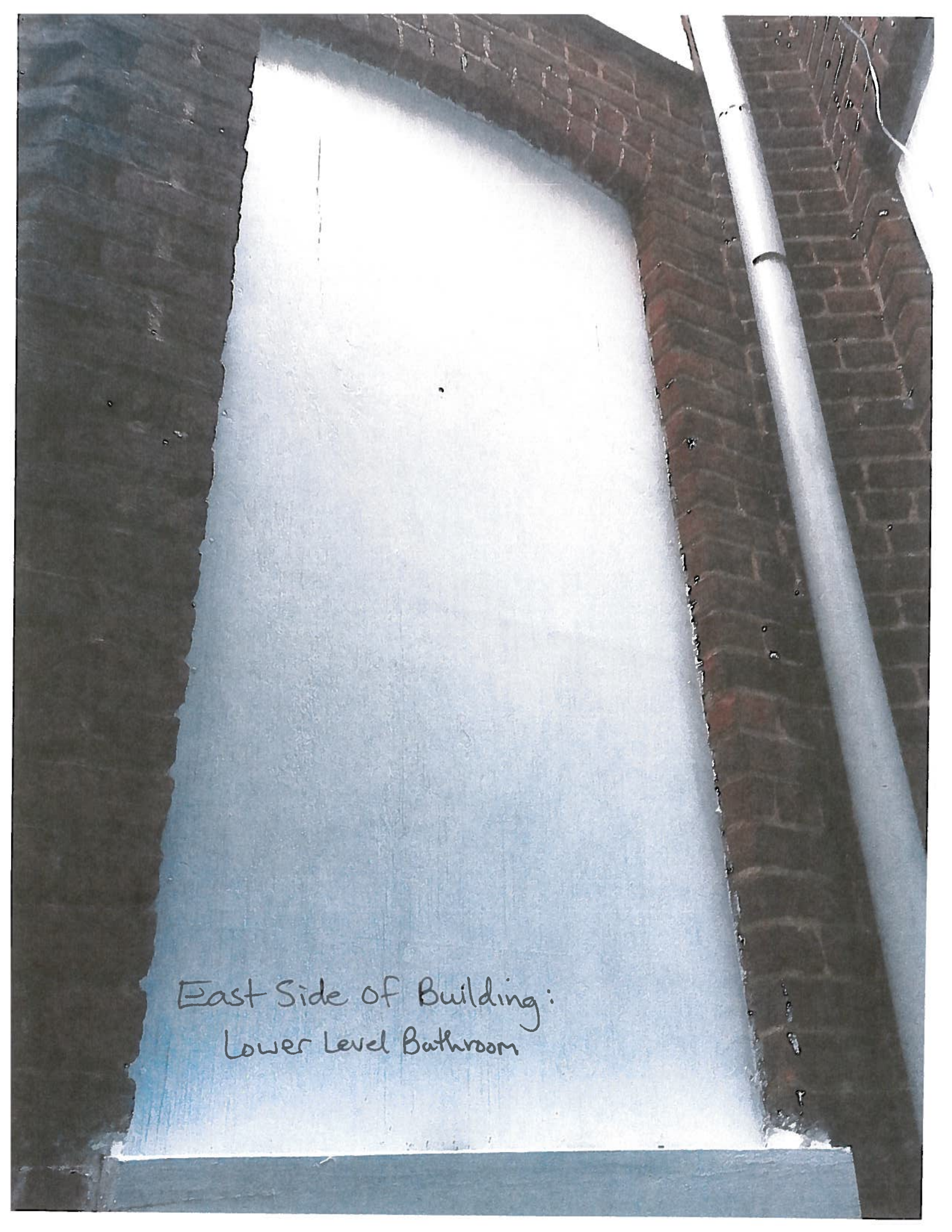

East Side of Building:  
Lower Level Bathroom

East Side of Building: Basement

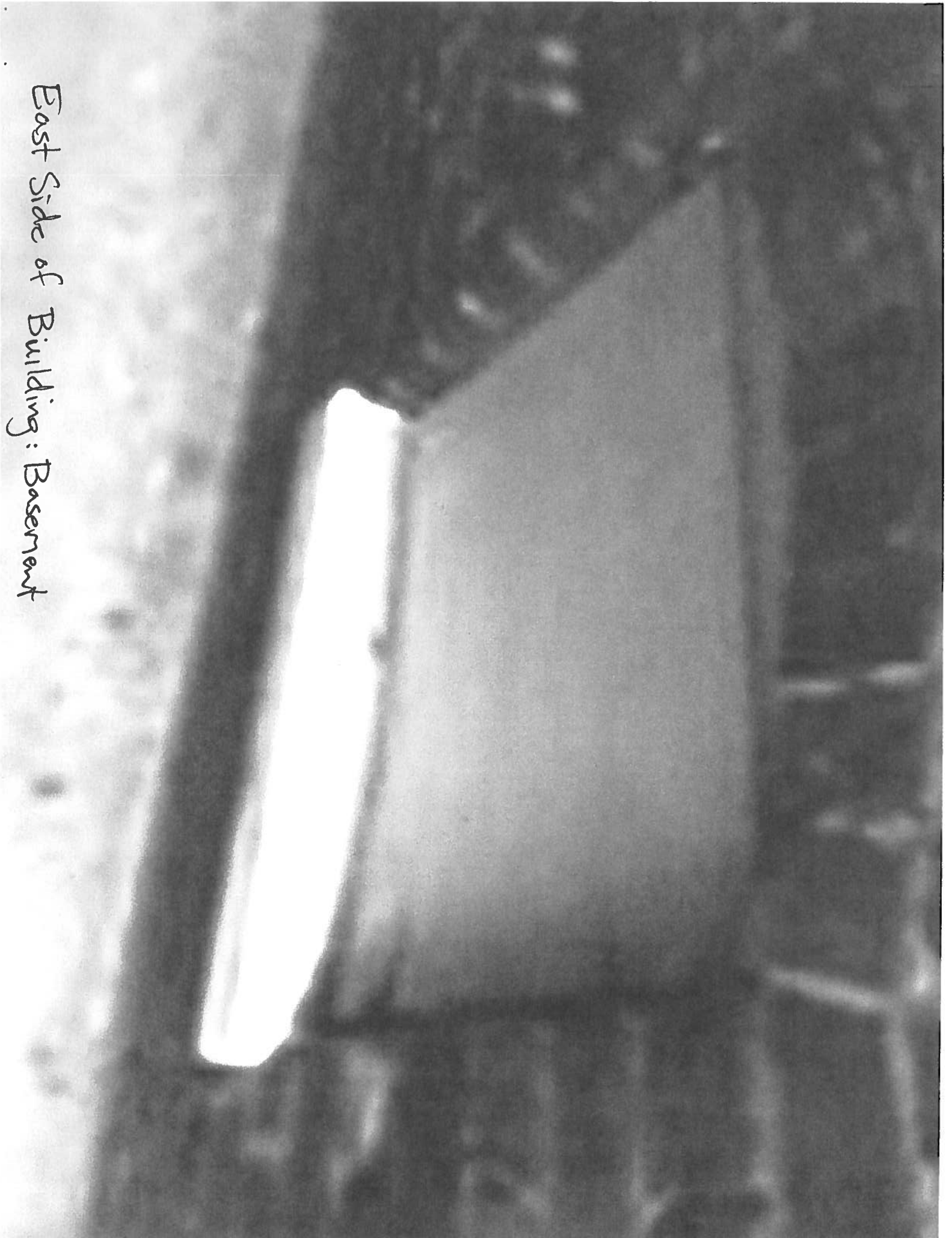



East Side of Building: Doorway

West Side of Building : Lower Level Hallway





PRIVATE  
PARKING  
NO TRESPASSING

Basement

AJ Bennett  
Window Universe  
[www.TheFutureOfReplacementWindows.com](http://www.TheFutureOfReplacementWindows.com)

Siding Universe  
[www.SimpleSmarterSiding.com](http://www.SimpleSmarterSiding.com)

571.408.3858

Find Window Universe on Facebook at [www.Facebook.com/WindowUniverse](http://www.Facebook.com/WindowUniverse)

**3 Time Angie's List  
Super Service Award Winner!**



**Window Universe**  
*www.TheFutureOfReplacementWindows.com*

**Siding Universe**  
*www.SimpleSmarterSiding.com*

 Please don't print this e-mail unless it's necessary. Go Green

## DOUBLE HUNG

Double hung windows create a fresh appearance while simplifying the upkeep of your home. The refined detailing of the five-profile sash and maintainable convex casual elegance with crisp corners and traditional appeal while the integrated energy-saving construction protects your home with a strong and durable shield.

A widely popular choice, double hung windows are especially notable for their easy-care, easy-clean functionality. No need to struggle with ladders to reach the exterior glass. Both sashes tilt in to allow convenient cleaning of the window from inside your home.



Combined with Carwood interior vinyl/plastic finish and contoured grids in a top-only Colonial pattern for custom beauty.

Photo may show product and accessories as suggested. © 2011, All rights reserved. All other trademarks are the property of their respective owners.

- Fusion-welded maintenance and sash corners increase strength and create a clean, neat appearance.
- High-performance insulated glass unit with double-strength glass and warm-edge spacer system increases energy efficiency and longevity.

- Integrated multi-chambered construction provides insulating air spaces for increased energy efficiency and durability.
- Sash-to-sill nested interlock increases strength to prevent the sash from bowing in extreme winds.
- Non-conductive, composite reinforcement in the meeting rails improves energy efficiency and allows for secure mounting of hardware.
- True sloped sill drains water quickly to the exterior to help prevent build up of moisture or debris.
- Duralift™ black and tackle balance system ensures years of easy, smooth operation of the sashes.
- Hidden screen track creates a clean-line appearance for enhanced aesthetic appeal.



Double hung windows are easy to clean! Both sashes tilt in. All convenient access from inside your home.



## BIRKSHIRE ELLI

FOR THE GREEN HOME AND THE GREEN WORLD

Exceptional craftsmanship and sustainable energy. Smart performance. Birkshire Elite is everything you've hoped for in a quality replacement window - and more. The upscale design and attention to detail combine with our advanced technology for efficient, healthy, energy-efficient energy-efficient and excellent value.

### VALUE-ADDED ADVANTAGES

Eye-catching curb appeal, increased energy efficiency and minimal maintenance are three strong amenities that can improve the value of your home. Beautiful, quality-crafted replacement windows will enhance your home's exterior as well as the interior decor. In most cases, you can expect to recover more than half of the cost of your replacement windows when it's time to sell.

### A HEALTHIER PLANET, A STRONGER WORLD

Conserving energy, reducing waste and recycling materials are just a few ways we can all work together to leave a smaller environmental footprint. As good neighbors to each other and the earth, today's homeowners are happily choosing green.

Reverse proudly offers a wide variety of eco-friendly products. Our Birkshire Elite windows are precision-engineered to deliver superior energy efficiency and help reduce the consumption of fossil fuels needed for heating and cooling homes. As a recyclable material, all in-plant vinyl scrap is reused for other products, further reducing the volume and environmental impact of waste. Vinyl windows and patio doors also boast a long service life and typically weigh less than other substrate window products, requiring less energy consumption during transportation.

\*The national average of the cost to replace an end replacement window is over \$700. See [www.reverse.com](http://www.reverse.com) for more information. © 2013 Reverse. All rights reserved. The vinyl window is a registered trademark of Reverse and the Reverse Elite Company.



## **Commission of Architectural Review Submission Application**

Re: Approval for Replacement Windows

2723 W. Grace St Richmond, VA 23220

Chelsea Stipe and Marko Yurachek, the owners of above property, are requesting permission to install/replace several windows on the home. Of these windows, most are not original, some windows are completely missing, and each have damage or are in disrepair to varying degrees. We would also like to repair a boarded up side entrance and replace a second-story doorway.

### **Front of the Building:**

- Lower Left: original window, sunken sill allows for water to collect, not drain properly, window does not open, weight cords are missing, rotted wood at base of window, drafty
  - Requesting to replace window
- Lower Right: original window, cracked glass in upper pane, window does not open, weight cords are missing, rotted wood at base of window, drafty
  - Requesting to replace window

### **East Side of the Building:**

- Lower Level Bathroom: boarded up, no serviceable window
  - Requesting to install window
- Basement: boarded up, no serviceable window
  - Requesting to install window
- Lower Entry Doorway: boarded up door and window, not serviceable
  - Requesting to repair doorway and make functional, install window above door

### **West Side of the Building:**

- Lower Level Hallway: boarded up, no serviceable window
  - Requesting to install window
- Upper Level Hallway: boarded up, no serviceable window
  - Requesting to install window

### **Rear of the Building:**

- Lower Left: not original window, window does not open, drafty
  - Requesting to replace window
- Lower Right: not original window, window does not open, drafty
  - Requesting to replace window and repair space where window and brick meet
- Upper Left Door: does not open and is in disrepair
  - Requesting to replace and eventually make serviceable. We plan to install a fire escape and/or porch for this second-story doorway to provide ground access. We are not submitting a proposal for the fire escape/porch project at this time, but wish to replace/repair this doorway as a part of our current window project.
- Basement: boarded up, no serviceable window
  - Requesting to install window

Please see the enclosed materials insert from The Window Universe. The windows are vinyl, double hung, and do not have grids. Regarding the wood framing of the windows, Window Universe usually caps over the exterior framing of the window opening. They can also use a “blind-stop” capping if necessary to simply seal the window in and protect from the elements.

If there are any questions about this proposal, please feel free to contact either of us. Thank you for your consideration.

Chelsea Stipe  
chelseastipe@gmail.com  
267-265-4832

Marko Yurachek  
myurachek@yahoo.com  
907-590-9715

**110% Best Value Guaranteed!**

# Window Universe

www.TheFutureofReplacementWindows.com



## Addendum A - Build Your Window & Patio Door Quote

Customer Name: Marco Yurachek

Quote Guaranteed Until: \_\_\_\_\_

Initial: \_\_\_\_\_

### STEP 1: SELECT YOUR WINDOWS

Single Hung	\$ 188	
<u>6</u> Double Hung	\$ 204	<u>1224</u>
Hopper	\$ 190	
2 Lite Slider	\$ 329	
3 Lite Slider	\$ 520	
<u>1/4-1/2-1/4</u> or <u>Equal-Lite</u>		
Casement or Awning	\$ 250	
Twin Casement	\$ 500	
3 Lite Casement	\$ 750	
Picture Window	\$ 329	
Garden Window	\$ 1,750	
Bay Window	\$ 2,100	
Bow Window - <u>4</u> , <u>5</u> or <u>6</u> Lite	\$ 2,450	
See worksheet for additional details		
Specialty Window _____		

### STEP 2: CHOOSE WINDOW COLORS

<u>6</u> White		<u>Standard</u>
Almond / Beige	\$ 32	
White Woodgrain Interior	\$ 65	
Beige Exterior Required		
Woodgrain Interior _____	\$ 95	
Designer's Collection Color _____	\$ 125	
Full Screen Required		

*Most, but not all combinations are available. Ask me for details.*

### STEP 3: SELECT GLASS OPTIONS

<u>6</u> Mid-Atlantic Barrier Glass Package	\$ 59	<u>354</u>
Low - E Glass & Argon Gas Filled		
SustainaView Glass Upgrade	\$ 32	
The Industry's Most Advanced Spacer Option		
Available Upgrade _____		
Radiant Barrier Glass Upgrade	\$ 37	
Extra Protection For Very High Sun Areas		
Available Upgrade _____		
Clean & Clear Glass Upgrade	\$ 29	
Windows Stay Clean With Hydrophilicity		
Available Upgrade _____		
Triple Pane Upgrade	\$ 99	
Includes upgrade to triple pane frame		
Available Upgrade _____		

*U-Factors as low as 0.18 available. Ask me how.*

### STEP 4: PICK WINDOW OPTIONS

Upgraded Balance System		Standard
Foam Insulated Frame		Standard
Metal Reinforced Sashes		Standard
Full Screen - Half Screen Standard	\$ 22	
Double Strength Glass		Standard
Extruded Screen Frame		Standard
Grids - <u>Flat</u> or <u>Contoured</u>	\$ 39	
Knife Edge Sash Interlock		Standard
High Strength Laminated Glass	\$ 199	

### STEP 5: INCLUDE PATIO DOORS

5' or 6' Sliding Glass Door	\$ 1,200	
8' Sliding Glass Door	\$ 1,450	
9' Sliding Glass Door	\$ 1,700	
12' Sliding Glass Door	\$ 1,950	

### STEP 6: PICK PATIO DOOR COLORS

White		Standard
Almond / Beige	\$ 199	
White Woodgrain Interior	\$ 95	
Beige Exterior Only		
Woodgrain Interior _____	\$ 125	
Designer's Collection Color _____	\$ 499	

*Most, but not all combinations are available. Ask me for details.*

### STEP 7: DECIDE ON PATIO DOOR OPTIONS

*Glass options are all priced per panel*

Mid-Atlantic Barrier Glass Package	\$ 65	
Low - E Glass & Argon Gas Filled		

SustainaView Glass Upgrade	\$ 47	
Radiant Barrier Glass Upgrade	\$ 51	
Clean & Clear Glass Upgrade	\$ 44	
Triple Pane Barrier Package	\$ 99	

*There are many more glass options available. Ask me for details.*

Professional Installation Including

Custom Exterior Trim _____	\$ 150	
Grids - <u>Flat</u> or <u>Contoured</u>	\$ 100	
Prairie Grids - <u>Single</u> or <u>Double</u>	\$ 199	
Exterior Key Lock	\$ 35	
Interior Foot Lock	\$ 25	
Interior Custom Handle	\$ 49	

Bright or Antique Brass, Bright or Brushed Chrome

### STEP 8: ADD ADDITIONAL ITEMS

Professional Installation Including		
<u>6</u> Custom Exterior Trim <u>White</u>	\$ 65	<u>390</u>
Remove and Replace Existing Bars	\$ 120	
<u>3</u> Storm Window Removal	\$ 12	<u>36</u>
Metal / Vinyl Removal	\$ 60	
Remove Mull	\$ 35	
Mull to Form Multi Unit	\$ 35	
Tempered Glass Per Sash	\$ 70	
Tempered Glass Other - per sq foot	\$ 12.00	
Install New Interior Trim - per foot	\$ 6.50	
<u>2</u> Repair Sill or Jamb	\$ 75	<u>75</u>
Replace Sill	\$ 150	
Obscure Glass Per Sash	\$ 35	
Lifetime Labor Warranty		Standard
Lifetime Glass Breakage Warranty		Standard
<u>1</u> Site Setup & Disposal Fee	\$ 175	<u>175</u>

YOU'RE DONE! TOTAL PROJECT COST \$ ~~2554~~ 2254

Window Universe, LLC is not responsible for removal of window treatments, AC units or furniture. Painting, staining and alarm systems are the responsibility of the homeowner. Unexpected issues found during installation will require repair at rates listed on this agreement. I have read and agree to the terms and conditions stated here and on both sides of the contract.

*[Signature]*

**Jennifer Mattern**

---

**From:** Kayla Edelin [KEdelin@thefutureofreplacementwindows.com]  
**Sent:** Tuesday, April 08, 2014 10:05 AM  
**To:** 'Jennifer Mattern'  
**Subject:** FW: WINDOW UNIVERSE

8 WINDOWS

---

**From:** AJ Bennett [mailto:ABennett@TheFutureOfReplacementWindows.com]  
**Sent:** Monday, April 7, 2014 4:41 PM  
**To:** Kayla Edelin  
**Subject:** Fwd: WINDOW UNIVERSE

Sent from my iPhone

Begin forwarded message:

**From:** Marko Yurachek <myurachek@yahoo.com>  
**Date:** April 7, 2014 at 4:04:01 PM EDT  
**To:** abennett@thefutureofreplacementwindows.com  
**Cc:** Chelsea Stipe <chelseastipe@gmail.com>  
**Subject:** Fwd: WINDOW UNIVERSE

Hey AJ

The window list that you sent Chelsea is good, the new one that is.  
That is what we agreed on before we left. Go ahead and get it started.

Thanks,

Marco

907-590-9715

--- On Mon, 4/7/14, Chelsea Stipe <chelseastipe@gmail.com> wrote:

From: Chelsea Stipe <chelseastipe@gmail.com>

Subject: Fwd: WINDOW UNIVERSE

To: "Marco" <myurachek@yahoo.com>

Date: Monday, April 7, 2014, 5:15 AM

See AJ's message. I

don't know what you have talked with him about, but he  
sent this message to me on March 31st.

----- Forwarded

message -----

From: <abennett@thefutureofreplacementwindows.com>

Date: Mon, Mar 31, 2014 at 1:49 PM  
Subject: WINDOW UNIVERSE  
To: Chelsea Stipe <[chelseastipe@gmail.com](mailto:chelseastipe@gmail.com)>

Chelsea,  
I am trying to get confirmation for the additional windows and modifications to existing windows.

We had  
measured:  
Living Room – 2  
DH  
Rear – 2  
DH Side – 1  
DH Alley – 1  
PW  
2nd Fl – 1  
DH 2nd Fl – 1  
PW

Which will now be:

~~Living Room – 2~~  
~~DH Rear – 2~~  
DH  
~~Side – 1 DH Alley~~  
~~– 1 Hopper 2nd Fl – 1~~  
DH  
2nd Fl – 1 Hopper <sup>DH</sup>

Which will mean we are adding 2 DH windows to the order. This will add a cost of \$680 to the total project. Please confirm the locations and styles.

Sales Person:



Customer Name:  
RW1240WINDOW UNIVERSE

Customer Number:

Bill To:

Ship To:

Order Notes:

Delivery Notes:

Phone: (866) 805-2

Quote Name:

STIPE, CHELSEA

QUOTE #	RUSH	STATUS
364436	No	None

Line Item #	Qty	Width x Height	Description
-------------	-----	----------------	-------------

1-1 2 33.75" X 70"

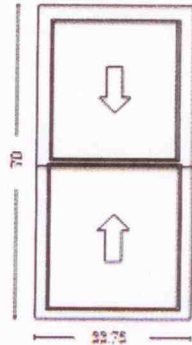

3001-BerkShire Elite Double Hung 33.75 x 70  
 Sash Split = Even  
 Operation / Venting = Double Hung  
 Frame Strength = Standard Composite Frame  
 Frame Color = White  
 Barrier XP, No Upgrade  
 Foam Wrap, Header Expander, Brickmould = No Brickmould

Line Item Notes:

Comment / Room:

Line 1

Line Item #	Qty	Width x Height	Description
-------------	-----	----------------	-------------

2-1 2 31.75" X 61.5"

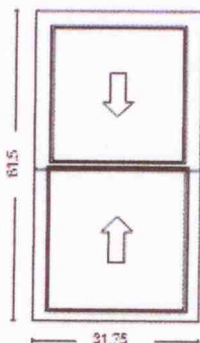

3001-BerkShire Elite Double Hung 31.75 x 61.5  
 Sash Split = Even  
 Operation / Venting = Double Hung  
 Frame Strength = Standard Composite Frame  
 Frame Color = White  
 Barrier XP, No Upgrade  
 Foam Wrap, Header Expander, Brickmould = No Brickmould

Line Item Notes:

Comment / Room:

Line 2

QUOTE #	RUSH	STATUS
364436	No	None

Line Item #	Qty	Width x Height	Description
-------------	-----	----------------	-------------

3-1 1 33.75" X 78"

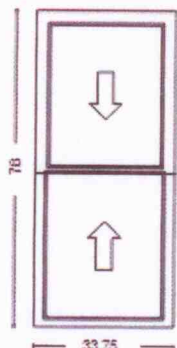

3001-BerkShire Elite Double Hung 33.75 x 78  
 Sash Split = Even  
 Operation / Venting = Double Hung  
 Frame Strength = Standard Composite Frame  
 Frame Color = White  
 Barrier XP, No Upgrade  
 Foam Wrap, Header Expander, Brickmould = No Brickmould  
**Line Item Notes:**

Comment / Room:

Line 3

Line Item #	Qty	Width x Height	Description
-------------	-----	----------------	-------------

4-1 1 28.75" X 29"

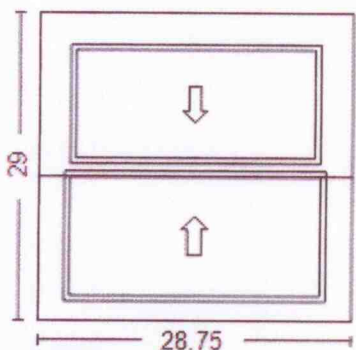

3001-BerkShire Elite Double Hung 28.75 x 29  
 Sash Split = Even  
 Operation / Venting = Double Hung  
 Frame Strength = Standard Composite Frame  
 Frame Color = White  
 Barrier XP, No Upgrade  
 Foam Wrap, Header Expander, Brickmould = No Brickmould  
**Line Item Notes:**

Comment / Room:

Line 4

Line Item #	Qty	Width x Height	Description
-------------	-----	----------------	-------------

5-1 1 32.75" X 70"

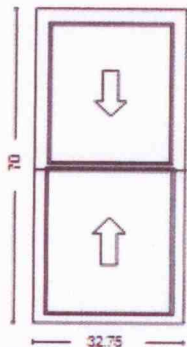

3001-BerkShire Elite Double Hung 32.75 x 70  
 Sash Split = Even  
 Operation / Venting = Double Hung  
 Frame Strength = Standard Composite Frame  
 Frame Color = White  
 Barrier XP, No Upgrade  
 Foam Wrap, Header Expander, Brickmould = No Brickmould  
**Line Item Notes:**

Comment / Room:

Line 5

QUOTE #	RUSH	STATUS	
364436	No	None	
Line Item #	Qty	Width x Height	Description

6-1      1      28" X 28"

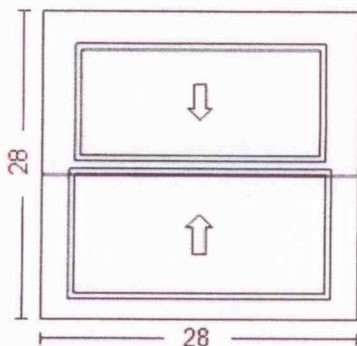

3001-BerkShire Elite Double Hung 28 x 28  
 Sash Split = Even ✓  
 Operation / Venting = Double Hung ✓  
 Frame Strength = Standard Composite Frame ✓  
 Frame Color = White ✓  
 Barrier XP, No Upgrade ✓  
 Foam Wrap, Header Expander, Brickmould = No Brickmould

**Line Item Notes:**

Comment / Room:

Line 6

Thank you for your order. Please review this quote, and confirm that all details are correct by signing below. Since these products will be custom made to your specifications, it is noncancellable, nonreturnable, and nonrefundable. Actual tax will be calculated when your order is invoiced. Tax may vary slightly from what is displayed on the quote. All quoted pricing will be honored for 30 days, unless otherwise stated.

*Jennifer Matto*

Authorized Representative

*JASON*