



**City of Richmond
Department of Planning
and Development Review**

**Urban Design Committee
Encroachment**

Address: 123 W. Broad Street

Council District: 2

Description: Encroachment of outdoor patio with railing on ROW.

For questions, please contact Alex Dandridge at (804)-646-6569 or alex.dandridge@rva.gov

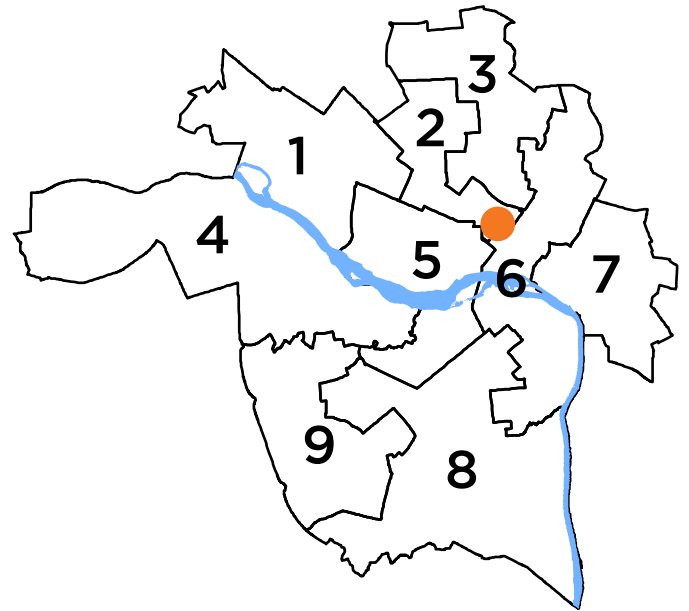



Application for Urban Design Committee Review

Department of Planning and Development Review

Planning & Preservation Division

900 E. Broad Street, Room 510

Richmond, Virginia 23219 | (804) 646-6335

<https://www.rva.gov/planning-development-review/urban-design-committee>



Application Type (select one)

Location, Character, & Extent
Section 17.05
Other:

Encroachment
Design Overlay District

Review Type (select one)

Conceptual
Final

Project Information

Submission Date: _____

Project Name: _____

Project Address: _____

Brief Project Description (this is not a replacement for the required detailed narrative):

Applicant Information (a City representative must be the applicant, with an exception for encroachments)

Name: _____ Email: _____

City Agency: _____ Phone: _____

Main Contact (if different from Applicant): _____

Company: _____ Phone: _____

Email: _____

Submittal Deadlines

All applications and support materials must be filed no later than 21 days prior to the scheduled meeting of the Urban Design Committee (UDC). Please see the schedule on page 3 as actual deadlines are adjusted due to City holidays. **Late or incomplete submissions will be deferred to the next meeting.**

Filing

Applications can be mailed or delivered to the attention of "Urban Design Committee" at the address listed at the top of this page. **It is important that the applicant discuss the proposal with appropriate City agencies, Zoning Administration staff, and area civic associations and residents prior to filing the application with the UDC.**

Submittal Deadlines

The UDC is an 11 member committee created by City Council in 1968 whose purpose is to advise the City Planning Commission (CPC) on the design of projects on City property or right-of-way. The UDC provides advice of an aesthetic nature in connection with the performance of the duties of the Commission under Sections 17.05, 17.06, and 17.07 of the City Charter. The UDC also advises the Department of Public Works in regards to private encroachments in the public right-of-way.



Application for Urban Design Committee Review

Department of Planning and Development Review

Planning & Preservation Division

900 E. Broad Street, Room 510

Richmond, Virginia 23219 | (804) 646-6335

<https://www.rva.gov/planning-development-review/urban-design-committee>



Submission Requirements

- An electronic copy (PDF preferred) of all application materials, which can be emailed, or delivered by FTP or USB.
- Three (3) copies of the application cover sheet and all support materials (see below).
- Plan sheets should be 11" x 17", folded to 8 1/2" x 11". If it is not possible to scale plans to these dimensions, please provide one set of larger, scaled plans.
- All applications must include the attached cover sheet and the following support materials, as applicable to the project, based on Review Type:

Conceptual Review:

- A detailed project narrative which includes the following: purpose of the project, project background, project budget and funding sources, description of construction program and estimated construction start date (description should also provide information on the surrounding area to provide context).
- A site plan for the project indicating site characteristics which include: building footprints, parking areas, pedestrian routes, recreation areas, open areas, and areas of future expansion.
- A set of floor plans and elevations, as detailed as possible.
- A landscaping plan which shows the general location and character of plant materials and notes any existing tree to be removed.

Final Review:

- A detailed project narrative which includes the following: purpose of the project, project background, project budget and funding sources, description of construction program, and estimated construction start date (description should also provide information on the surrounding area to provide context).
- A site plan for the project indicating site characteristics which include: building footprints, parking areas, pedestrian routes, recreation areas, open areas, and areas of future expansion.
- A set of floor plans and elevations, as detailed as possible.
- A landscaping plan that includes a complete plant schedule, the precise location of all plant materials, and a landscape maintenance analysis. The plant schedule must show number, size and type of each planting proposed. If existing trees are to be removed, their size, type, and location must be noted on the landscape plan.
- The location of all lighting units should be noted on a site plan, including wall-mounted, site, and parking lot lighting. Other site details such as benches, trash containers, and special paving materials should also be located. Include specification sheets for each item.
- Samples of all proposed exterior building materials, including but not limited to brick, mortar, shingles, siding, glass, paint, and stain colors. When an actual sample cannot be provided, a product information sheet that shows the item or a photo of an existing item may be substituted.

Review and Processing

- Once an application is received, it is reviewed by Staff, who compiles a report that is sent to the UDC.
- A copy of the report and the meeting agenda will be sent to the applicant prior to the meeting.
- At the UDC meeting, the applicant or a representative should be present or the application may be deferred to the next regularly scheduled meeting. It is also strongly suggested that a representative of the City Agency which will have final responsibility for the item be present at the meeting (if the applicant and the representative are not the same).
- Once the UDC recommends action on the application, it is automatically placed on the agenda for the next City Planning Commission (CPC) meeting. Exceptions to this are encroachment applications, recommendations for which are forwarded to the Department of Public Works.
- At the CPC meeting, the applicant or a representative should be present, or the application may be deferred to the next regularly scheduled meeting.



Application for Urban Design Committee Review

Department of Planning and Development Review
Planning & Preservation Division
900 E. Broad Street, Room 510
Richmond, Virginia 23219 | (804) 646-6335
<https://www.rva.gov/planning-development-review/urban-design-committee>



Regular meetings are scheduled on the Thursday after the first Monday of each month at **10:00 a.m. in the 5th floor conference room of City Hall, 900 E. Broad Street**. Special meetings are scheduled as needed.

Meeting Schedule 2021

UDC Meetings	UDC Submission Deadlines	Anticipated Date of Planning Commission Following the UDC Meeting
December 9, 2021	November 11, 2021	December 21, 2021
January 6, 2022	December 16, 2021	January 18, 2022 ¹
February 10, 2022	January 13, 2022	February 22, 2022 ²
March 10, 2022	February 17, 2022	March 21, 2022
April 7, 2022	March 17, 2022	April 18, 2022
May 5, 2022	April 14, 2022	May 16, 2022
June 9, 2022	May 12, 2022	June 21, 2022
July 7, 2022	June 16, 2022	July 18, 2022
August 4, 2022	July 14, 2022	August 15, 2022 ³
September 8, 2022	August 11, 2022	September 19, 2022
October 6, 2022	September 15, 2022	October 17, 2022
November 10, 2022	October 13, 2022	November 21, 2022
December 8, 2022	November 17, 2022 ⁴	December 19, 2022 ⁵

¹ Monday January 17, 2022 is a City of Richmond Holiday

² Monday February 15, 2022 is a City of Richmond Holiday

³ This meeting is subject to cancellation. If so, Planning Commission hearing would be Tuesday September 7, 2021.

⁴ Thursday November 11, 2022 is a City of Richmond Holiday.

⁵ This meeting of the Planning Commission is subject to cancellation.

The Richmond Urban Design Committee is an 11 member advisory committee created by City Council in 1968. Its purpose is to advise the City Planning Commission on the design of City projects. The Urban Design Committee reviews projects for appropriateness in "location, character, and extent" and for consistency with the City's Master Plan and forwards recommendations to the City Planning Commission. The Urban Design Committee also advises the Department of Public Works in regards to private encroachments in the public right-of-way.

For more information, please contact the Planning and Preservation Division staff at (804) 646-6335 or Alex Dandridge at (804) 646-6569 or at alex.dandridge@richmondgov.com.

Attachment Detail

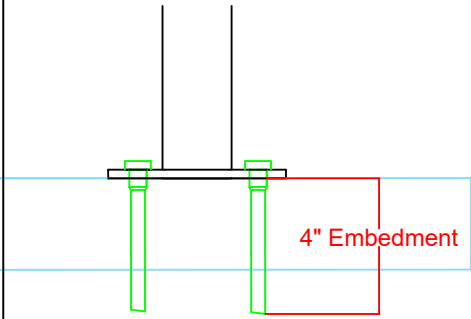

Attachment Method

Post's are to be secured to concrete sidewalk via $\frac{1}{4}$ " by 4" stainless steel Titan Hd concrete anchors.

Two Anchors per post, with a diagonal layout for maximum distance between anchors.

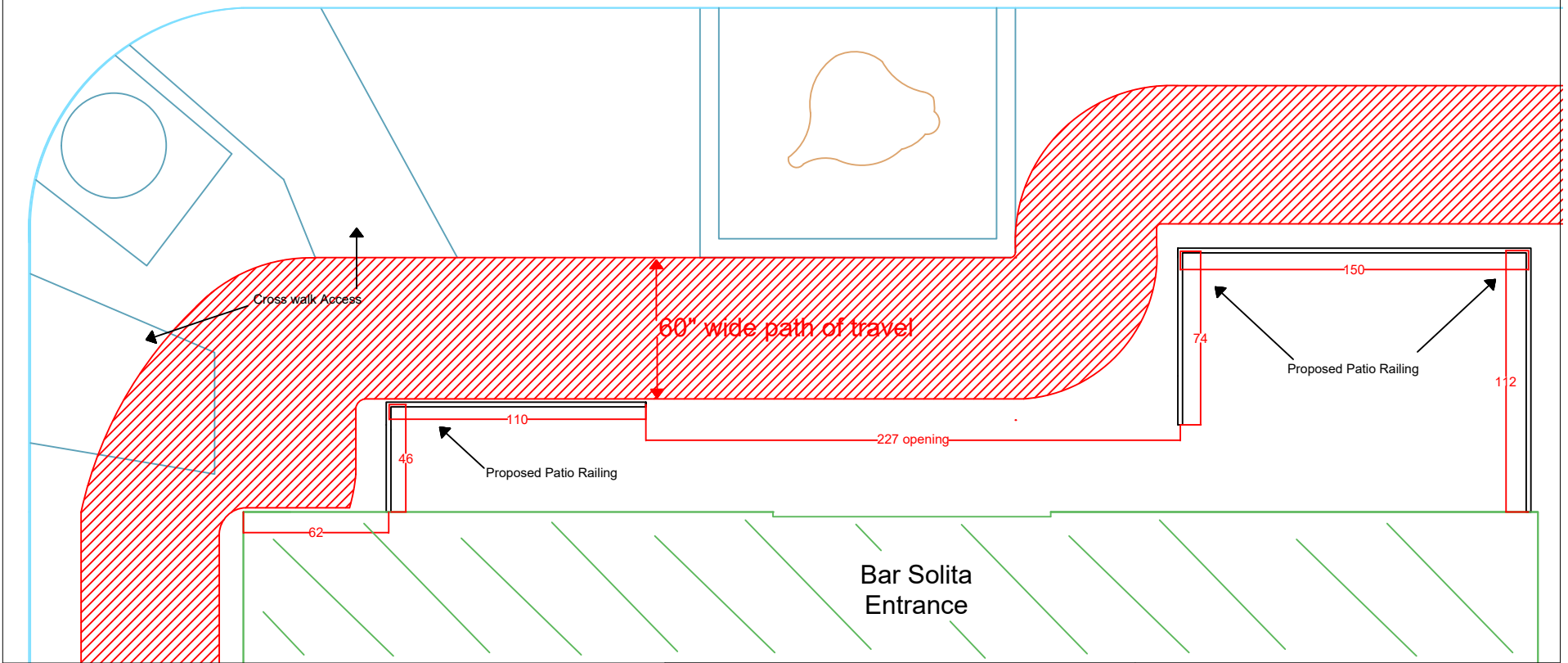

Project Name / Address

Bar Solita - 123 West Broad St.

Project Description

Powdercoated aluminum patio railing



2031 WestWood Ave.
Richmond, VA 23230
(804) 266 2664

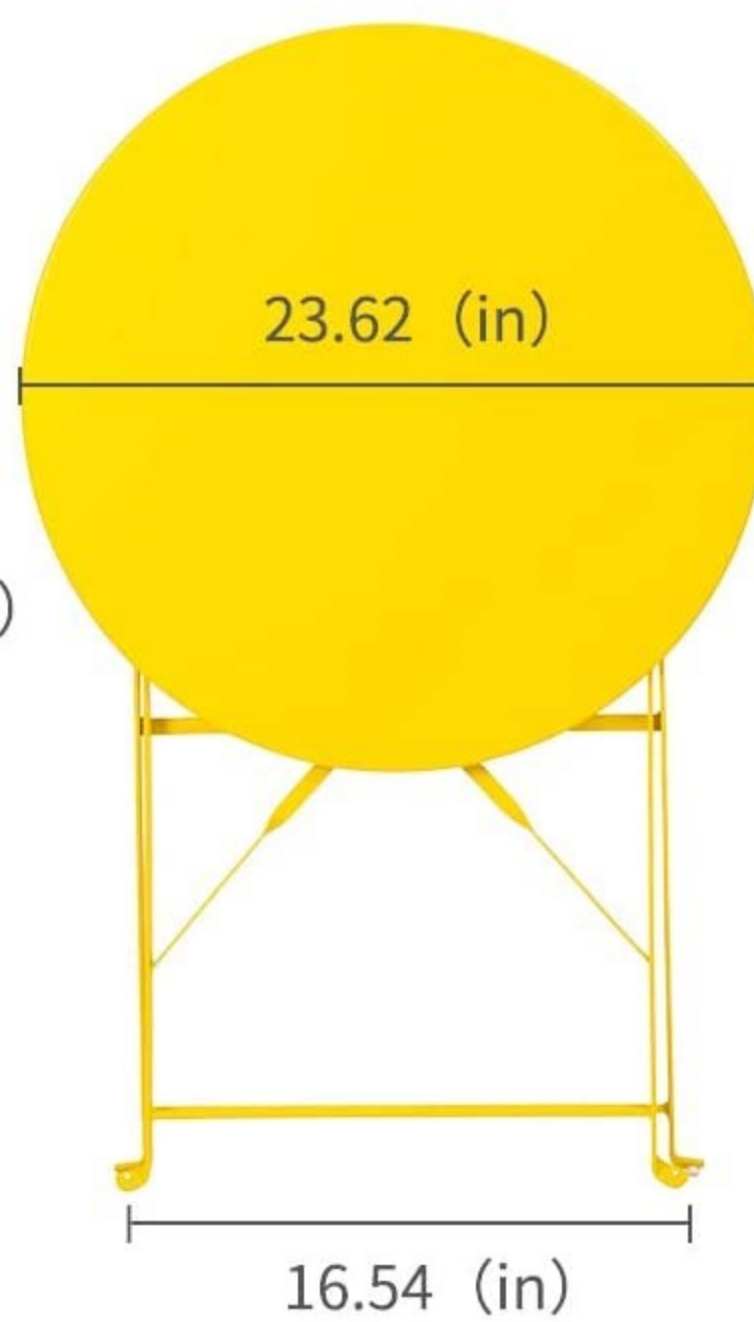
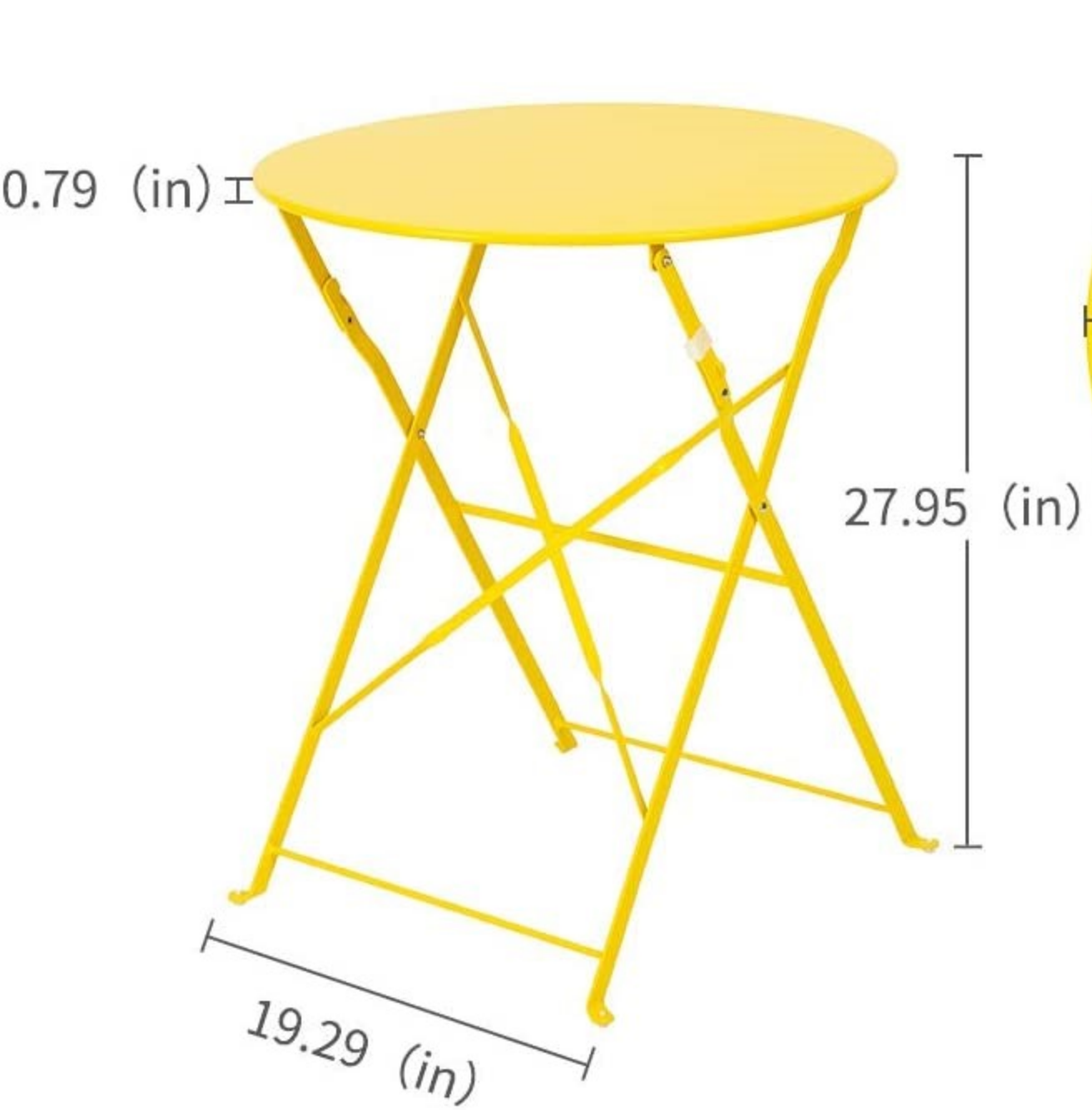
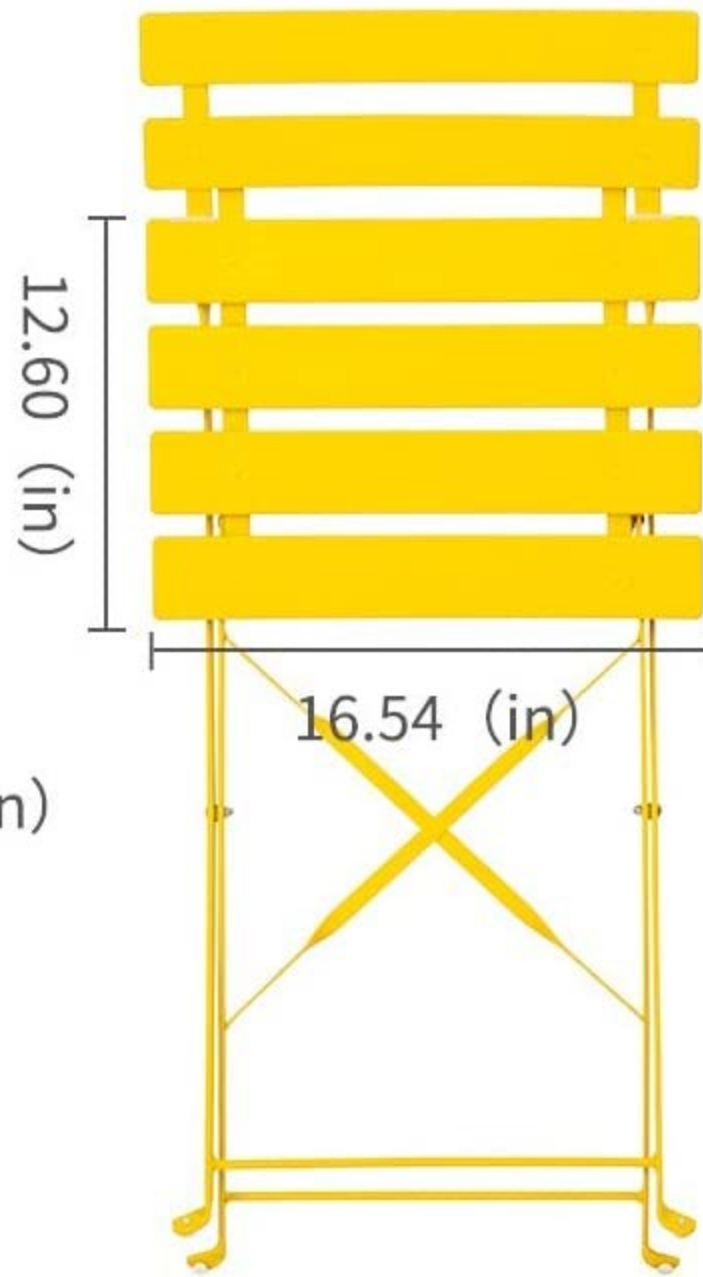
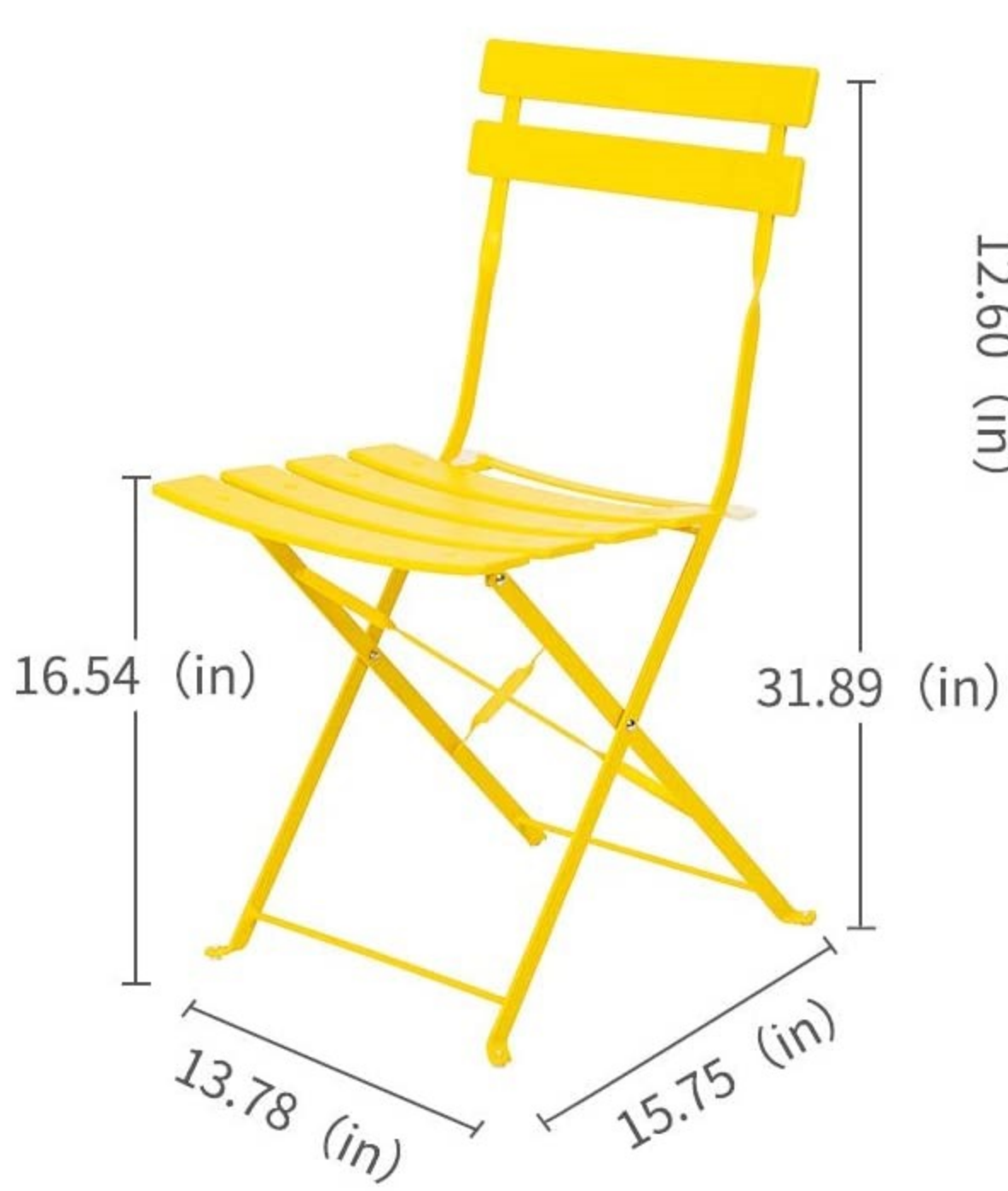

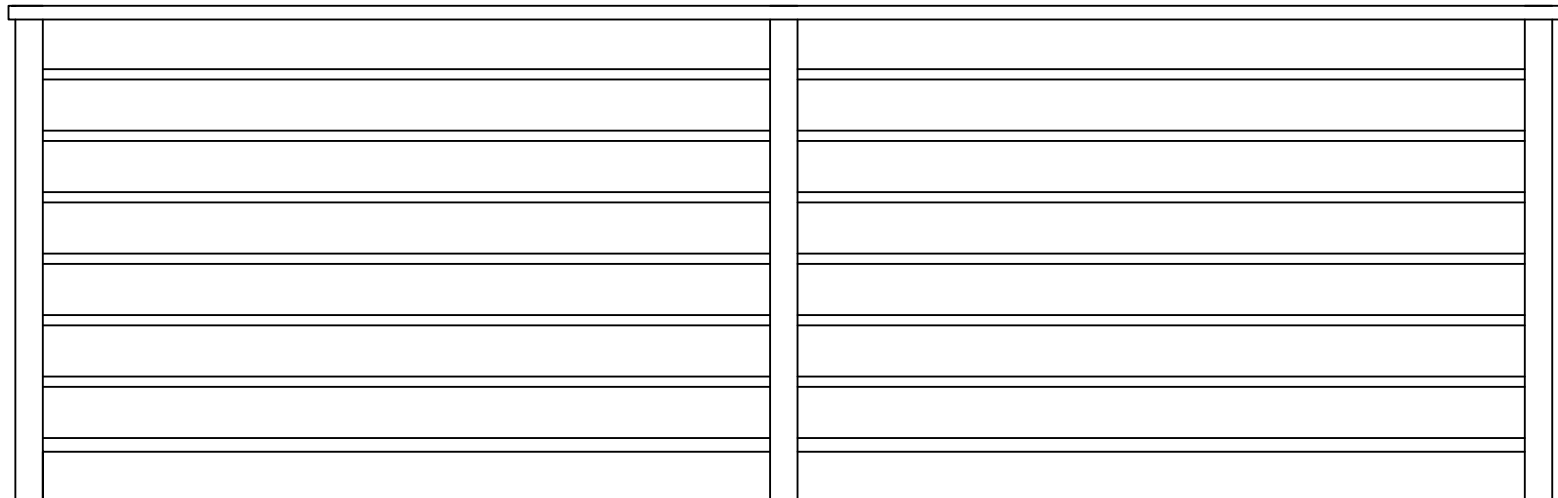

Project Name / Address

123 West Broad St, Richmond VA 23220

Materials

Black Powdercoated Aluminum



2031 WestWood Ave.
Richmond, VA 23230
(804) 266 2664