

INTRODUCED: May 26, 2026

AN ORDINANCE No. 2026-127

To authorize the special use of the property known as 902 North 28th Street for the purpose of up to one single-family detached dwelling and one single-family attached dwelling, upon certain terms and conditions.

Patron – Mayor Avula (By Request)

Approved as to form and legality
by the City Attorney

PUBLIC HEARING: JUN 22 2026 AT 6 P.M.

WHEREAS, the owner of the property known as 902 North 28th Street, which is situated in a R-6 Single-Family Attached Residential District, desires to use such property for the purpose of up to one single-family detached dwelling and one single-family attached dwelling, which use, among other things, is not currently allowed by sections 30-412.4, concerning lot area and width, density, and unit width, and 30-412.5, concerning yards, of the Code of the City of Richmond (2020), as amended; and

WHEREAS, in accordance with section 17.11 of the Charter of the City of Richmond (2020), as amended, it has been made to appear that, if granted subject to the terms and conditions set forth in this ordinance, the special use granted by this ordinance will not be detrimental to the

AYES: _____ NOES: _____ ABSTAIN: _____

ADOPTED: _____ REJECTED: _____ STRICKEN: _____

safety, health, morals and general welfare of the community involved, will not tend to create congestion in streets, roads, alleys and other public ways and places in the area involved, will not create hazards from fire, panic or other dangers, will not tend to overcrowding of land and cause an undue concentration of population, will not adversely affect or interfere with public or private schools, parks, playgrounds, water supplies, sewage disposal, transportation or other public requirements, conveniences and improvements, and will not interfere with adequate light and air; and

WHEREAS, (i) the City Planning Commission has conducted a public hearing to investigate the circumstances and conditions upon which the Council is empowered to authorize such use, (ii) the City Planning Commission has reported to the Council the results of such public hearing and investigation and its recommendations with respect thereto, and (iii) the Council has conducted a public hearing on this ordinance at which the person in interest and all other persons have had an opportunity to be heard;

NOW, THEREFORE,

THE CITY OF RICHMOND HEREBY ORDAINS:

§ 1. **Finding.** Pursuant to section 30-1050.1 of the Code of the City of Richmond (2020), as amended, the Council hereby finds that the special use set forth in and subject to the terms and conditions of this ordinance will not (i) be detrimental to the safety, health, morals and general welfare of the community involved, (ii) tend to create congestion in streets, roads, alleys and other public ways and places in the area involved, (iii) create hazards from fire, panic or other dangers, (iv) tend to overcrowding of land and cause an undue concentration of population, (v) adversely affect or interfere with public or private schools, parks, playgrounds, water supplies,

sewage disposal, transportation or other public requirements, conveniences and improvements, or (vi) interfere with adequate light and air.

§ 2. **Grant of Special Use Permit.**

(a) Subject to the terms and conditions set forth in this ordinance, the property known as 902 North 28th Street and identified as Tax Parcel No: E000-0477/040 in the 2026 records of the City Assessor, being more particularly shown on a survey entitled “Sketch Showing the Proposed Lot Split & Improvements on Lot 2, Block ‘C’, Section ‘1’, ‘East Payne Square’ in the City of Richmond, Va.,” prepared by Virginia Surveys, and dated June 13, 2025, a copy of which is attached to and made a part of this ordinance, hereinafter referred to as “the Property,” is hereby permitted to be used for the purpose of up to one single-family detached dwelling and one single-family attached dwelling, hereinafter referred to as “the Special Use,” substantially as shown on the plans entitled “902 N 28th St.,” prepared by River Mill Development, and dated June 16, 2025, “Sketch Showing the Proposed Lot Split & Improvements on Lot 2, Block ‘C’, Section ‘1’, ‘East Payne Square’ in the City of Richmond, Va.,” prepared by Virginia Surveys, and dated June 13, 2025, and “Sketch Showing the Proposed Improvements on Lot 6, Block ‘C’, Section ‘1’, ‘East Payne Square’ in the City of Richmond, Va.,” prepared by Virginia Surveys, and dated December 12, 2025, hereinafter referred to, collectively, as “the Plans,” copies of which are attached to and made a part of this ordinance.

(b) The adoption of this ordinance shall constitute the issuance of a special use permit for the Property. The special use permit shall inure to the benefit of the owner or owners of the fee simple title to the Property as of the date on which this ordinance is adopted and their successors in fee simple title, all of which are hereinafter referred to as “the Owner.” The conditions contained in this ordinance shall be binding on the Owner.

§ 3. **Special Terms and Conditions.** This special use permit is conditioned on the following special terms and conditions:

(a) The Special Use of the Property shall be as up to one single-family detached dwelling and one single-family attached dwelling, substantially as shown on the Plans.

(b) All building materials, elevations, and site improvements shall be substantially as shown on the Plans.

(c) All mechanical equipment, including heating, ventilation, and air conditioning units, serving the Property shall be located or screened so as not to be visible from any adjoining public right-of- way.

(d) Prior to the issuance of any building permit for the Special Use, the establishment of no more than two residential lots, substantially as shown on the Plans, shall be accomplished by obtaining the necessary approvals from the City and recording the appropriate plats and deeds among the land records of the Clerk of the Circuit Court of the City of Richmond.

§ 4. **Supplemental Terms and Conditions.** This special use permit is conditioned on the following supplemental terms and conditions:

(a) All required final grading and drainage plans, together with all easements made necessary by such plans, must be approved by the Director of Public Utilities prior to the issuance of the building permit.

(b) Storm or surface water shall not be allowed to accumulate on the land. The Owner, at its sole cost and expense, shall provide and maintain at all times adequate facilities for the drainage of storm or surface water from the Property so as not to adversely affect or damage any other property or public streets and the use thereof.

(c) Facilities for the collection of refuse shall be provided in accordance with the requirements of the Director of Public Works. Such facilities shall be located or screened so as not to be visible from adjacent properties and public streets.

(d) Any encroachments existing, proposed on the Plans or contemplated in the future shall require separate authorization and shall be subject to the applicable provisions of the Code of the City of Richmond (2020), as amended, and all future amendments to such laws.

(e) In all other respects, the use of the Property shall be in accordance with the applicable underlying zoning regulations.

§ 5. **General Terms and Conditions.** This special use permit is conditioned on the following general terms and conditions:

(a) No permit implementing this special use permit shall be approved until satisfactory evidence has been presented to the Zoning Administrator that any delinquent real estate taxes applicable to the Property have been paid.

(b) The Owner shall be bound by, shall observe and shall comply with all other laws, ordinances, rules and regulations applicable to the Property, except as otherwise expressly provided in this ordinance.

(c) Words and phrases used in this ordinance shall be interpreted to have the meanings ascribed to them by section 30-1220 of the Code of the City of Richmond (2020), as amended, unless the context clearly indicates that a different meaning is intended.

(d) Notwithstanding any other provision of law, this special use permit is being approved due, in part, to the mitigating effects of each and every condition attached hereto; consequently, if any portion of this ordinance is determined to be invalid for any reason by a final,

non-appealable order of any Virginia or federal court of competent jurisdiction, the invalidity shall cause the entire ordinance to be void and of no further effect from the effective date of such order.

(e) The privileges granted by this ordinance may be revoked pursuant to the provisions of sections 30-1050.7 through 30-1050.11 of the Code of the City of Richmond (2020), as amended, and all future amendments to such laws. Failure to comply with the terms and conditions of this ordinance shall constitute a violation of section 30-1080 of the Code of the City of Richmond (2020), as amended, and all future amendments to such law, or any other applicable laws or regulations.

(f) When the privileges granted by this ordinance terminate and the special use permit granted hereby becomes null and void or when the Special Use of the Property as authorized by this ordinance is abandoned for a period of 733 consecutive calendar days, whether as a result of the Owner relinquishing this special use permit in a writing addressed to the Director of Planning and Development Review or otherwise, use of the Property shall be governed thereafter by the zoning regulations prescribed for the district in which the Property is then situated.

§ 6. **Implementation.** The Commissioner of Buildings is authorized to issue a building permit substantially in accordance with the Plans for the Special Use subject to the terms and conditions set forth in this ordinance. An application for the building permit shall be made within 1,096 calendar days following the date on which this ordinance becomes effective. If either the application for the building permit is not made within the time period stated in the previous sentence or the building permit terminates under any provision of the Virginia Statewide Building Code, this ordinance and the special use permit granted hereby shall terminate and become null and void.

§ 7. **Effective Date.** This ordinance shall be in force and effect upon adoption.

City of Richmond
Intracity Correspondence

O&R Transmittal

DATE: April 15, 2026
TO: The Honorable Members of City Council
THROUGH: The Honorable Dr. Danny Avula, Mayor (by request)
(This in no way reflects a recommendation on behalf of the Mayor)
THROUGH: Odie Donald II, Chief Administrative Officer
THROUGH: Sharon L. Ebert, DCAO for Economic Development and Planning
FROM: Kevin J. Vonck, Director of Planning & Development Review
RE: To authorize the special use of the property known as 902 N 28th Street for the purpose of up to one single-family detached dwelling and up to two single-family attached dwellings, upon certain terms and conditions.

ORD. OR RES. No. _____

PURPOSE: The applicant is requesting a Special Use Permit to allow the subdivision of the property into three lots that do not comply with the lot feature requirements of the R-6 Single-Family Attached zoning district. The proposal calls for the construction of a single-family detached dwelling on one parcel and a pair of single-family attached dwellings on two parcels. A Special Use Permit is therefore requested to authorize this proposal.

BACKGROUND: The vacant 6,227 square foot property is in Church Hill on the western side of N. 29th Street near its intersection with O Street to the south. The City’s Richmond 300 Master Plan designates a future land use for the subject property as Neighborhood Mixed-Use, which is described as “existing or new highly walkable urban neighborhoods that are predominantly residential.

Intensity: Buildings are generally two to four stories. Lot sizes generally range up to 5,000 to 20,000 square feet.

The current zoning for this property is R-6 Single-Family Attached Residential District. Adjacent properties to the north, south and east are also located within this district. Across the alley to the west are properties located in the R-63 Multifamily Urban Residential District.

COMMUNITY ENGAGEMENT: The Church Hill Central Civic Association has been notified. After introduction a sign shall be posted on the property and adjacent property owners shall receive notification by mail.

STRATEGIC INITIATIVES AND OTHER GOVERNMENTAL: Richmond 300 Master Plan

FISCAL IMPACT: \$400 application fee.

DESIRED EFFECTIVE DATE: Upon adoption

REQUESTED INTRODUCTION DATE: May 26, 2026

CITY COUNCIL PUBLIC HEARING DATE: June 22, 2026

REQUESTED AGENDA: Consent

RECOMMENDED COUNCIL COMMITTEE: Planning Commission June 16, 2026

AFFECTED AGENCIES: Office of Chief Administrative Officer
Law Department (for review of draft ordinance)

RELATIONSHIP TO EXISTING ORD. OR RES.: None

ATTACHMENTS: Draft Ordinance, Authorization from Property Owner, Applicant's Report, Plans, Survey

STAFF:

Alyson Oliver, Program and Operations Manager, Land Use Administration, 646-3709

David Watson, Planner, Land Use Administration (Room 511) 646-1036



CITY OF RICHMOND, VA
Department of Planning and Development Review
Land Use Administration Division
900 East Broad Street, City Hall - Room 511, Richmond, Virginia 23219

AUTHORIZATION FROM PROPERTY OWNER

TO BE COMPLETED BY THE APPLICANT
Applicant must complete ALL items

HOME/SITE ADDRESS: 530 E Main Street, Richmond VA 23219 APARTMENT NO/SUITE Suite 600

APPLICANT'S NAME: Alessandro Ragazzi EMAIL ADDRESS: [REDACTED]

BUSINESS NAME (IF APPLICABLE): Baker Development Resources

SUBJECT PROPERTY OR PROPERTIES: _____
902 n 28th

APPLICATION REQUESTED

- Plan of Development (New or Amendment)
- Wireless Plan of Development (New or Amendment)
- Special Use Permit (New or Amendment)
- Rezoning or Conditional Rezoning
- Certificate of Appropriateness (Conceptual, Administrative Approval, Final)
- Community Unit Plan (Final, Preliminary, and/or Amendment)
- Subdivision (Preliminary or Final Plat Correction or Extension)

TO BE COMPLETED BY THE AUTHORIZED OWNER
Owner must complete ALL items

Signing this affidavit acknowledges that you, as the owner or lessee of the property, authorize the above applicant to submit the above selected application/s on your behalf.

PROPERTY OWNER: COASTLINE CAPITAL PARTNERS LLC

PROPERTY OWNER ADDRESS: 2120 Staples Mill Rd #200

PROPERTY OWNER EMAIL ADDRESS: [REDACTED]

PROPERTY OWNER PHONE NUMBER: _____

Property Owner Signature: [Handwritten Signature]

The names, addresses, telephone numbers and signatures of all owners of the property are required. Please attach additional sheets as needed. If a legal representative signs for a property owner, please attach an executed power of attorney.

APPLICANT'S REPORT

December 15, 2025

*Special Use Permit Request
902 N 28th Street, Richmond, Virginia
Map Reference Number: E000-0477/004*

Submitted to:	City of Richmond Department of Planning and Development Review Land Use Administration 900 East Broad Street, Suite 511 Richmond, Virginia 23219
Submitted by:	Baker Development Resources 530 East Main Street, Suite 600 Richmond, Virginia 23219

Introduction

The property owner is requesting a special use permit (the "SUP") for 902 N 28th Street (the "Property"). The SUP would authorize the division of the parcel and the construction of one single-family detached and one single-family attached dwelling on the Property. While the single-family attached dwelling (to be attached to a similar dwelling at 902 2/3 N 28th Street) can be constructed by-right and the proposed single- and two-family uses are permitted by the underlying R-6 Single Family Residential zoning district, the lot width and area requirements cannot be met for the single-family detached dwelling, and therefore, the SUP is required.

Existing Conditions

SITE DESCRIPTION AND EXISTING LAND USE

The Property is located on the western line of N 28th Street between O and P Streets. The Property is referenced by the City Assessor as tax parcel E000-0477/004, is approximately 48 feet wide by 130 feet deep and contains approximately 6,227 square feet of lot area. The Property is vacant and access is provided by means of a north-south alley located to the rear of the Property.

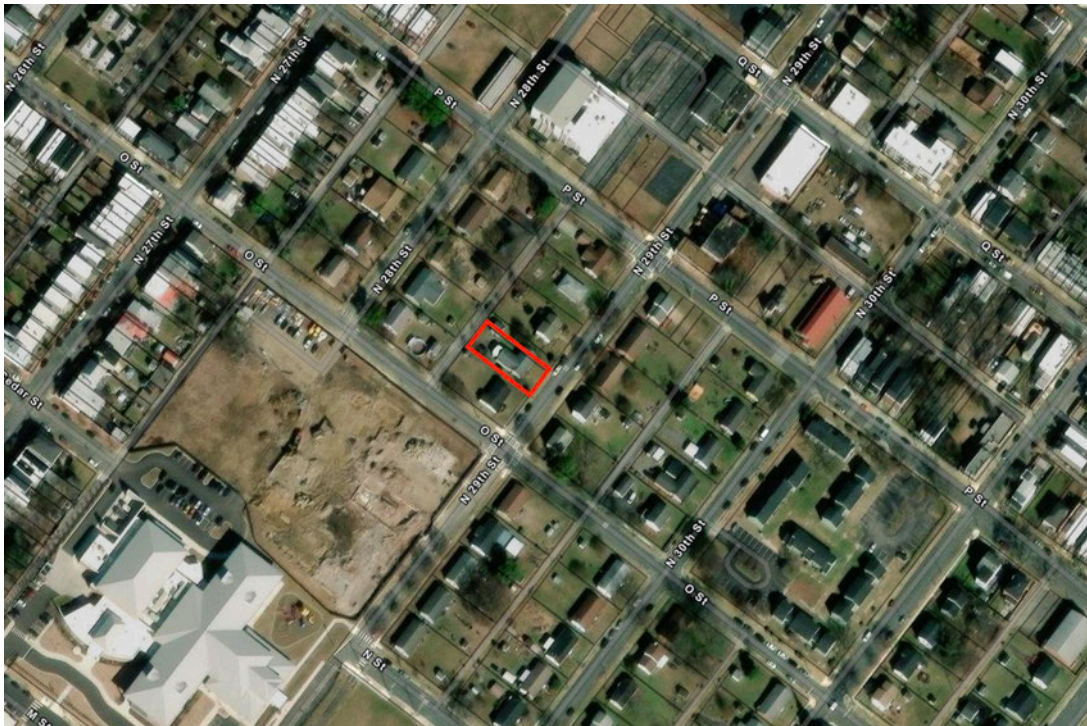

The properties in the area contain a range of dwellings. Immediately to the south lie primarily single-family dwellings while to the north, east, and west lie a wide range of properties and uses. Nearby properties contain, two-family residential, institutional, public open-space, and commercial uses. To the north, lie five attached dwellings fronting P street which were approved by SUP in 2022 while across P Street lies property owned by the City of Richmond Parks and

Recreation. The northwest corner of the block is occupied by the Fourth Baptist Church of Richmond. To the south lies Henry Marsh III Elementary School.

EXISTING ZONING

The Property and those in the immediate to the south and east are zoned R-6 Single-Family Attached Residential. To the west, across the alley, lies a R-63 Multifamily Urban Residential District. To the north, across P Street lies a B-2 Business District and to the South, across O Street lies a R-8 Urban Residential District.

TRANSPORTATION

Located 0.25 miles from the Property, less than a five-minute walk, is the 31st and O Street bus stop serving the 12 bus line which runs every 30 minutes and connects with the Pulse BRT providing connectivity throughout the City. The Property is also located less than a half mile from the 7 and 13 bus lines which run every thirty minutes.

MASTER PLAN DESIGNATION

The Richmond 300 Master Plan (the "Master Plan") suggests "Neighborhood Mixed-Use" for the Property. This land use category is described as "existing or new highly-walkable urban neighborhoods that are predominantly residential." The Master Plan suggests this future land use designation allow for a variety of housing types that are consistent with the scale, density, and design of what exists in the vicinity. Single-family dwellings are a primary use in the Neighborhood Mixed-Use designations which also encourages that developments reinforce a gridded street pattern to increase connectivity. Single-family dwellings are the contemplated primary use in the Residential future land use designation (p. 54).

In addition to the Property-specific guidance offered by the Vision and Core Concepts chapter, there are a number of other goals elsewhere within the Master Plan that support this request:

- Page 109 (Equitable Transportation Chapter), Objective 6.1 to "Increase the number of residents and jobs at Nodes and along enhanced transit corridors in a land development pattern that prioritizes multi-modal transportation options."
 - b. Develop housing at all income levels in and near Nodes and along major corridors (see strategies Goal 14).
- Page 136 (Diverse Economy Chapter), Objective 11.1 to "Increase the areas of appropriately zoned land near various transportation modes and housing to retain, create, and attract employers."
 - d. Encourage the development of a variety of quality housing types to house employees across the economic spectrum (see Goal 14).
- Page 159 (Thriving Environment Chapter) Objective 15.1 to "Reduce air pollution related to transportation."
 - a. Increase the number of Richmonders living in a development pattern that encourages density and reduces dependency on single-occupancy vehicles (see Goal 1, Goal 8, Goal 14).

- Page 86 (High-Quality Places Chapter), Objective 1.4, to “maintain and improve primarily residential areas by increasing their linkages to...corridors...and maintaining high-quality design standards”
- Page 100 (High Quality Places Chapter), Objective 4.1, to “create and preserve high-quality, distinctive, and well-designed neighborhoods and nodes throughout the City,” as the request introduces thoughtfully designed new construction in a manner not otherwise assured by-right.

Proposal

PROJECT SUMMARY

The proposed development includes the division of the parcel and the construction of one single-family detached dwelling on the southern portion of the parcel and a single-family attached dwelling on the northern portion of the parcel.

PURPOSE OF REQUEST

The subject Property is a legal lot of record and has a width of 47.9 feet along N 28th Street and contains approximately 6,227 square feet of lot area. The applicant is proposing to divide the Property into two lots and construct a single-family detached dwelling on the southern lot and a single-family attached dwelling on the northern lot. The proposed single-family attached dwelling on the northern lot will be attached to a similar dwelling at 902 2/3 N 28th Street and can be constructed by right as it will meet the underlying R-6 zoning requirements.

The underlying R-6 district permits both the single-family detached and attached dwelling uses. The northern parcel, abutting 902 2/3 N 28th and to contain the attached dwelling, will be 18 feet in width and contain around 2,110 square feet of lot area. The southern parcel, abutting 902 1/3 N 28th Street and containing the single-family detached dwelling, will be 18 feet in width and contain around 2,320 square feet of lot area. As the underlying R-6 zoning requires 50' of lot width and 5,000 square feet of lot area, a SUP is required.

The proposed lot areas are compatible with other lots in the vicinity and allow for the efficient use of the Property. This request would allow for the redevelopment of the Property in keeping with the original lot pattern and the character of the area while also providing for a mix of attached and detached dwellings.

In exchange for the SUP, this request will better ensure a high-quality market rate infill development. The overall project would be appropriately dense and efficient. It would be consistent with the use permitted by-right by the underlying zoning. At the same time, it would remain respectful to the historical lot pattern in the vicinity thereby remaining consistent with the predominant character of the area. Finally, the quality assurances conditioned through the SUP would guarantee a higher quality development than might otherwise be developed by right.

PROJECT DETAILS

When complete, each of the dwellings would be two stories in height and have been designed to be compatible with other dwelling forms found in the area. The single-family detached dwelling would have a gabled roof and full width front porch. It would contain three bedrooms and three bathrooms in roughly 2,320 square feet of finished floor area. The floor plans are modern and efficient with an open kitchen and living area on the first floor as well as an office at the rear of the dwelling which could also be converted into a bedroom for a growing family or for a family that needs a first-floor bedroom for a family member to age in place. The second floor includes a primary bedroom with ensuite bathroom along with two additional bedrooms. A full-width front porch would engage the street and provide usable outdoor living space.

The dwelling on the northern portion of the Property, to be attached to another by-right dwelling at 902 2/3 N 28th Street, would be of a similar layout with three bedrooms and three bathrooms as well as a first-floor office. The attached dwellings would contain 2,110 square feet of finished floor area and have a different façade than the detached dwelling to provide variety within the block.

All new dwellings would be clad in quality building materials including cementitious lap siding in order to ensure durability. The proposed dwelling's massing and architectural style is designed to be compatible with nearby dwellings and is consistent with other homes found in the neighborhood. Off-street parking space is provided for each dwelling.

Findings of Fact

The following are factors included in Section 17.11 of the Charter and Section 30-1050.1 of the Zoning Ordinance relative to the approval of special use permits by City Council. The proposed special use permit will not:

- ***Be detrimental to the safety, health, morals and general welfare of the community involved.***

The proposed special use permit for high-quality conversion of the existing dwelling will not impact the safety, health, morals and general welfare of the nearby neighborhoods.

- ***Tend to create congestion in streets, roads, alleys and other public ways and places in the area involved.***

The proposed special use permit will not result in significant traffic impacts to nearby residential neighborhoods. The negligible traffic generation related to the proposed dwellings and the proposed off-street parking will result in no congestion on streets, roads, alleys or any other public right of way.

- ***Create hazards from fire, panic or other dangers.***

The Property will be developed in a manner consistent with the requirements of the building code and in accordance with the requirements of Fire and Emergency Services. The City's codes applicable to this development are designed to eliminate such hazards.

- ***Tend to overcrowding of land and cause an undue concentration of population.***

The proposed special use permit is consistent with the historical lot pattern and density in the vicinity and will not tend to over crowd the land or create an undue concentration of population.

- ***Adversely affect or interfere with public or private schools, parks, playgrounds, water supplies, sewage disposal, transportation or other public requirements, conveniences and improvements.***

The special use permit would not adversely affect the above referenced City services. To the contrary, the proposal would provide positive fiscal (tax) benefits that would enhance the City's ability to provide these services to the proposed development.

- ***Interfere with adequate light and air.***

The light and air available to the subject and adjacent properties will not be affected. The proposed buildings are of compatible massing and spacing to the existing dwellings in the vicinity, which are in many cases attached. The proposed development will not interfere with the provision of adequate light and air to the adjacent buildings.

Summary

In summary we are enthusiastically seeking approval for the construction of the proposed single-family detached and single-family attached dwellings. The buildings have been thoughtfully designed in order to provide appropriate, high quality market rate infill development. The request offers compatibility with the City's Master Plan in terms of use. The request would contribute to the ongoing revitalization of the neighborhood, upgrading the Property while maintaining a desirable variation in housing style and density in the vicinity and providing for continued economic diversity in housing options within the neighborhood.

The proposed development would provide for respectful development that is consistent with the objectives of the Master Plan. It would respectfully encourage a pedestrian friendly traditional urban streetscape in the block. The proposed design is historically appropriate and would contribute to the vibrancy of the block with a street-oriented front porch. The appropriate urban form would give the property the much-desired traditional neighborhood design which is appropriate to this area of the City. Finally, the quality assurances conditioned through the SUP would guarantee a higher quality development than might otherwise be developed by right.

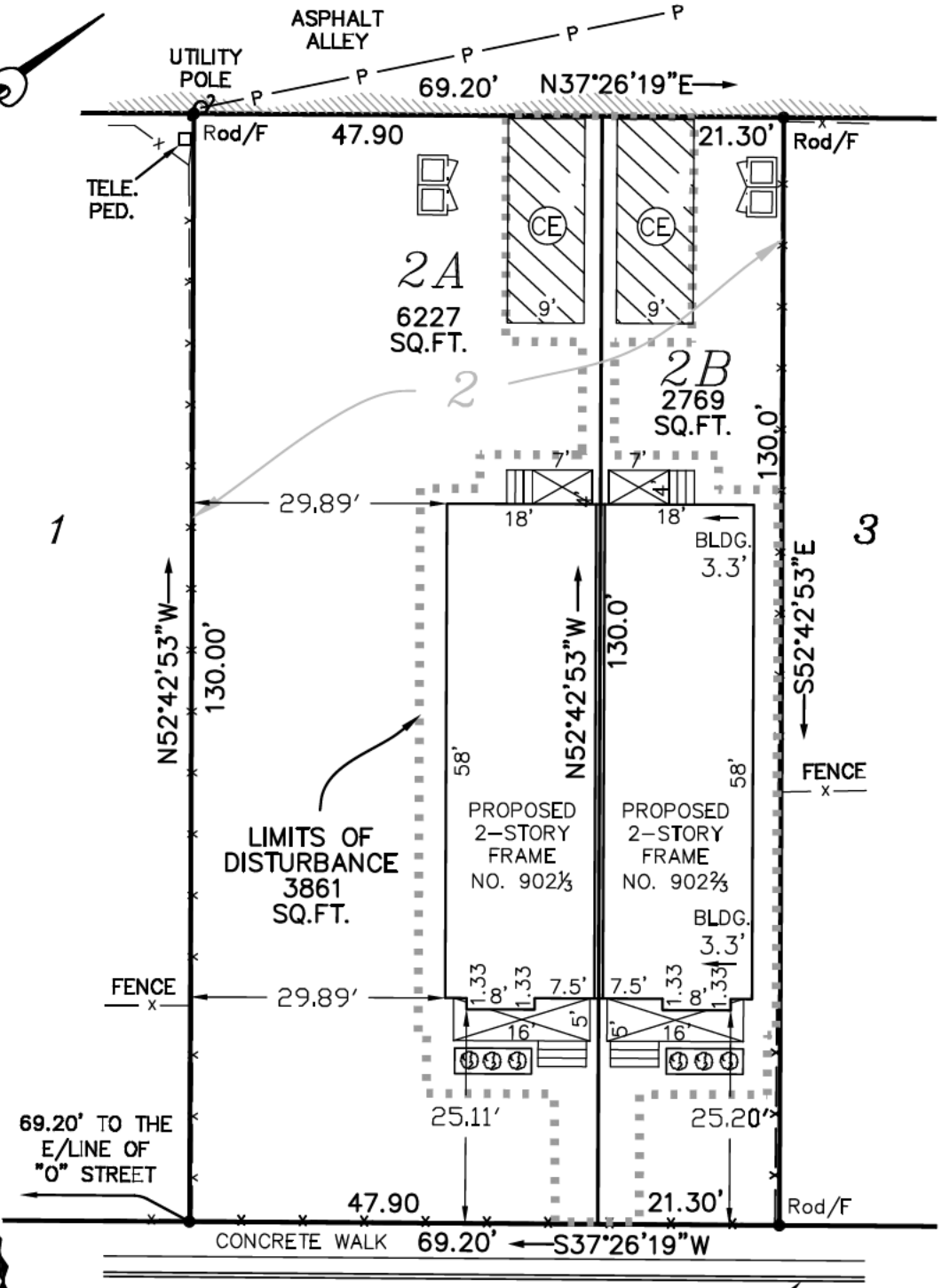
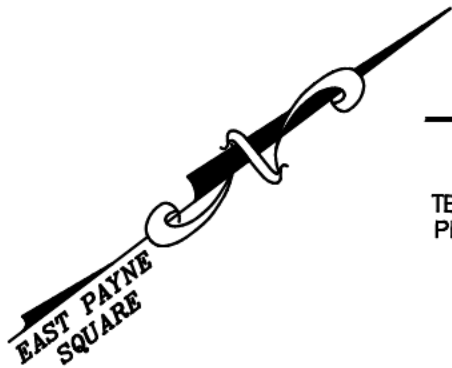

- MULCH BED WITH LANDSCAPING
- SUPER CANS WITH SCREENING < 5' TALL
- CONSTRUCTION ENTRANCE



Virginia Surveys
 P.O. BOX 118
 CHESTERFIELD, VA 23832
 (804) 748-9481
 COPYRIGHT © VIRGINIA SURVEYS
 All rights reserved.

N 28TH ST
 50' R/W

SKETCH SHOWING THE PROPOSED
 LOT SPLIT & IMPROVEMENTS
 ON LOT 2, BLOCK "C", SECTION "1",
 "EAST PAYNE SQUARE"
 IN THE CITY OF RICHMOND, VA.

DATE: 6-13-2025
 CERTIFIED BY JEFFREY K. FLOYD
 VIRGINIA CERTIFICATE NO. 001905
 SCALE: 1"=20'
 JOB NO. 250416765

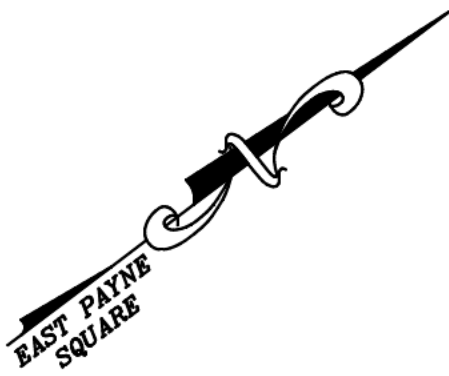

- MULCH BED WITH LANDSCAPING
- SUPER CANS WITH SCREENING < 5' TALL
- CONSTRUCTION ENTRANCE

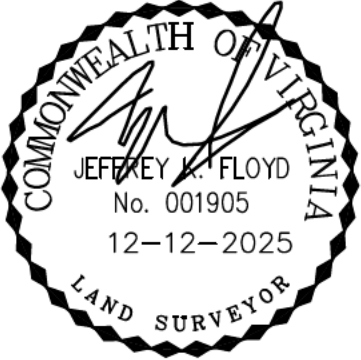
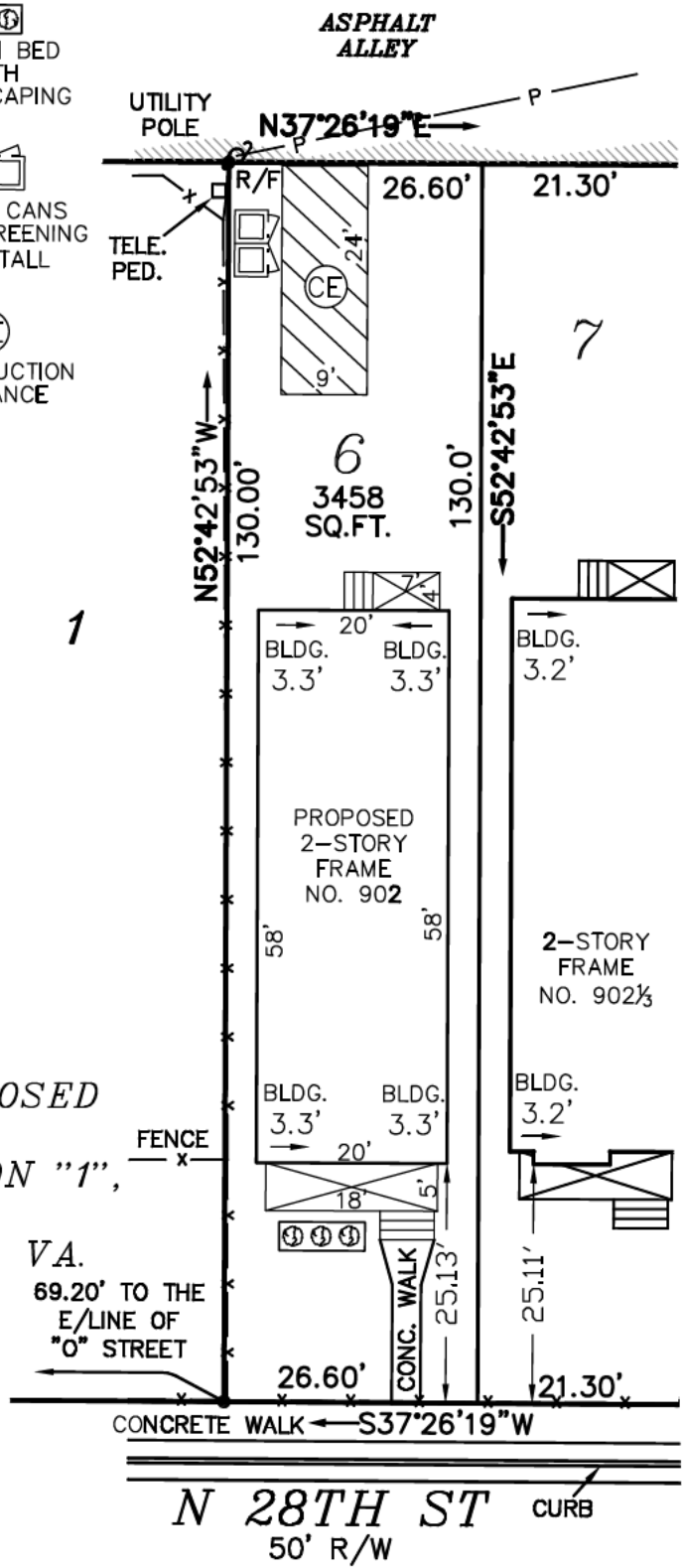

SKETCH SHOWING THE PROPOSED IMPROVEMENTS ON LOT 6, BLOCK "C", SECTION "1", "EAST PAYNE SQUARE" IN THE CITY OF RICHMOND, VA.



Virginia Surveys
 P.O. BOX 118
 CHESTERFIELD, VA 23832
 (804) 748-9481
 COPYRIGHT © VIRGINIA SURVEYS
 All rights reserved.

DATE: 12-12-2025
 CERTIFIED BY JEFFREY K. FLOYD
 VIRGINIA CERTIFICATE NO. 001905
 SCALE: 1"=20'
 JOB NO. 250416765

GENERAL NOTES AND DESIGN CRITERIA

FOLLOW LATEST BUILDING CODE: IRC & VRC 2021

DESIGN LOADS (MIN.):

FLOOR:	40 PSF LIVE LOAD	CEILING:	20 PSF LIVE LOAD
	10 PSF DEAD LOAD		10 PSF DEAD LOAD
ROOF:	20 PSF LIVE LOAD	ROOF DESIGN WIND SPEED:	115 MPH
	10 PSF DEAD LOAD	(TRUSSES: TC AND BC DEAD LOAD OF 10 PSF EACH)	
SLEEPING AREAS:	30 PSF LIVE LOAD	SEISMIC CATEGORY	B

SOIL BEARING CAPACITY: ASSUMED 2000 PSF
LIVE LOADS, DEAD LOADS, WIND LOADS, SNOW LOADS, LATERAL LOADS, SEISMIC ZONING, AND ANY OTHER SPECIALTY LOADING WILL NEED TO BE CONFIRMED BEFORE CONSTRUCTION AND DEALT WITH ACCORDINGLY.

FRAMING MEMBERS:
UNLESS OTHERWISE NOTED, ALL FRAMING LUMBER TO BE #2 OR BETTER.
CONTRACTOR TO CONFIRM THE SIZE, SPACING, AND SPECIES OF ALL FRAMING AND STRUCTURAL MEMBERS.
ALL EXTERIOR WALLS AND CEILING/ROOF ARE TO BE INSULATED BY CODE.
ENGINEERED WOOD PRODUCTS TO BE ENGINEERED BY MANUFACTURER/SUPPLIER.
TRUSSES TO BE ENGINEERING BY TRUSS MANUFACTURER/SUPPLIER.
FOLLOW BRACING GUIDELINES SUBMITTED BY TRUSS MANUFACTURER.

CONCRETE AND FOUNDATIONS:
ALL SLABS ON GRADE SHALL BE 3500 PSI MIN.
ALL SLABS ON GRADE SHALL BEAR ON 4" COMPACTED GRANULAR FILL WITH 6X6 MIN. WELDED WIRE MESH (WWM).
INTERIOR SLABS SHALL HAVE A 10 MIL. MIN. POLYETHYLENE VAPOR BARRIER UNDERNEATH.
PROVIDE PROPER EXPANSION AND CONTROL JOINTS.
PROVIDE REINFORCING WHERE NEEDED ACCORDING TO LOCAL CODES, REQUIREMENTS, AND DESIGN.
FOUNDATION WALLS ARE NOT TO BE BACKFILLED UNTIL STRUCTURAL FRAMING IS COMPLETE.
VERIFY DEPTH OF FOOTINGS TO MAKE SURE IT IS BELOW FROST LINE.

STEEL:
ALL STRUCTURAL STEEL TO COMPLY WITH ASTM STANDARDS AND SPECIFICATIONS.

SAFETY GLAZING IS REQUIRED PER CODE INCLUDING BUT NOT LIMITED TO THE FOLLOWING: GLAZING IN SWINGING DOORS EXCEPT JALOUSIES, GLAZING IN FIXED AND SLIDING PANEL DOORS, GLAZING IN STORM DOORS, GLAZING IN ALL UN-FRAMED DOORS, GLAZING IN DOORS AND ENCLOSURES FOR BATHTUBS AND SHOWERS WHOSE BOTTOM EXPOSED EDGE IS LESS THAN 60" ABOVE THE WALKING/STANDING SURFACE, GLAZING IN PANELS ADJACENT TO AND WITHIN 24" OF THE EDGE OF A SWINGING DOOR, GLAZING LESS THAN 18" ABOVE THE FLOOR, GLAZING IN RAILINGS, GLAZING IN FENCES OR WALLS ENCLOSING SWIMMING POOLS-HOT TUBS-SPAS, GLAZING IN STAIRWAYS-LANDINGS-RAMPS, GLAZING WITHIN 60" OF THE BOTTOM TREAD OF A STAIRWAY. PER CODE, A MIN. NET CLEAR OPENING OF 5.7 SQ. FT. (24" HIGH X 20" WIDE) AND A MAX SILL HEIGHT OF 44" ABOVE FINISH FLOOR IS REQUIRED FOR ALL EMERGENCY ESCAPE AND RESCUE WINDOWS. THE WINDOW DIMENSIONS SHOWN ON THIS PLAN MAY VARY DEPENDING ON THE CHOSEN MANUFACTURER. CONTRACTOR MUST VERIFY THE CHOSEN WINDOWS MEET THE EGRESS REQUIREMENTS. PROVIDE WINDOW WELLS AS REQUIRED. COMPLIANCE TO EMERGENCY EGRESS IS REQUIRED.
COMPLIANCE TO SECTION R313 FOR SMOKE & CO2 DETECTORS IS REQUIRED. SMOKE DETECTORS SHALL BE LISTED IN ACCORDANCE WITH CURRENT UL AND HARDWIRED, INTERCONNECTED, AND ARC FAULT PROTECTED WITH A BATTERY BACKUP.
GARAGE WALLS ARE TO BE COVERED PER CODE. TYPICAL GARAGE WALLS AND ATTIC SPACE/CEILING ASSEMBLIES ARE TO BE COVERED WITH A MIN. 1/2" GYPSUM WALLBOARD. GARAGE RESIDENCE SEPARATION WALLS AND FLOOR/CEILING ASSEMBLIES ARE TO BE COVERED WITH A MIN. 5/8" TYPE "X" GYPSUM WALLBOARD. DOORS SEPARATING THE GARAGE AND RESIDENCE ARE TO BE MIN. 20-MINUTE FIRE RATED OR SOLID WOOD, NOT LESS THAN 1-3/8" THICK.

DESIGNER: NICK MEDLIN
POSITION: OWNER / OPERATOR
179 MURIEL DR. HEATHSVILLE VA 22473

902 N 28TH ST. (DETACHED DWELLING)

LOCATION:
RICHMOND, VA

DRAWING INDEX

COVER PAGE	C1.0
FLOOR PLANS	A1.1
ELEVATIONS	A2.1
FOUNDATION	A3.1
FRAMING PLANS	A3.2
WALL BRACING	A4.1
SECTIONS / DETAILS	D1.0

BUILDING INFORMATION

1ST FL. HEATED S.F.	1160
2ND FL. HEATED S.F.	1160

COMPLIANCE IS REQUIRED FOR EXIT DOOR STAIRS, RAMPS, AND LANDINGS. THERE SHALL BE A FLOOR OR LANDING ON EACH SIDE OF EACH EXT. DOOR EXCEPT WHERE A STAIRWAY OF TWO OR FEWER RISERS IS LOCATED. THE WIDTH OF EACH LANDING SHALL NOT BE LESS THAN THE WIDTH OF THE DOOR SERVED. EVERY LANDING SHALL HAVE A MIN. OF 36" IN DIRECTION OF TRAVEL.

COMPLIANCE IS REQUIRED FOR HANDRAILS (TYPE 1) AND GUARDRAILS. ALL INT. AND EXT. RAILINGS ARE TO BE A CONTINUOUS AND MIN. 36" IN HEIGHT, BE ABLE TO WITHSTAND 200 LBS OF FORCE, AND NOT ALLOW A SPHERE GREATER THAN 4' IN DIAMETER TO PASS THROUGH. GUARDRAILS ARE TO BE 36" HIGH WITH MAX SPACING BETWEEN PICKETS OF LESS THAN 4". HANDRAILS ARE TO BE BETWEEN 34"-36" HIGH WITH MAX SPACING BETWEEN PICKETS NOT MORE THAN 4".

DRAFT-STOPPING IS REQUIRED PER CODE. WHEN THERE IS USABLE SPACE BOTH ABOVE AND BELOW THE CONCEALED SPACE OF A FLOOR/CEILING ASSEMBLY, DRAFT-STOPS SHALL BE INSTALLED SO THAT THE CONCEALED SPACE DOES NOT EXCEED 1000 SF. DRAFT-STOPPING SHALL BE INSTALLED SO AS TO DIVIDE THE SPACE EVENLY. DRAFT-STOPPING IS REQUIRED IN SUSPENDED CEILINGS UNDER THE FLOOR SYSTEM AND WHEN THE FLOOR FRAMING IS CONSTRUCTED OF TRUSS TYPE OPEN WEB OR PERFORATED MEMBERS.

FIRE-BLOCKING IS REQUIRED. FIRE BLOCKING SHALL BE PROVIDED TO CUT OFF ALL CONCEALED DRAFT OPENINGS (VERTICAL & HORIZONTAL) AND FORM AN EFFECTIVE FIRE BARRIER BETWEEN STORIES.

902 N 28TH ST.

RIVER MILL DEVELOPMENT
RIVERMILLDEVELOPMENT@GMAIL.COM
PHONE: (434) 774-4535

REVISION NOTES

DATE	START

SCALE:
N/A

DATE:
6-16-2025

SHEET:
C1.0



NOTE: DOOR & WINDOW GLAZING SHALL HAVE A MAX U-FACTOR OF 0.32
 NOTE: DOOR & WINDOW GLAZING SHALL HAVE A MAX SOLAR HEAT GAIN COEFFICIENT (SHGC) OF 0.4

CO + SMOKE DETECTOR (CO)
 SMOKE DETECTOR (SD)

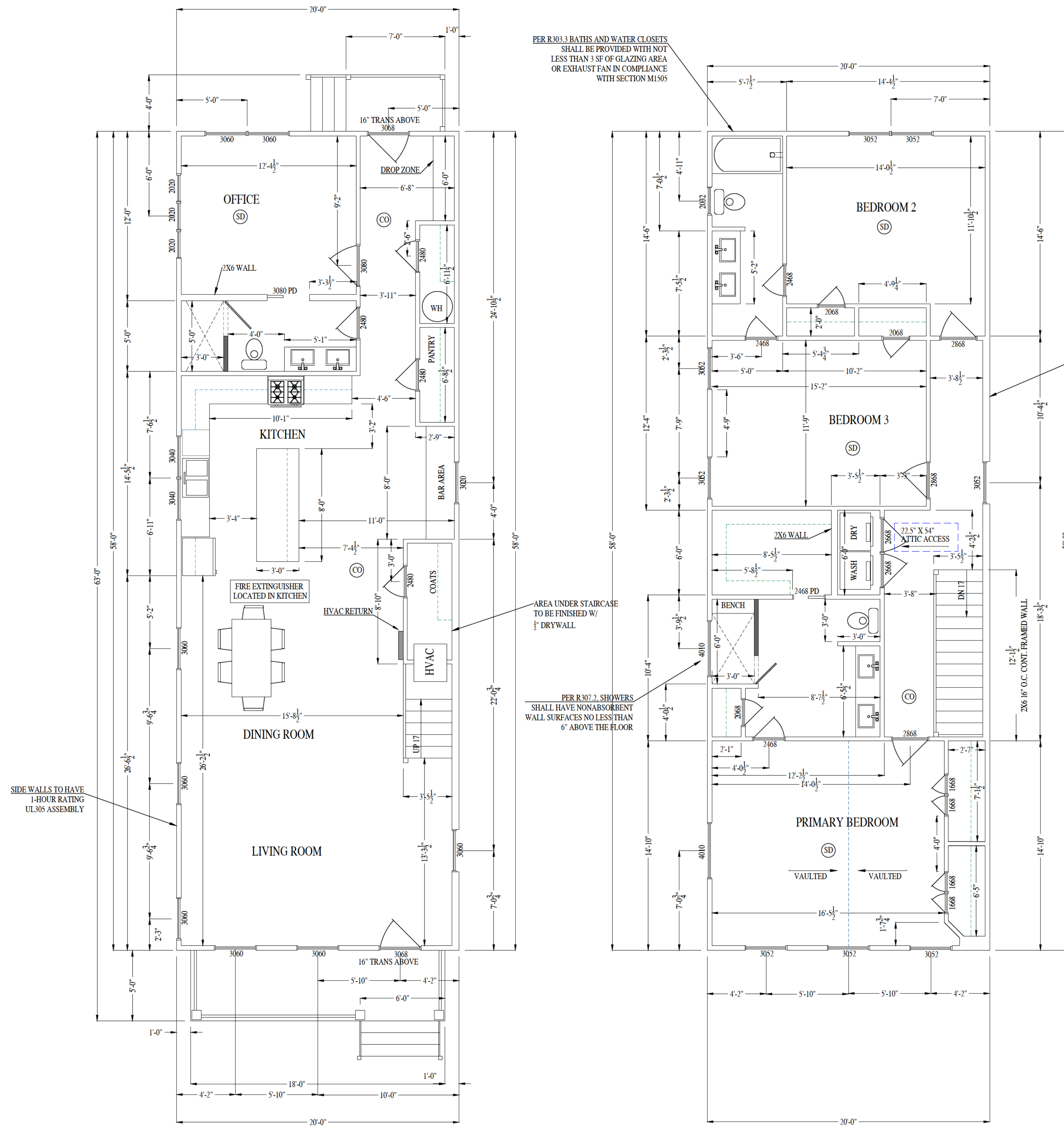

FIRST FLOOR PLAN

1160 S.F.

SECOND FLOOR PLAN

1160 S.F.

902 N 28TH ST.

RIVER MILL DEVELOPMENT

RIVERMILLDEVELOPMENT@GMAIL.COM
 PHONE: (434) 774-4533

REVISION NOTES

DATE	START

SCALE:
 1/4" = 1'-0"

DATE:
 6-16-2025

SHEET:
 A1.1



ALL SINGLE WINDOW AND DOOR HEADERS
TO BE (2) 2X8 W/ 1 JACK + 1 KING MIN. UNLESS OTHERWISE NOTED.

NOTE: REFER TO TRUSS MANUFACTURER'S LAYOUTS AND PROFILES FOR 2ND FLOOR AND ROOF FRAMING SPECIFICS AND ACCURACY

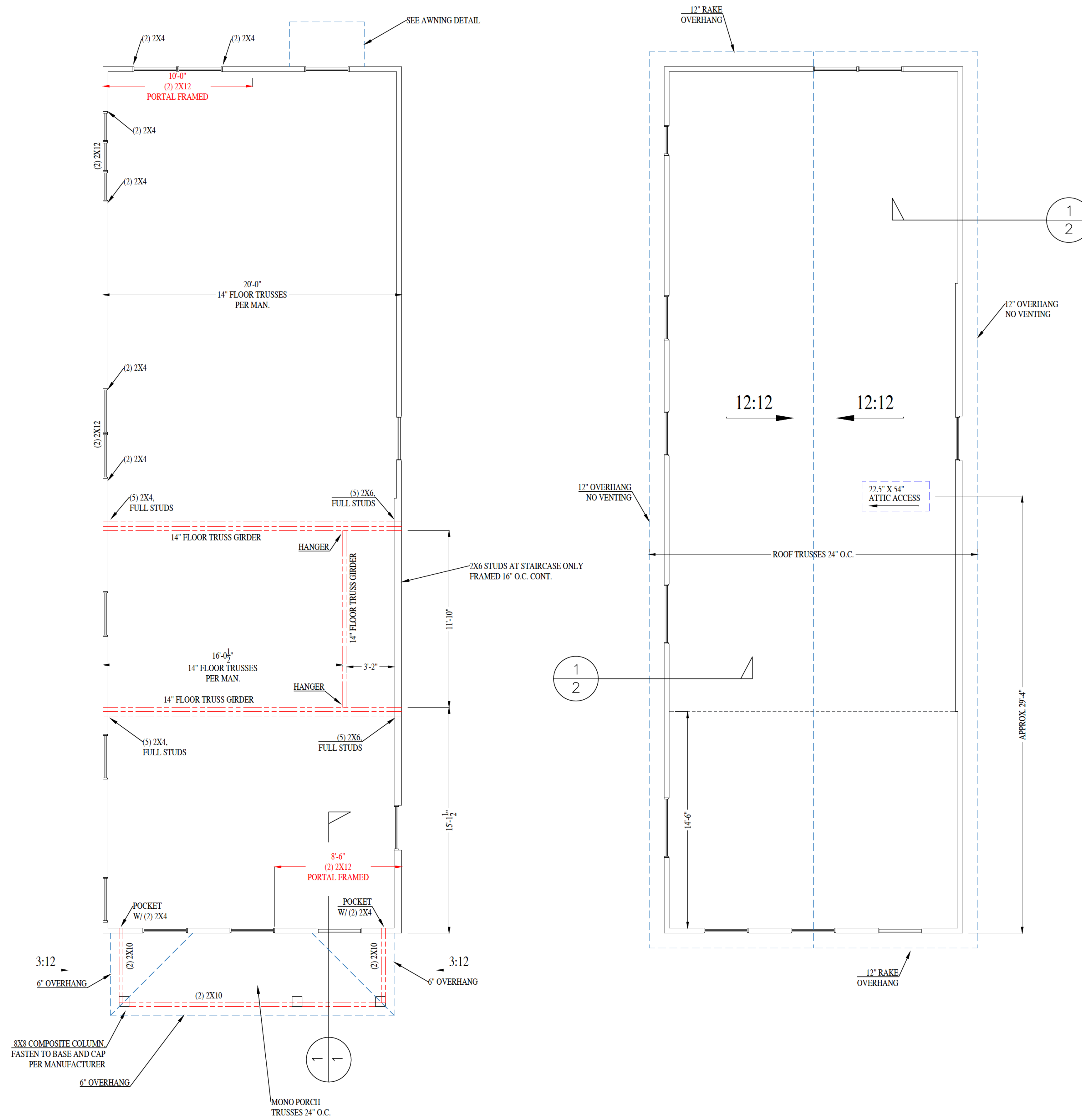

SECOND FLOOR FRAMING

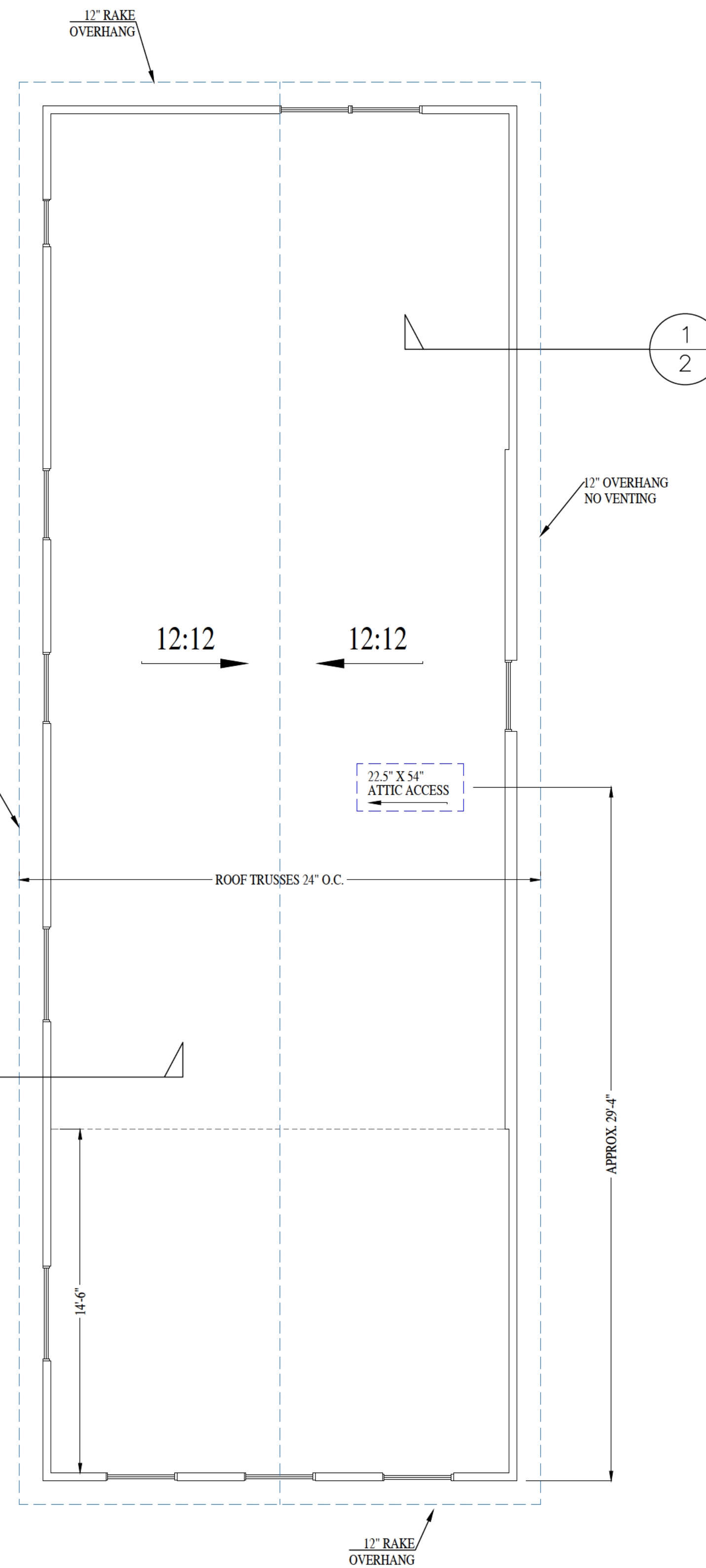

ROOF PLAN

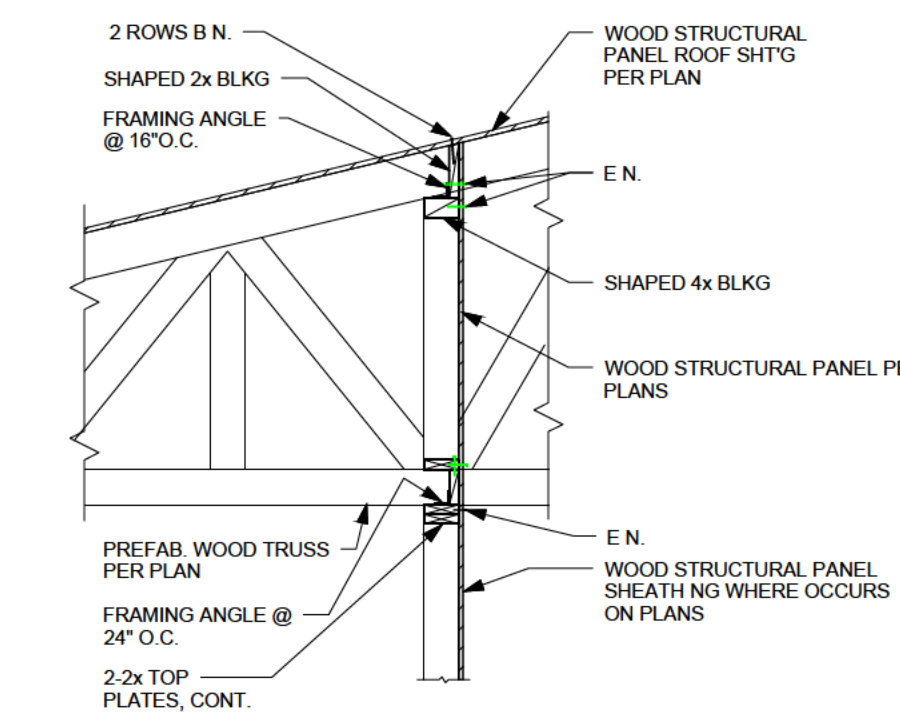
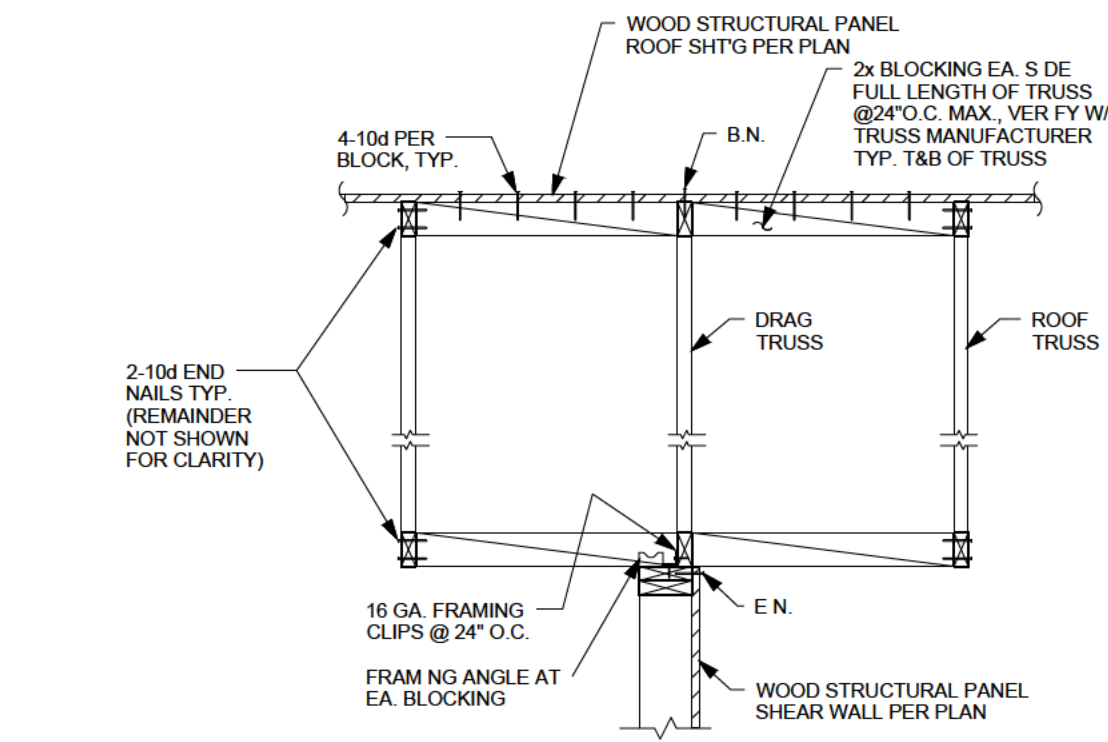
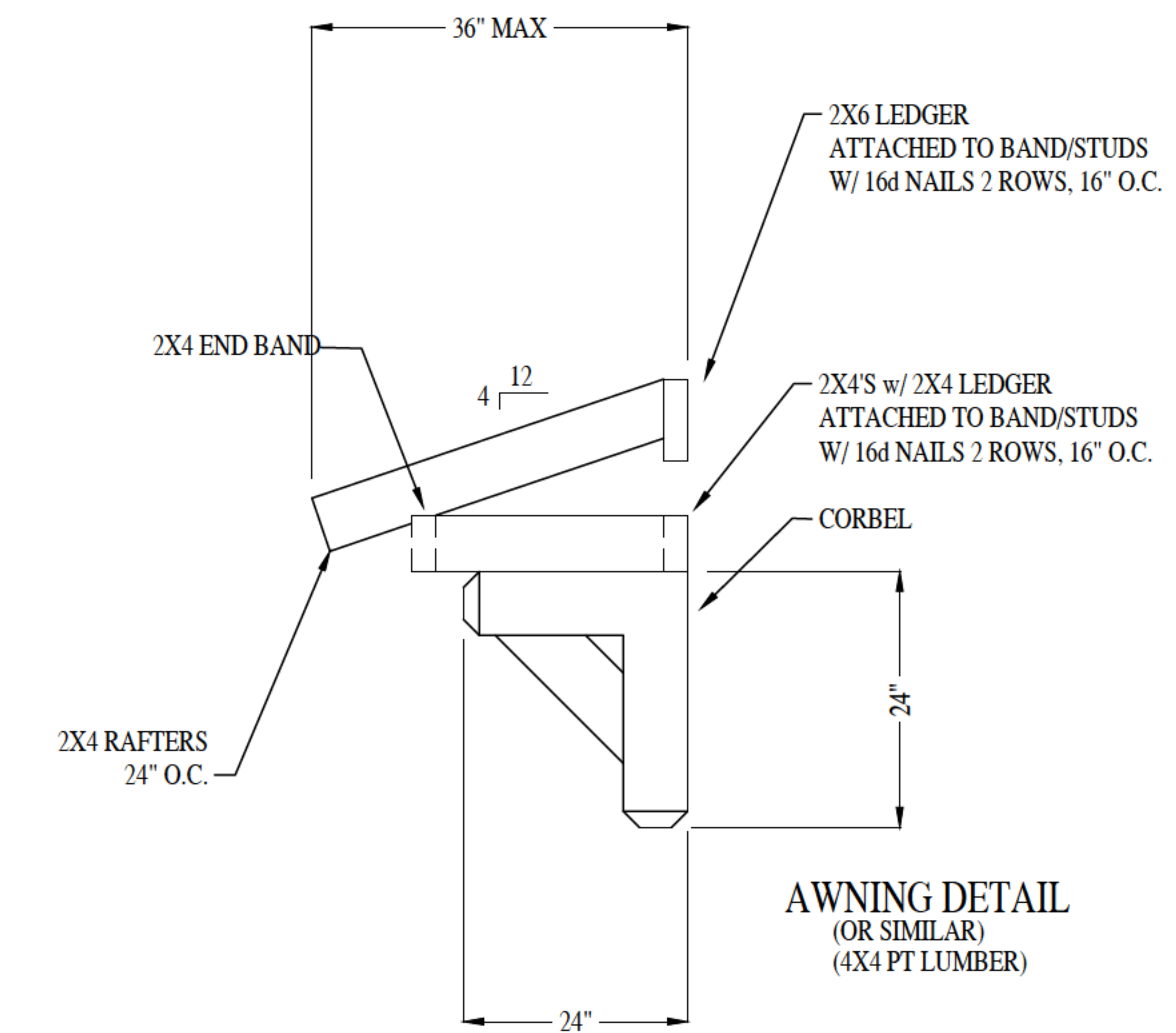

UPPER ROOF VENTING:
1160 S.F. TOTAL - 1/150 REQUIRED
1114 S. INCHES REQUIRED
GABLE VENTING + RIDGE VENTING

902 N 28TH ST.

RIVER MILL DEVELOPMENT
RIVERMILLDEVELOPMENT@GMAIL.COM
PHONE: (434) 774-4535

REVISION NOTES

DATE	START

SCALE:
1/4" = 1'-0"

DATE:
6-16-2025

SHEET:
A3.2



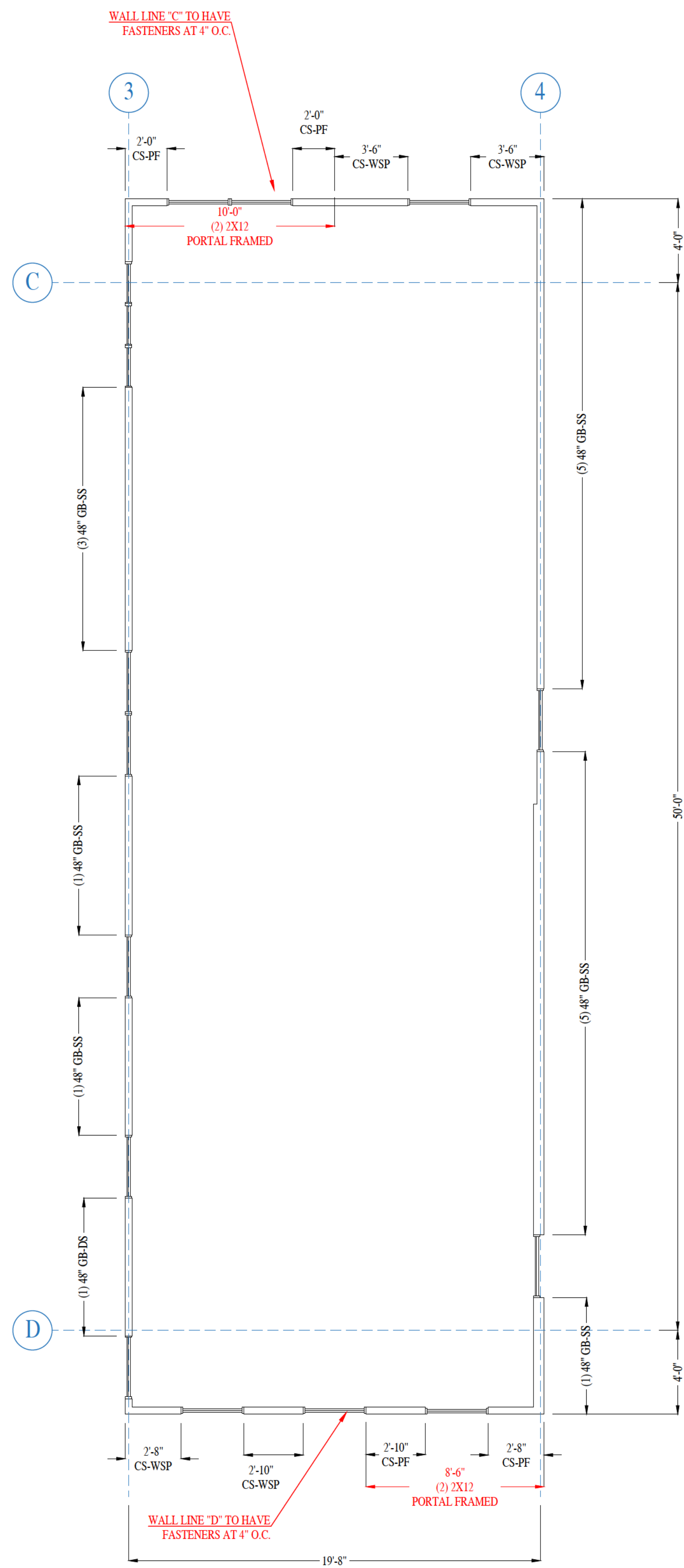

FIRST FL. WALL BRACING

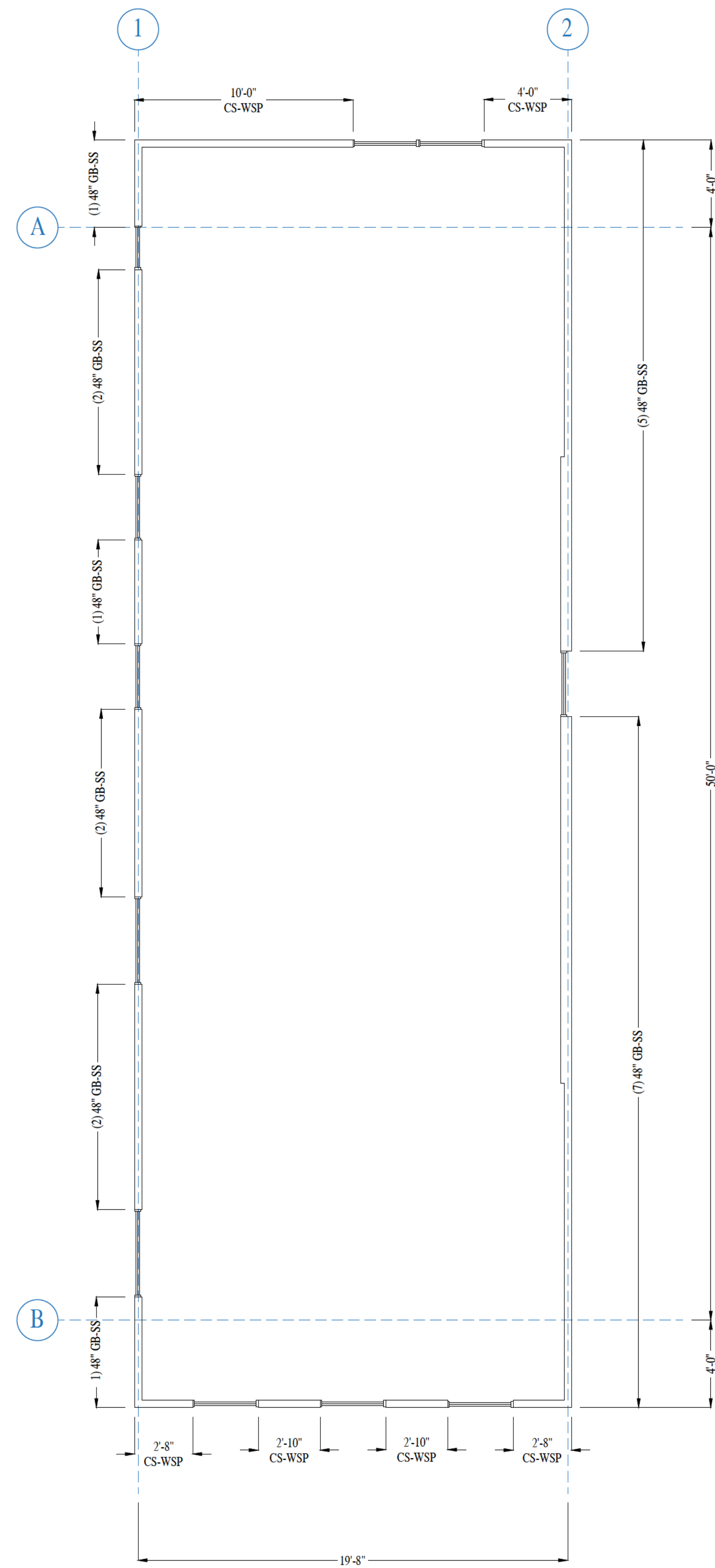

SECOND FL. WALL BRACING

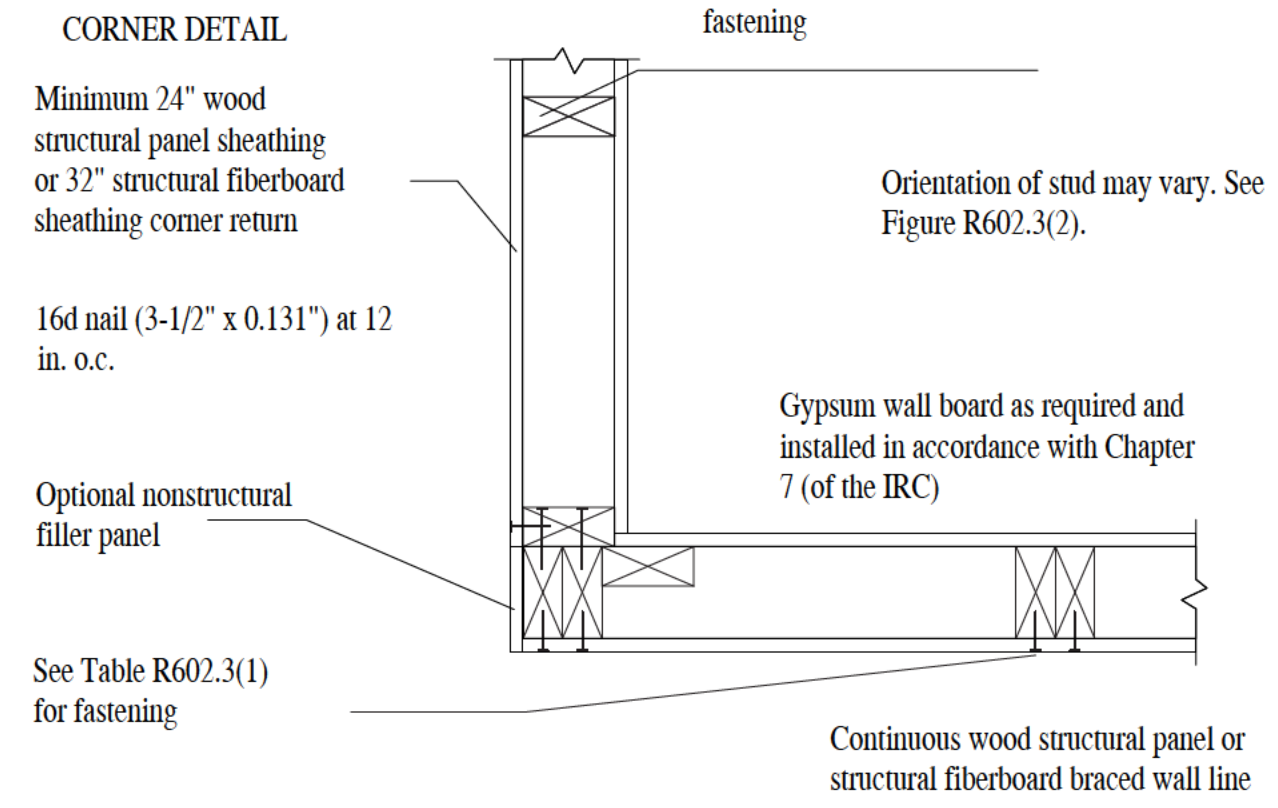

CS-PF = 1.5 X ACTUAL

Ultimate Wind Speed (mph)		115		115		115		115		115		115			
BWL Designation		1		2		A		B		3		4			
No. of Floors above BWL		0		0		0		0		1		1			
BWP Method		GB		GB		CS-WSP		CS-WSP		GB		GB			
Average BWL Spacing (ft)		20		20		50		50		20		20			
Tabular Requirement (ft)		6.50		6.50		7.50		7.50		12.50		12.50			
Adjustments	Exposure	B	1.00	B	1.00	B	1.00	B	1.00	B	1.00	B	1.00		
	Eave-to-Ridge Ht. (ft)	11.50	1.09	11.50	1.09	11.50	1.09	11.50	1.09	11.50	1.05	11.50	1.05		
	Max. Wall Ht. (ft)	9.00	0.95	9.00	0.95	9.00	0.95	9.00	0.95	10.00	1.00	10.00	1.00		
	No. of BWLs	2	1.00	2	1.00	2	1.00	2	1.00	2	1.00	2	1.00		
	Omit Interior Finish?	No	1.00	No	1.00	No	1.00	No	1.00	No	1.00	No	1.00		
	Added Hold-downs?	No	1.00	No	1.00	No	1.00	No	1.00	No	1.00	No	1.00		
	Joints Blocked?	Yes	1.00	Yes	1.00	Yes	1.00	Yes	1.00	Yes	1.00	Yes	1.00		
Fasteners @ 4" o.c.?	No	1.00	No	1.00	No	1.00	No	1.00	No	1.00	Yes	0.83	Yes	0.83	
Required BWP Length (ft)		6.73		6.73		7.77		7.77		13.06		13.06			
Actual BWPs	Contributing Length (ft)	BWP	Method	Length	Method	Length	Method	Length	Method	Length	Method	Length	Method	Length	
	1	GB (ss)	2.00	GB (ss)	10.00	CS-WSP	10.00	CS-WSP	2.67	GB (ss)	6.00	GB (ss)	10.00	CS-PF	3.00
	2	GB (ss)	4.00	GB (ss)	14.00	CS-WSP	4.00	CS-WSP	2.83	GB (ss)	2.00	GB (ss)	10.00	CS-PF	3.00
	3	GB (ss)	2.00					CS-WSP	2.83	GB (ss)	2.00	GB (ss)	2.00	CS-WSP	3.50
	4	GB (ss)	4.00					CS-WSP	2.67	GB (ss)	4.00			CS-WSP	3.50
	5	GB (ss)	4.00											CS-PF	4.00
	6	GB (ss)	2.00												
Actual BWP Length (ft)		18.00		24.00		14.00		11.00		14.00		22.00		13.00	
Actual \leq Required?		PASS		PASS		PASS		PASS		PASS		PASS		PASS	
BWPs \leq 20' Apart?		Yes		Yes		Yes		Yes		Yes		Yes		Yes	
\geq 2 Panels in BWL?		Yes		Yes		Yes		Yes		Yes		Yes		Yes	
BWP 10' from Ends?		Yes		Yes		Yes		Yes		Yes		Yes		Yes	
Continuous Sheathing End Conditions		End 1	End 2	End 1	End 2	End 1	End 2	End 1	End 2	End 1	End 2	End 1	End 2	End 1	End 2
BWL Compliance		PASS		PASS		PASS		PASS		PASS		PASS		PASS	

902 N 28TH ST.
RIVER MILL DEVELOPMENT
 RIVERMILLDEVELOPMENT@GMAIL.COM
 PHONE: (434) 774-4535

REVISION NOTES

DATE	START

SCALE:
 1/4" = 1'-0"

DATE:
 6-16-2025

SHEET:
 A4.1

